

# MB



Hoogeindsestraat 5  
NL - 5447 PD Rijkevoort  
Nederland  
T : +31 (0) 485 - 371318  
F : +31 (0) 485 - 371918  
info@pompentechniek.nl  
www.pompentechniek.nl

## GENERALITA' / FEATURES

Elettropompe centrifughe bigirante in ghisa adatte alla pressurizzazione di impianti domestici, piccola irrigazione, movimentazione di liquidi non aggressivi ad uso civile ed industriale.

*2 impellers centrifugal pumps made of cast-iron, suitable to boost domestic systems, small irrigation, pumping of non-aggressive liquids for civil and industrial use.*

## MATERIALI / MATERIALS

- Corpo pompa e supporto: ghisa
- Albero: acciaio inox AISI 303
- Giranti e diffusore: Noryl®
- Tenuta meccanica in ceramica grafite

- *Pump body and bracket: cast iron*
- *Shaft: stainless steel AISI 303*
- *Impellers and diffuser: Noryl®*
- *Ceramic graphite mechanical seal*

## MOTORE / MOTOR

- Motore chiuso autoventilato
- Grado di protezione: IP44
- Isolamento classe F
- Alimentazione monofase 230V-50Hz con protezione termica incorporata e condensatore perennemente inserito
- Alimentazione trifase 230/400V-50Hz con protezione a cura dell'utilizzatore

- *Closed self ventilated motor*
- *Protection: IP44*
- *Insulation class F*
- *Single-phase feeding 230V-50Hz with built-in thermal protection and capacitor permanently connected*
- *Three-phase feeding 230/400V-50Hz, with protection at user's care*

## LIMITI DI IMPIEGO / OPERATING CONDITIONS

- Pressione max: 8 ATE
- Temperatura acqua max: 50°C
- *Max. pressure: 8 bar*
- *Water temperature max: 50°C*

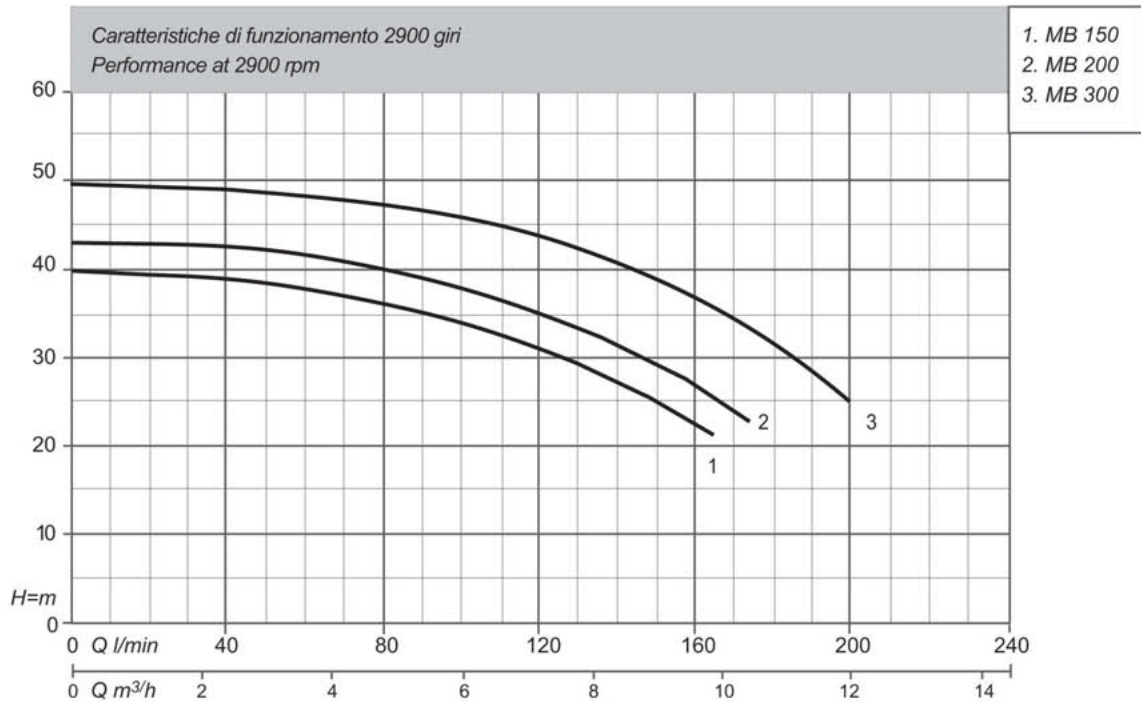

**CARATTERISTICHE TECNICHE 2900 GIRI / TECHNICAL PERFORMANCE AT 2900 RPM**

Modello Model		Pot. nominale Nominal power		AMPERE		Q=Portata - capacity										
Monofase Single-phase 230V 50Hz	Trifase Three-phase 230/400V 50Hz	Hp P2	kW P2	Monofase Single-phase 230V	Trifase Three-phase 400V	m <sup>3</sup> /h	0,9	1,8	2,7	3,6	4,8	6	7,2	9	10,8	12
						l/min	15	30	45	60	80	100	120	150	180	200
MB 150	MBt 150	1,5	1,1	7,7	2,9	39,5	39	38,5	37,5	36,5	34	31	25			
MB 200	MBt 200	2,2	1,65	9,5	3,6	43	42,5	42	41,5	40	37,5	35	29			
	MBt 300	3,0	2,2		4,8	49	48	47,5	47,1	46,5	46	44	38,5	31,5	25	

Prevalenza manometrica totale in m C.A.  
Total head in meters w.c.

Caratteristiche di funzionamento per servizio continuo, con altezza di aspirazione fino a 7 m e  $\gamma=1 \text{ Kg/dm}^3$ . Per aspirazione oltre 4 m installare un tubo aspirante con diametro interno maggiore del diametro della bocca aspirante.  
Performance specified refer to continuous operation, with a manometric suction lift of 97 m and  $\gamma=1 \text{ Kg/dm}^3$ . For suction over 4 m install a sucking pipe with internal diameter larger than the suction connection.

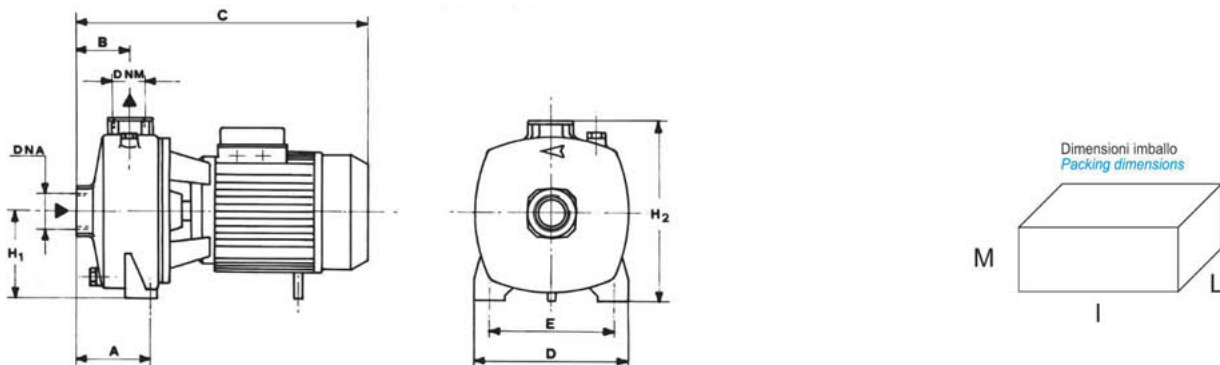

MODELLO POMPA PUMP'S MODEL	DIMENSIONI POMPA mm PUMP'S DIMENSIONS mm									DIMENSIONI IMBALLO mm PACKING DIMENSIONS mm			PESO WEIGHT
	A	B	C	D	E	H1	H2	DNA	DNM	I	L	M	kg
MB 150	108	73	385	205	165	115	242	1"1/2G	1"1/4G	405	225	295	21,2
MB 200	108	73	385	205	165	115	242	1"1/2G	1"1/4G	405	225	295	21,7
MB 300	108	73	385	205	165	115	242	1"1/2G	1"1/4G	405	225	295	21,7