

Immersion Pumps (S)TH11

Closed impellers



Hoogeindestraat 5
NL - 5447 PD Rijkevoort
Nederland
T : +31 (0) 485 - 371318
F : +31 (0) 485 - 371918



STH1102...1115

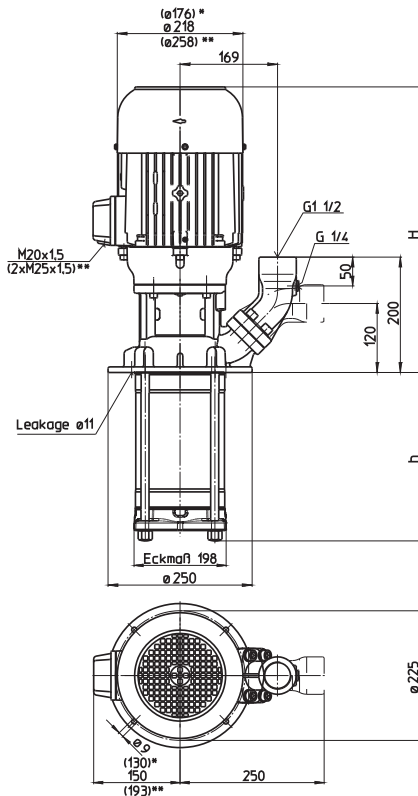

TH1102...1115

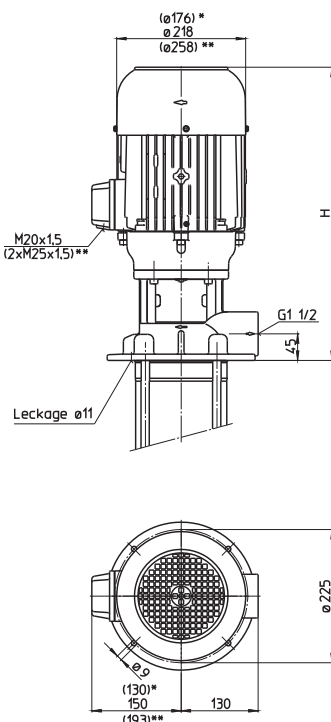

*) Dimensions for (S)TH1102...1104
**) Dimensions for (S)TH1110...1115

Type	Vol. del. at manom. del. head l/min /m	Height H mm	Depth of im- mersion h mm	Weight kg	Power kW	Voltage 3 ~ V	Fre- quen- cy Hz	Current A	Speed 1/min
(S)TH1102B180	150/30	433	182	34	1.49	460	60	2.7	3500
(S)TH1103B180	150/45	492	182	43	2.18	460	60	3.9	3500
(S)TH1104B280	150/59	492	278	44	2.94	460	60	5.1	3480
(S)TH1105B280	150/77	531	278	57	3.8	460	60	6.4	3520
(S)TH1106B280	150/90	531	278	58	4.55	460	60	7.9	3520
(S)TH1107B310	150/106	561	310	62	5.75	460	60	9.5	3520
(S)TH1108B380	150/121		374	64					
(S)TH1109B380	150/138	561	374	65	6.3	460	60	10.4	3510
(S)TH1110B470	150/152	640	470	97	8.6	460	60	13.7	3550
(S)TH1111B470	150/166			98					
(S)TH1112B470	150/180			99					
(S)TH1113B500	150/198	640	502	108	10.3	460	60	15.8	3550
(S)TH1114B570	150/212		566	109					
(S)TH1115B570	150/230			110					

Immersion Pumps

Series TH and FH use **closed impellers** in order to minimize power consumption and to optimize hydraulic pump efficiencies.

In addition, the TH series offers high pressures at short immersion depths. Inline pumps of the series FH can be used as **boosting pumps** if provided with positive inlet pressure. This inlet pressure can be provided by the central coolant supply or a feed pump. In such a setup, pumps of the series FH can raise the incoming pressure by up to 26 bar.

Extended length is possible. See medium pressure pumps features within the technical information section.

Applications

Types of fluid
 Industry water
 coolants
 cooling/cutting oils
 Kinematic viscosity
 ...25 mm²/s (25 cSt)
 Pumping temperature
 0...80° C

Construction

Pump body	cast iron
Cover	cast iron
Impellers	CrNi-steel
Shaft	CrNi-steel
Diffusers	CrNi-steel
Mechanical seal	SiC
O-rings	Viton
Optional:	
Pump body	CrNi-steel
Cover	CrNi-steel

Noise level

(S)TH1102...(S)TH1104	66 dBA
(S)TH1105...(S)TH1109	74 dBA
(S)TH1110...(S)TH1115	77 dBA

