

Pressure Boosting Pumps

FH6

Closed impellers



FH603...624

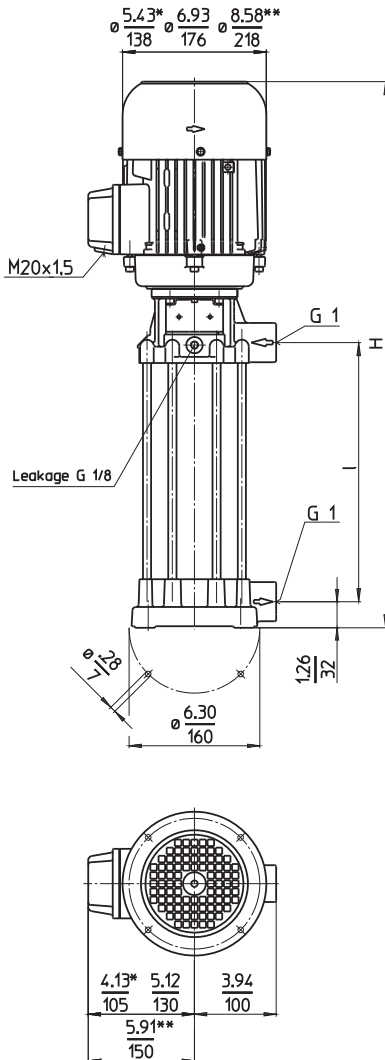

Dimensions in Inches / mm
 *) Dimensions FH603...FH605
 **) Dimensions FH612...FH624

Type	Flow at head GPM / Feet l/min / m	Height H inch mm	Length l Inch l mm	Weight Lbs kg	Power HP kW	Voltage 3~ V	Fre- quen- cy Hz	Current AMPS	Speed RPM
FH603S19	20/95 80/28	20.8 529	7.8 197	43.9 19.9	1.15 0.86	230 460	60 60	3.70 1.85	3440 3440
FH604S19	20/120 80/38	20.8 529	7.8 197	46.3 21	1.4 1.06	230 460	60 60	4.2 2.1	3440 3440
FH605S24	20/150 80/48	23.9 606	9.7 247	48.5 22	1.7 1.27	230 460	60 60	4.8 2.4	3440 3440
FH606S24	20/185 80/58	24.7 628	9.7 247	61.7 28	2.3 1.75	230 460	60 60	6.2 3.1	3470 3470
FH607S29	20/220 80/68	27.7 704	11.7 297	70.6 32	2.6 1.95	230 460	60 60	7.0 3.5	3480 3480
FH608S29	20/255 80/78	29.0 736	11.7 297	77.2 35	2.9 2.18	230 460	60 60	7.8 3.9	3500 3500
FH609S34	20/285 80/88	30.9 786	13.7 347	83.8 38	3.4 2.55	230 460	60 60	8.8 4.4	3480 3480
FH610S34	20/330 80/98	30.9 786	13.7 347	86.0 39.0	3.9 2.94	230 460	60 60	10.2 5.1	3480 3480
FH611S39	20/358 80/108	32.9 836	15.6 397	87.3 39.6					
FH612S39	20/395 80/118	32.6 829	15.6 397	115.3 52.3	4.6 3.45	230 460	60 60	12 6	3520 3520
FH613S49	20/420 80/128	36.6 929	19.6 497	117.3 53.2	5.1 3.8	230 460	60 60	12.8 6.4	3520 3520
FH614S49	20/455 80/139			118.0 53.5					
FH615S49	20/490 80/149	36.6 929	19.6 497	122.6 55.6	6.1 4.55	230 460	60 60	15.8 7.9	3520 3520
FH616S49	20/520 80/159			123.0 55.8					
FH617S59	20/555 80/168	40.5 1029	23.5 597	124.1 56.3					
FH618S59	20/580 80/178	41.7 1059	23.5 597	133.0 60.3	7.7 5.75	230 460	60 60	19.0 9.5	3520 3520
FH619S59	20/615 80/188			133.2 60.4					
FH620S59	20/645 80/198			133.4 60.5					
FH621S69	20/675 80/206	45.6 1159	27.4 697	134.9 61.2					
FH622S69	20/705 80/214			135.2 61.3					
FH623S69	20/735 80/222	45.6 1159	27.4 697	142.2 64.5	8.4 6.3	230 460	60 60	20.8 10.4	3510 3510
FH624S69	20/765 80/232			142.7 64.7					



Pressure Boosting Pumps

series TH and FH use closed impellers in order to minimize power consumption and to optimize hydraulic pump efficiencies.

In addition, the TH series offers high pressures at short immersion depths. Inline pumps of the series FH can be used as boosting pumps if provided with positive inlet pressure. This inlet pressure can be provided by the central coolant supply or a feed pump. In such a setup, pumps of the series FH can raise the incoming pressure by up to 375 PSI (26 bar).

A frequency alternator can be supplied for special applications or for matching the pump characteristic to a specific duty point. See page "Control/Regulation" in the Technical Information section of this catalog for further information.

Applications

- Types of fluid
 - Industry water
 - coolants
 - cooling/cutting oils
- Kinematic viscosity
 - 4.6 SSU (1 mm²/s)
 - higher viscosity upon request
- Pumping temperature
 - 30...175 °F (0...80 °C)

Construction

Pump body	cast iron
Cover	cast iron
Impellers	CrNi-steel
Shaft	CrNi-steel
Diffusers	CrNi-steel
Mechanical seal	SiC
O-rings	Viton®
Optional:	
Pump body	bronze
Cover	bronze
Noise level	
FH603...FH605	61 dBA
FH606...FH611	66 dBA
FH612...FH624	75 dBA

