

# Jansen

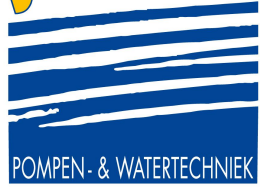

Hoogeindsestraat 5  
NL - 5447 PD Rijkevoort  
Nederland  
T : +31 (0) 485 - 371318  
F : +31 (0) 485 - 371918  
info@pompentechniek.nl  
www.pompentechniek.nl



# ROBOT PUMPS



## RT - TURBOTEX PUMPS

## RT- Turbotex pumps

The Robot submersible Turbotex pumps form the ultimate solution in today's pumping technology. The self cleaning blade leading edge effectively deals with fibrous materials and other materials that are found in waste water. The smooth passage of water and solids through the Turbotex impeller makes them first choice for product pumping or wherever flow disturbance is unacceptable including activated sludge.

The closed design of the impeller guarantees constant high performance with a minimum of maintenance and maximum reliability. No impeller to volute adjustments are necessary to keep efficiencies at design level and maintaining low energy consumption.

### Features

#### Self cleaning impeller

The Turbotex impeller effectively deals with one of the major problems in waste water pumping, fibrous materials. At the suction side, the impeller blade is extended in such a way that the inlet is almost parallel with the direction of flow. Fibrous materials are pushed along the blade into the wide impeller passage by the main flow. The impeller passage is designed with equal cross section, avoiding dead corners where clogging might start.

#### No adjustments - low maintenance

At the suction side, two wear rings in series are provided that do not require re-adjustments to maintain performance at design level. Provisions in the wear rings avoid jamming on the impeller in the volute. The risk for pumps running at reduced output and efficiencies is greatly eliminated with only minimum maintenance.

#### Low turbulence - low product damage

The favourable shape of the impeller inlet ensures smooth passage of water and solids, avoiding excessive turbulence and preventing damage to the pumped particles. This makes Turbotex pumps first choice for product pumping, i.e. in food processing or where flow disturbance is unacceptable as for instance in pumping activated sludge.

#### High efficiency - adjustable flow

The Turbotex pumps not only show high efficiencies over a broad operating range, but moreover the design of the impeller outlet allows impeller trim. This feature, not commonly available in traditional spiral vane pumps enhances energy saving as pumps do not run unnecessarily above the required capacity.

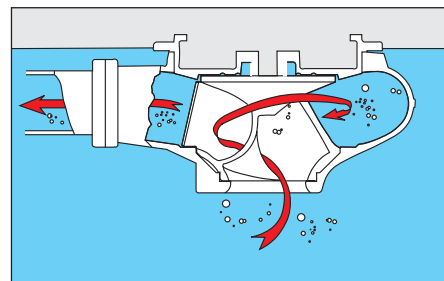
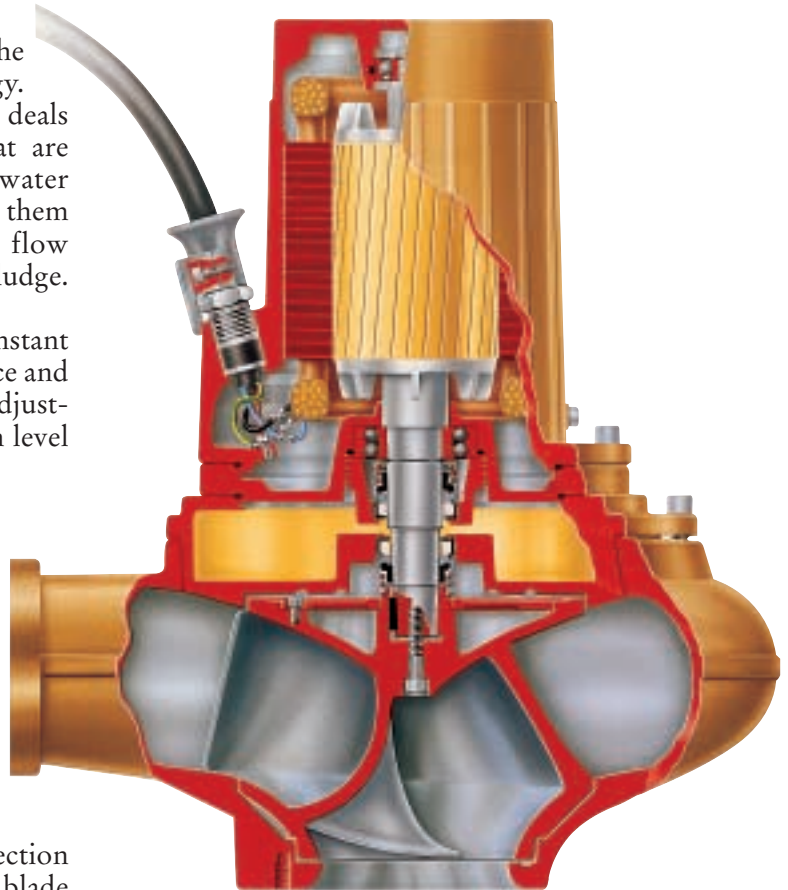

#### Low wear-constant high performance

The closed design of Turbotex impellers ensures that abrasives have limited or no effect on the impeller to volute clearance and hence efficiency. The risk for sudden drops in performance has been significantly reduced.

# Characteristics

RT20 series

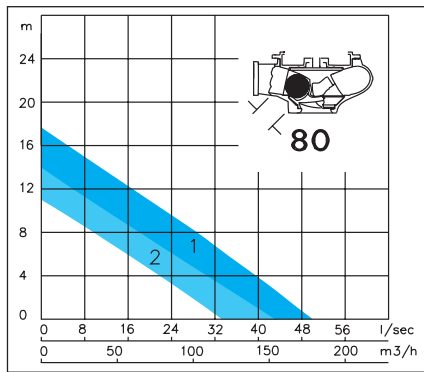

Nr	Model	Motor [kW]	Speed [min <sup>-1</sup> ]	Outlet [mm]	A [mm]	B [mm]
1	RT2030DG	3.5	1450	100	420	520
2	RT2031DD	2.2	1450	100	420	520

RT40 series

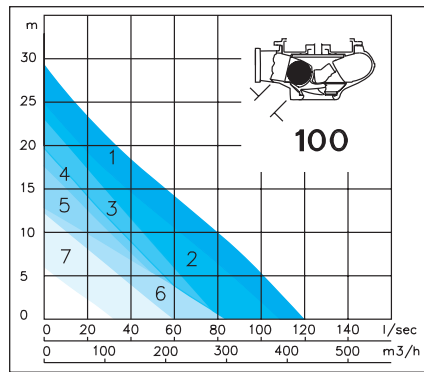

Nr	Model	Motor [kW]	Speed [min <sup>-1</sup> ]	Outlet [mm]	A [mm]	B [mm]
1	RT4042DZ	12	1450	150	665	773
2	RT4042DU	9.5	1450	150	665	773
3	RT4040DO	7.5	1450	100	495	620
4	RT4040DL	6	1450	100	495	620
5	RT4040DJ	5	1450	100	495	620
6	RT4042FH	4	960	150	665	708
7	RT4040FE	2.4	960	100	495	620

RT60 series

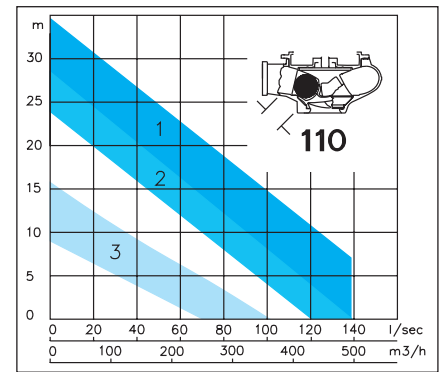

Nr	Model	Motor [kW]	Speed [min <sup>-1</sup> ]	Outlet [mm]	A [mm]	B [mm]
1	RT6040LF	22	1450	150	705	950
2	RT6040LD	16	1450	150	705	950
3	RT6040FR	9	960	150	705	950

RT60 series

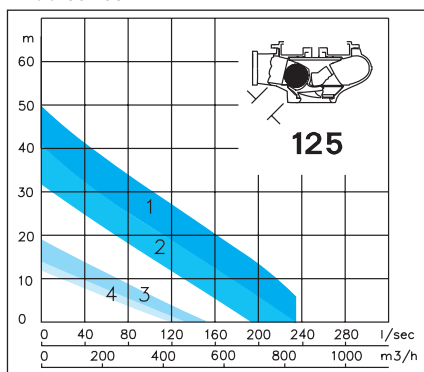

Nr	Model	Motor [kW]	Speed [min <sup>-1</sup> ]	Outlet [mm]	A [mm]	B [mm]
1	RT6050LL	48	1450	200	865	1090
2	RT6050LI	34	1450	200	865	1015
3	RT6050FZ	13	960	200	865	950
4	RT6050FR	9	960	200	865	950

RT80 series

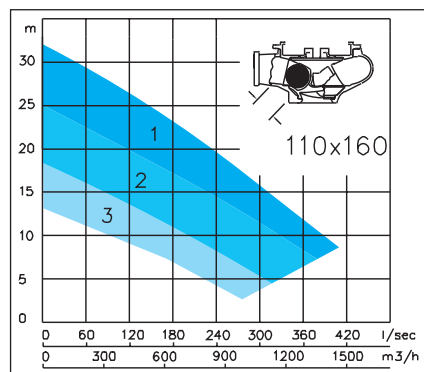

Nr	Model	Motor [kW]	Speed [min <sup>-1</sup> ]	Outlet [mm]	A [mm]	B [mm]
1	RT8040NO	60	960	250	1160	1375
2	RT8040PM	48	750	250	1160	1375
3	RT8040PG	26	750	250	1160	1360

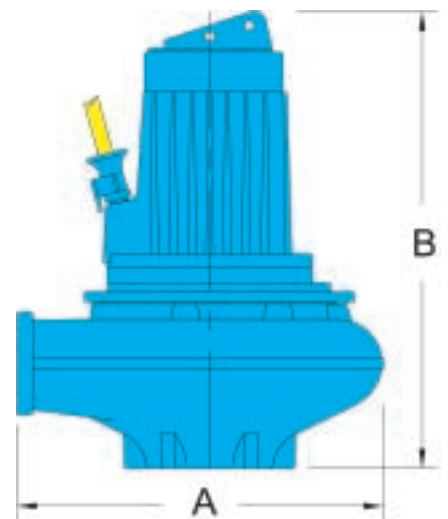

## Design Features

**Motor:** class F (155°F/311°F).

**Bearings:** heavy duty (thrust) bearings, greased for life.

**Shaft:** stainless steel.

**Shaft sealing:** Two independent mechanical seals, run in oil. At the pump side silicon carbide runs on ceramic, at the motor side carbon on ceramic.

**Oil housing:** with flexible rubber bellows.

**Back vanes:** with spiral groove in the seal housing. Prevent solids entering the seal area and reduce the pressure on the seals for longer seal life.

**Impeller:** self cleaning, effectively deals with fibrous materials. No flow disturbance and low product damages. RT 80 with twin blades for optimum hydraulic balance and smooth vibration free running

**No adjustments:** closed impeller to minimise the effects of wear. Two wear rings in series that do not require re-adjustments for constant long term high performance with minimum maintenance.

**Bolts & Nuts:** stainless steel.

## Options available

	Versions		Impeller materials	
	Flame-proof	Cooling-system	Wear resistant	Stainless steel
RT2030	●	●	●	
RT2031	●	●	●	●
RT4040	●	●	●	
RT4042	●	●	●	
RT6040	●	●	●	
RT6050	●	●	●	
RT8040		●	●	

## Options

**Flame proof motors:** certified to European standards EN 50014/18/19 (BS 5501), class EEx de IIB T3 or T4, and to American FMRC standard, class 1, division 1, groups C&D T4.

**Cooling jacket:** for continuous dry running at full load, with internal water circulation or for external water supply. Available for larger pumps. Seal flushing is optional.

**Seal leak monitor:** detects water ingress in both motor- and oil housing.

**Thermostats:** standard for all flameproof pumps and units with cooling system and optional for all other pumps.

**Special materials:** many components are available in non standard materials like stainless steel, bronze, hardened sg cast iron etc.

**Renewable wear rings:** available upon demand.

## Products from Robot Pumps B.V.:

### Submersible pumps



- RW Vortex Pumps
- RT Turbotex Pumps
- RS Grinder Pumps
- RC Channel Pumps
- RD Slurry Pumps
- RV Heavy Duty Slurry Pumps

### Pumps for dry installation



- BW Vortex Pumps
- BT Turbotex Pumps
- BD Slurry Pumps

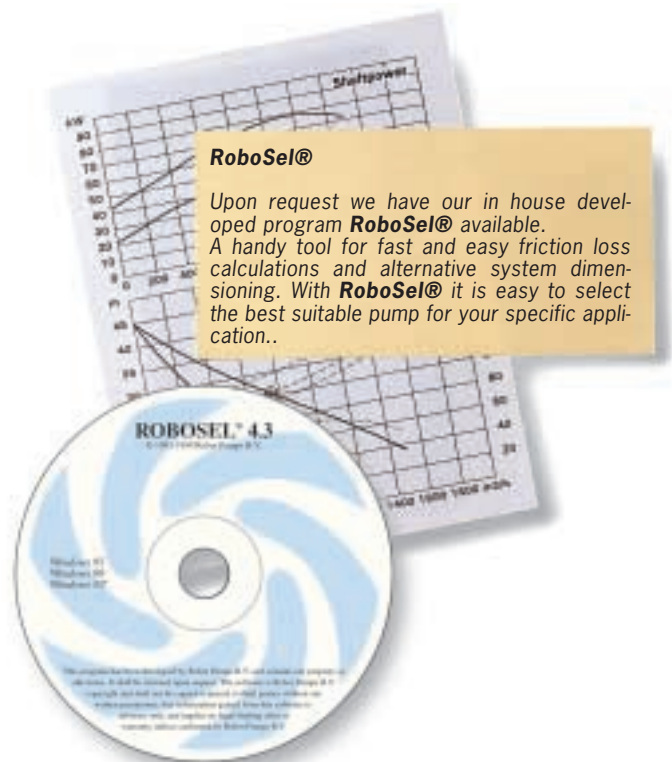

## Typical applications

### Sewage

Sewage treatment plants, sewage pumping stations, shopping malls, hotels, restaurants, high rise buildings etc.

Sewage, sewage by-pass, liquid manure, activated sludge, heavy-, primary- and digester sludge, sludge circulation, effluent.

### Food processing

Food and pet food factories, abattoir's, canneries, breweries and distilleries, sugar factories, meat and fish industrie, dairies.

Food and food waste, vegetable waste, slaughter waste, wash water.

### General industry

Car and motor industry, paper mills, power plants, rubber industry, offshore and shipbuilding, leather and textile industry, steel works. Paper pulp, process and cooling water, viscous liquids, latex, cellulose, bilge water, raw water.

### Water Control

Storm water pumping stations, storm water overflow collecting sumps, irrigation pumps, land drainage pumps, tunnel drainage, quarry and mine de-watering, land reclamation.



## Options available

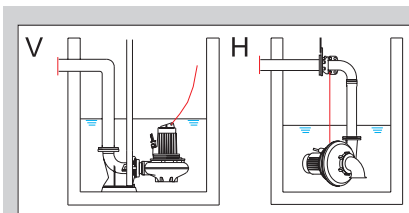

Pumps are available for permanent fixed installation, using the guide rail coupling V or the header coupling H, that is installed above the water level.

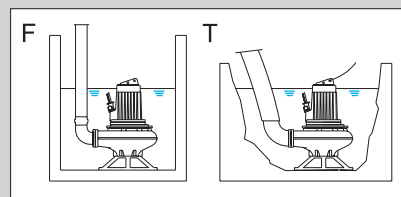

All pumps can be delivered with stand and discharge adapter for semi permanent free-standing installation F or for transportable use T.

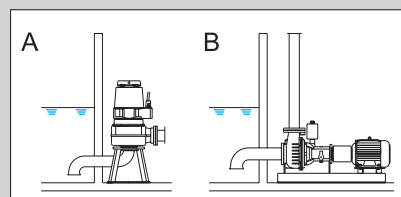

Pumps with cooling system can be used in permanent dry flood-proof immersible installation A. For conventional dry installation B refer to the BT series brochure.

