

# RoboWhirl

an effective solution for agitating  
and mixing up settled solids



# RoboWhirl

an effective solution for agitating and mixing up settled solids

The RoboWhirl was originally designed for keeping the sumps for sewage pumps clean from sludge and settlement of solids. At the same time it can prevent the formation of floating layers on the liquid surface. The unique design makes the RoboWhirl equally effective in settling ponds, storm water overflow tanks and similar applications, in particular where the water depth is limited and propeller mixers cannot be used.

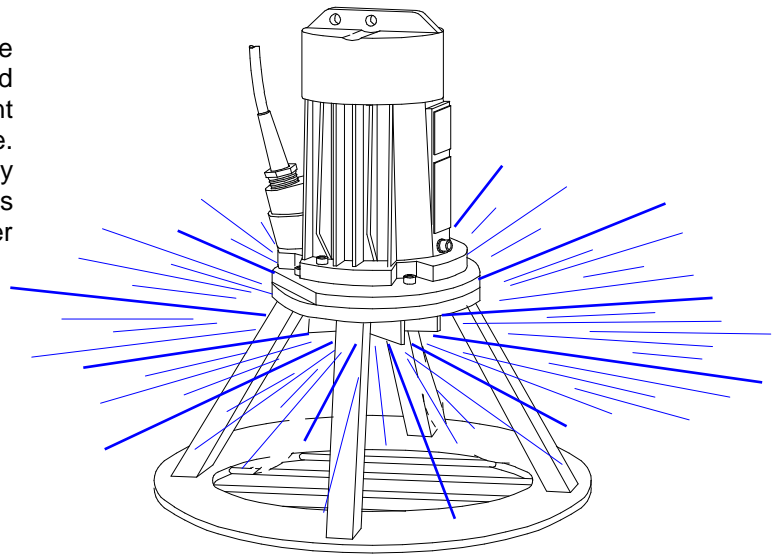

## Unique features for the RoboWhirl

- Can work at water levels as low as 30 cm.
- Works very efficiently in shallow waters.
- Reduces energy consumption as it creates its main stirring effect in the lower section of the water, where it is most needed.
- Provides agitation and mixing over a full 360° around the RoboWhirl.
- Can be used anywhere, independent of pumps.
- Can be installed either as a permanent or temporary freestanding solution.
- Needs only a small foot print for installation. There is no need for a large unobstructed area in front of it.
- Can easily be moved around in larger sumps to find the optimum location or to clean remote corners.



## How it works

In its essence the RoboWhirl is a vortex pump without pump casing. The impeller is located underneath the motor, close to the sump floor. Water will leave the impeller at high velocity and create a strong radial flow. This in turn results in the agitation and mixing effect on either settled solids, or those already in solution. The stirring effect is maximised close to the floor, but extends throughout the sump to the water surface depending on sump geometry and size. This will prevent the formation of a floating layer on the surface.

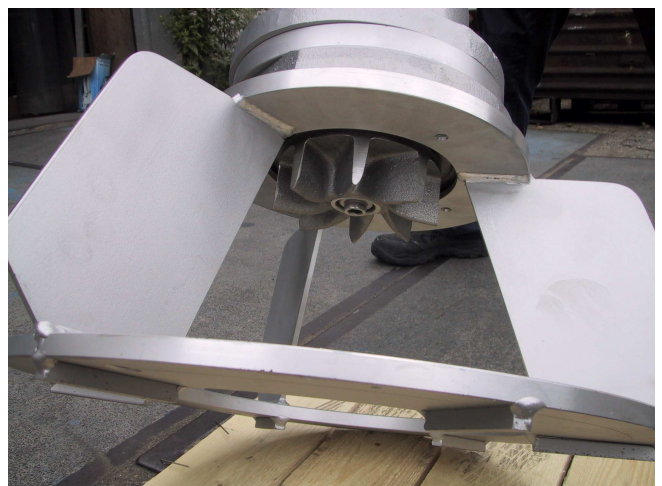
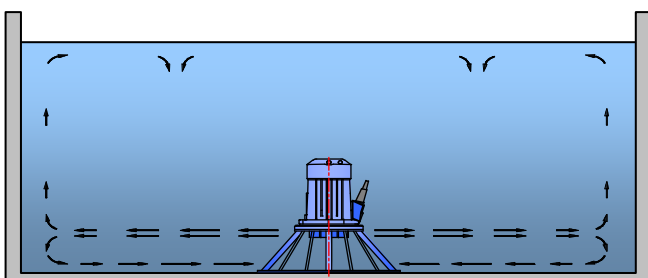

## Typical applications

- **Sewage pumping sumps.**  
The RoboWhirl is most effective as it whirls up settled sludge and solids at the same level as the pump suction. The RoboWhirl can be used during the full pump cycle until the pumps are switched off.
- **Settling ponds.**  
Generally it will cost less energy to whirl up settled solids in shallow waters. This makes stirring extremely effective and economic.
- **Storm water collecting pits.**  
During emptying the RoboWhirl is used to bring settled solids in suspension again.
- **Homogenization tanks.**  
The use of RoboWhirl in homogenization applications is possible, provided agitating is the main task. Mixing is different from bottom to surface.



## Installation

The most widely used installation type is freestanding. The smaller units can optionally be provided with a stand with extra fins to prevent the unit from rotating. As an alternative the RoboWhirl can be suspended using 2 chains as shown in the picture or any other suitable way. There is no need for an access opening directly above the unit itself.

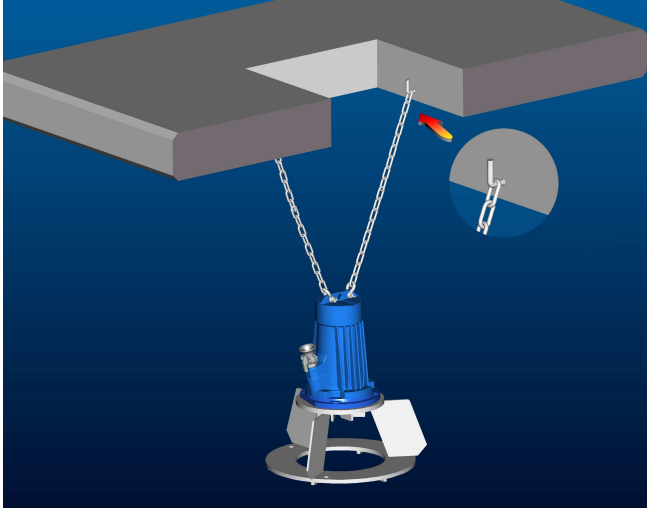

## Location of the RoboWhirl

The RoboWhirl proved to be best when its off centre installed. This will create an additional flow along the walls, cleaning up settlements at these parts of the tanks too.

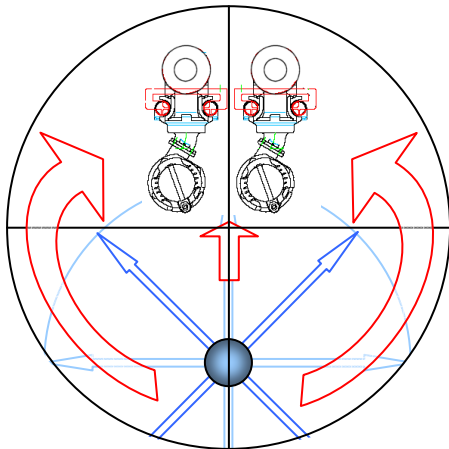

## Versions available

The RoboWhirl is available from 1,5 to 48 kW in basic and explosion proof versions. The basic construction is cast iron, but for tough applications different materials are available. For abrasives NiHard 4 hydraulic parts are the best choice. For corrosive liquids we can supply parts or complete units in stainless steel AISI 316 or duplex stainless steel AISI 329. RM60 is with cast iron motor only.

## Motor cooling

In most applications the motor running uncooled will not cause problems. When running prolonged time at full load motor cooling must be considered. Winding protection by thermostats is available.

## Effective cleaning area

The effective cleaning area greatly depends on the nature of the solids and the sump geometry. Solids will settle when the flow velocity drops below the critical value. For sewage we recommend 0.75 m/s, for sand 2.3 m/s or higher. Since power is squared to the velocity, this means that for sand we roughly need 10 times the power for sewage. Our recommendation is 100 W/m<sup>3</sup> for sewage and 1.000 W/m<sup>3</sup> for sand. From actual installations we know that it is sufficient for calculations when this energy level is met in the lower section of the tank. A water height of 3 to 4 times the distance from impeller to floor proved generally accurate. The effective cleaning area's for these conditions are listed in the table below.

For very small particles that will not settle easily, the effective working distance can extend the values in the table below.

It's also obvious that more power and time is needed to remove sediments than to prevent the formation of such sediments, in particular when the layer is heavily compacted.

RoboWhirl	RM21DC	RM21DD	RM21DG	RM40DJ	RM40DL	RM40DO	RM40DZ	RM60LF	RM60LI	RM60LL
Power input kW	1,8	2,5	3,8	5,1	7,1	8,6	13,5	24	31	47
Water level m <sup>1)</sup>	0,6	0,6	0,6	0,6	0,6	0,6	0,6	0,75	0,75	0,75
Cleaning diameter for 100 W/m <sup>3</sup>	6,2	7,3	9,0	10,4	12,3	13,5	16,9	20,2	22,9	28,2
Cleaning diameter for 1000 W/m <sup>3</sup>	2,0	2,3	2,8	3,3	3,9	4,3	5,4	6,4	7,3	8,9

<sup>1)</sup> Taken 3 times the distance from impeller to floor.