

BOOSTER UNITS

Series HWX / EPA / HMP – multistage



EPA 15-3E

FEATURES HWX / EPA:

- self-priming injection pump, pump housing made of stainless steel
- High quality motor, shaft made of stainless steel
- thermal overload protection
- injector, diffusor and impeller made of polyamide plastic
- EPA motor housing made of stainless steel, HWX motor housing from polyamide plastic
- sealed with a mechanical seal
- pressure switch (from 0 – 5 bar)
- suction and discharge tap 1"
- suction head up to 8,5 m
- diaphragm tank in different versions

FEATURES HMP:

- low operation noise self-priming multistage centrifugal pump
- High quality motor, shaft made of stainless steel
- thermal overload protection
- pump housing and screws made of stainless steel; motor housing in aluminium; guide-/gear wheels in wear-resistant polyamide plastic
- sealed with a mechanical seal
- pressure switch (from 0 – 5 bar)
- suction and discharge tap 1"
- suction head up to 8,5 m
- diaphragm tank in different versions

TECHNICAL DATA:

20 l diaphragm tank painted steel

Type	Item-No.	P1 [kW]	P2 [kW]	U [V]	I [A]	n [min ⁻¹]	Qmax [m ³ /h]	Hmax [m]	Weight [kg]
HWX 3200	15577	0,6	0,35	230	2,9	2800	2,9	41	18,0
HWX 3800	15582	1,0	0,7	230	4,4	2800	4,0	46	19,0
HWX 5200	15585	1,6	1,3	230	7,0	2800	7,0	60	23,1
EPA 11-3	15595	0,6	0,35	230	2,9	2800	2,9	41	18,0
EPA 15-3	15602	1,0	0,7	230	4,4	2800	4,0	46	19,0
HMP 350	17070	1,0	0,7	230	4,4	2800	4,3	44	19,5
HMP 450	15609	1,7	1,3	230	7,4	2800	6,0	50	25,1
HMP 255	15619	1,7	1,4	230	7,4	2800	7,0	57	24,3

20 l diaphragm tank maintenance-free, powder-coated

- Feet and Pump Stand Plastic
- vessel lining with untreated polypropylene
- high-quality butyl membrane (4 year warranty on the membrane and membrane tank)

Type	Item-No.	P1 [kW]	P2 [kW]	U [V]	I [A]	n [min ⁻¹]	Qmax [m ³ /h]	Hmax [m]	Weight [kg]
HWX-P 3200	15578	0,6	0,35	230	2,9	2800	2,9	41	18,0
HWX-P 3800	15583	1,0	0,7	230	4,4	2800	4,0	46	19,0
HWX-P 5200	15586	1,6	1,3	230	7,0	2800	7,0	60	23,1
EPA-P 11-3	15596	0,6	0,35	230	2,9	2800	2,9	41	18,0
EPA-P 15-3	15603	1,0	0,7	230	4,4	2800	4,0	46	19,0
HMP-P 350	17072	1,0	0,7	230	4,4	2800	4,3	44	19,5
HMP-P 450	15610	1,7	1,3	230	7,4	2800	6,0	50	25,1
HMP-P 255	15623	1,7	1,4	230	7,4	2800	7,0	57	24,3

20 l diaphragm tank stainless steel

Type	Item-No.	P1 [kW]	P2 [kW]	U [V]	I [A]	n [min ⁻¹]	Qmax [m ³ /h]	Hmax [m]	Weight [kg]
HWX-E 3200	15589	0,6	0,35	230	2,9	2800	2,9	41	18,0
HWX-E 3800	15590	1,0	0,7	230	4,4	2800	4,0	46	19,0
HWX-E 5200	15591	1,6	1,3	230	7,0	2800	7,0	60	23,1
EPA 11-3E	15598	0,6	0,35	230	2,9	2800	2,9	41	18,0
EPA 15-3E	15605	1,0	0,7	230	4,4	2800	4,0	46	19,0
HMP 350 E	17071	1,0	0,7	230	4,4	2800	4,3	44	19,5
HMP 450E	15538	1,7	1,3	230	7,4	2800	6,0	50	25,1
HMP 255E	15620	1,7	1,4	230	7,4	2800	7,0	57	24,3

All booster units are also available with larger diaphragm tank:

- 60 l steel painted
- 50 l stainless steel
- 60 l powder-coated, maintenance-free and 4-year warranty on tank membrane and membrane

Characteristics see page 47

Series HWX / EPA / HMP multistage

DIMENSIONS FOR 20 L DIAPHRAGM TANKS:

EPA / HMP 350 / HMP 450

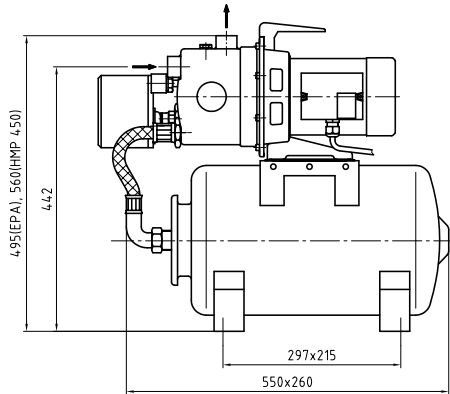

HMP 255

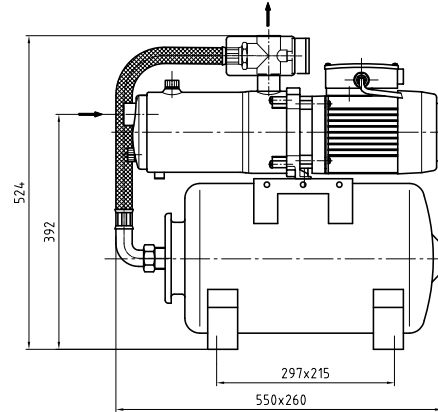

HWX

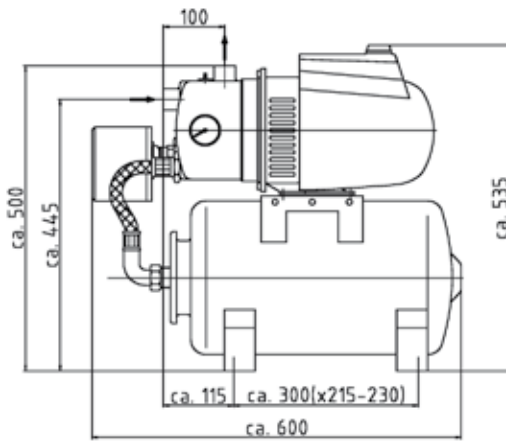

HAE 3200 – 3800 DIMENSIONS:

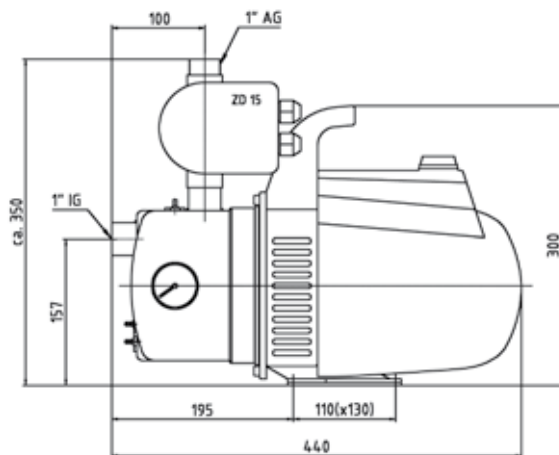

DELIVERY CONTENTS:

- plug-in, with 1,5 m power
- on / off switch (for EPA only)

APPLICATIONS:

- watering of home and garden
- water supply