

DRENAG 1400 - 1800

DRAINAGE PUMPS



CLEAN AND GREY WATER ON BUILDING SITES



Submersible pump with cast iron pump body, motor casing and adjustment ring impeller. Cast iron adjustment disk coated with abrasion-proof rubber. Stainless steel shaft, handle, filter, bolts and screws. Silicon/carbide mechanical seal, inspectionable oil chamber. Continuous duty submersible induction motor, in a watertight casing. Rotor mounted on oversized greased sealed-for-life ball bearings. Thermal protection in the windings, to be connected to the control panel. 10 mt of neoprene rubber power cable.

In order to operate, the pumps must be equipped with a control and protection system, supplied separately and not connected to the electropumps.

Operating range: from 6 to 33 m³/h with head up to 19,2 mt for the single-phase version and 21,5 mt for the three-phase version.

Liquid quality requirements: sandy, muddy or sludgy water from building sites, clean waste water, rain water, ground water, fountain, river or lake water, always non aggressive.

Liquid temperature range: from 0°C to +55°C.

Free passage through the suction grid: 12 mm.

Maximum immersion depth: 10 mt.

Installation: fixed or portable in a vertical position.

Liquid temperature range: from 0°C to +55°.

TECHNICAL DATA

MODEL	CODE	ELECTRICAL DATA						
		VOLTAGE 50 HZ	P1 MAX kW	P2 NOMINAL		In A	CAPACITOR	
				kW	HP		µF	Vc
DRENAG 1400 M	103010040	1X230 V~	2	1,1	1,5	9,2	40	450
DRENAG 1800 T	103010160	3X400 V~	2,3	1,5	2,0	4,4	-	-

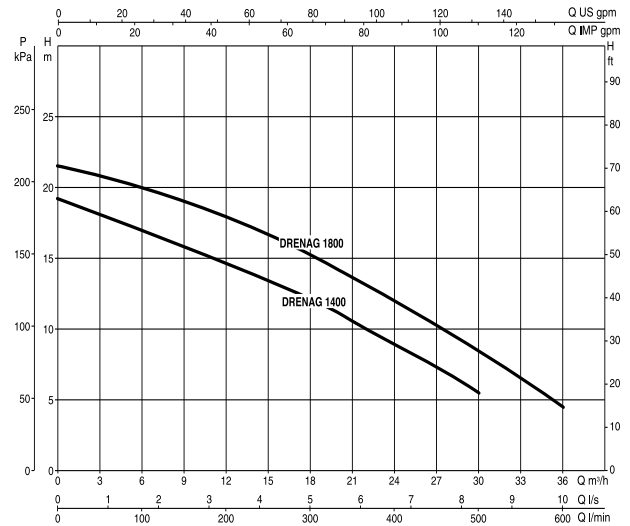

DIMENSIONS AND WEIGHTS

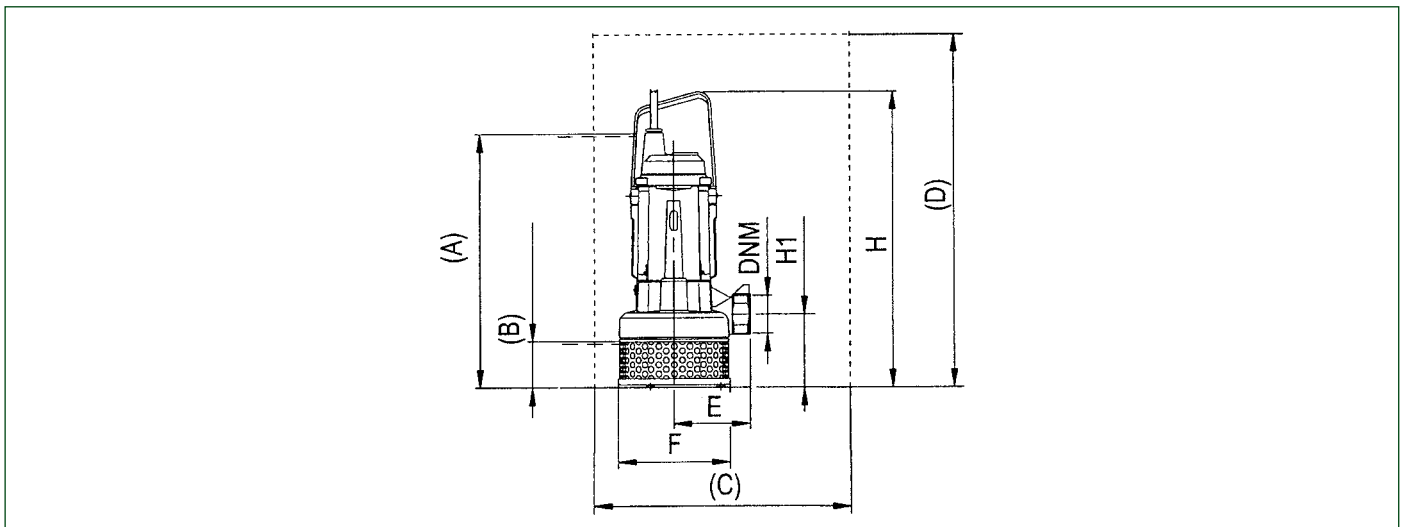

MODEL	A	B	C	D	E	FØ	DNM GAS	H	H1	FREE PASSAGE mm	Q.TY X PALLET	WEIGHT KG
DRENAG 1400 M	500	90	500x500 min	600 min	150	219	2"	584	144	12	6	44,2
DRENAG 1800 T	500	90	500x500 min	600 min	150	219	2"	584	144	12	6	44