

Submersible drainage pumps

⇒ for clear water



Hoogeindsestraat 5
NL - 5447 PD Rijkevoort
Nederland
T : +31 (0) 485 - 371318
F : +31 (0) 485 - 371918
info@pompentechnik.nl
www.pompentechnik.nl



PERFORMANCE RANGE

- Flow rate up to **400 l/min** (24 m³/h)
- Head up to **27 m**

APPLICATION LIMITS

- Immersion depth:
 - **1.5 m** with 5 m long power cable
 - **5 m** with 10 m long power cable
- Maximum liquid temperature **+40 °C**
- Solids passage:
 - up to **Ø 10 mm** for D8-D10-D15
 - up to **Ø 6 mm** for D18-D20
 - up to **Ø 3 mm** for D30
- Suction level:
 - **23 mm** above ground level for D8-D10-D18-D20
 - **15 mm** above ground level for D15-D30
- **220 mm** minimum immersion depth for continuous service

CONSTRUCTION AND SAFETY STANDARDS

- Complete with **5 m** long power cable
- Float switch for single-phase versions

EN 60335-1
IEC 60335-1
CEI 61-150

EN 60034-1
IEC 60034-1
CEI 2-3



INSTALLATION AND USE

Designed to pump **clear or slightly dirty water**, these pumps are suitable for use in domestic, civil and professional applications and in particular for draining flooded areas such as cellars and garages, for draining swimming pools and reservoirs and for the disposal of non-sewage waste water.

These pumps distinguish themselves for their reliability, which can be best appreciated under automatic operating conditions in fixed installations.

PATENTS - TRADE MARKS - MODELS

- Patent pending n° BO2008A000494, BO2008A000496

OPTIONALS AVAILABLE ON REQUEST

- Pumps with a **10 m** long power cable
 - ⇒ N.B. Standard EN 60335-2-41 states that the power cable must be 10 m long for outdoor applications
- Single-phase pumps without float switch
- Other voltages or 60 Hz frequency

GUARANTEE

2 years subject to terms and conditions

CERTIFICATIONS



AN30



IPOMTECT-168

CHARACTERISTIC CURVES AND PERFORMANCE DATA

50 Hz n= 2900 1/min

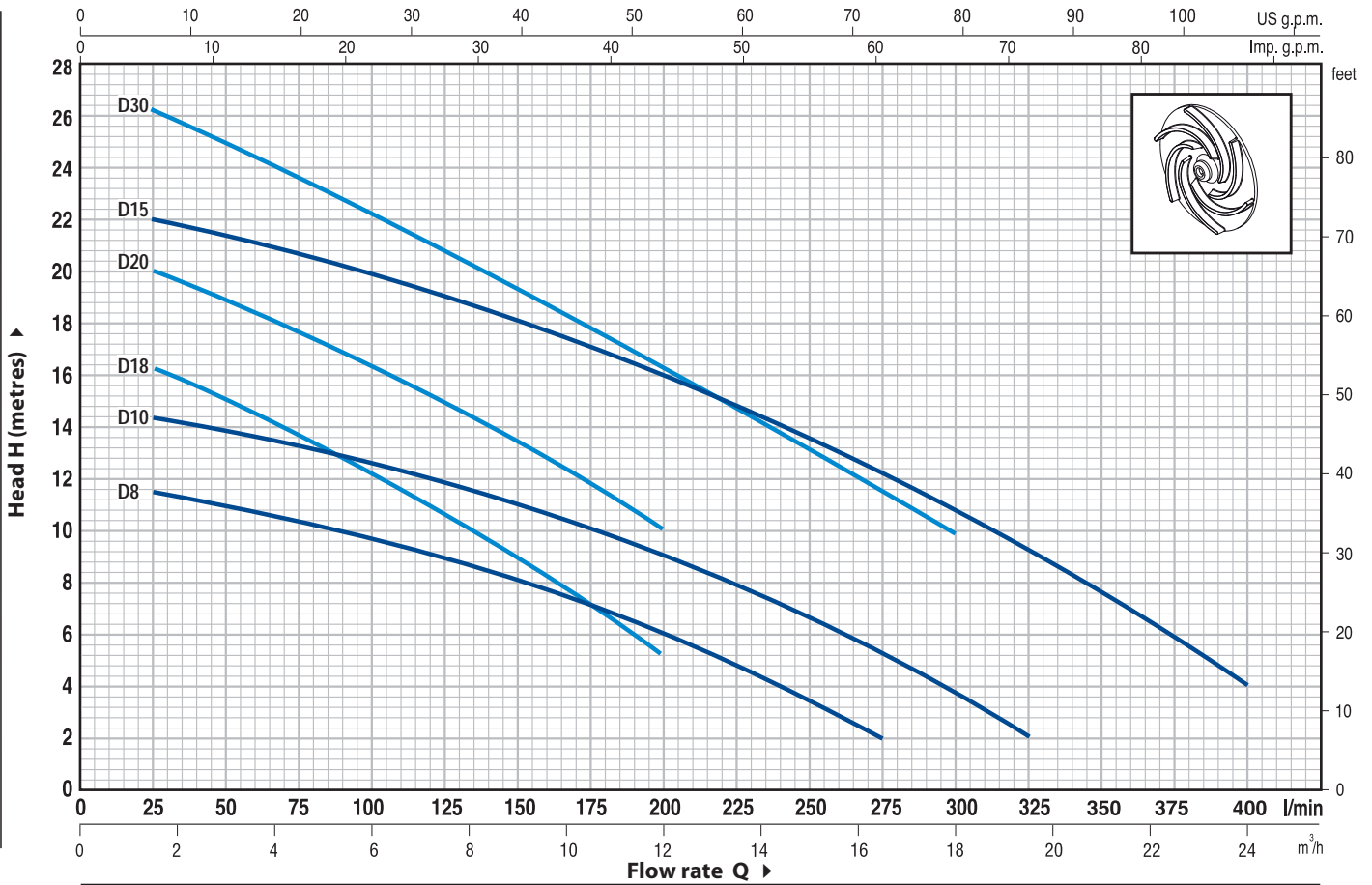

MODEL		POWER		Q	H metres																		
Single-phase	Three-phase	kW	HP		m³/h	0	1.5	3.0	4.5	6.0	7.5	9.0	10.5	12.0	13.5	15.0	16.5	18.0	19.5	21.0	24.0		
				l/min	0	25	50	75	100	125	150	175	200	225	250	275	300	325	350	400			
Dm 8	-	0.55	0.75	H metres	12	11.5	11	10.5	9.8	9	8.2	7.2	6	4.8	3.5	2							
Dm 10	D 10	0.75	1		15	14.5	14	13.2	12.5	11.8	11	10	9	8	6.8	5.4	3.5	2					
Dm 15	D 15	1.1	1.5		23	22	21.5	20.5	20	19	18	17	16	15	13.5	12	11	9	7.5	4			
Dm 18	-	0.55	0.75		17	16.5	15	13.5	12	10.7	9	7.7	5										
Dm 20	D 20	0.75	1		21	20	19	17.5	16	15	13.5	12	10										
Dm 30	D 30	1.1	1.5		27	26	25	23.5	22	21	19.5	18	16	14.5	13	11.5	10						

Q = Flow rate H = Total manometric head

Tolerance of characteristic curves in compliance with EN ISO 9906 App. A.

POS.	COMPONENT	CONSTRUCTION CHARACTERISTICS			
1	PUMP BODY	Cast iron, with threaded port in compliance with ISO 228/1			
2	SUCTION FILTER	Stainless steel AISI 304 (with mesh filter for D30)			
3	SUCTION PLATE	Stainless steel AISI 304			
4	IMPELLER	Technopolymer open type (closed for D30)			
5	MOTOR CASING	Stainless steel AISI 304			
6	MOTOR CASING PLATE	Stainless steel AISI 304			
7	MOTOR SHAFT	Stainless steel EN 10088-3 - 1.4104			
8	SHAFT WITH DOUBLE SEAL AND OIL CHAMBER				
	Seal	Shaft			
	<i>Model</i>	<i>Diameter</i>	<i>Stationary ring</i>	<i>Rotational ring</i>	<i>Elastomer</i>
	MG1-14 SIC	Ø 14 mm	Ceramic	Silicon carbide	NBR
9	LIP SEAL	Ø 15 x Ø 24 x H 5 mm (Ø 16 x Ø 24 x H 5 mm for D15, D30)			
10	BEARINGS	6203 ZZ / 6203 ZZ			
11	CAPACITOR				
	Pump	Capacitance			
	<i>Single-phase</i>	<i>(230 V or 240 V)</i>	<i>(110 V)</i>		
	Dm8				
	Dm10	20 µF 450 VL	30 µF 250 VL		
	Dm18				
	Dm20				
	Dm15	25 µF 450 VL	-		
	Dm30				
12	ELECTRIC MOTOR				
	<ul style="list-style-type: none"> - Single-phase 230 V - 50 Hz with thermal overload protector built-in to the winding - Three-phase 400 V - 50 Hz - Insulation: F class - Protection: IP 68 				
13	POWER CABLE				
	5 metre long "H07 RN-F" cable (with Schuko plug on single-phase versions only)				
14	FLOAT SWITCH				
	(only for single-phase versions)				

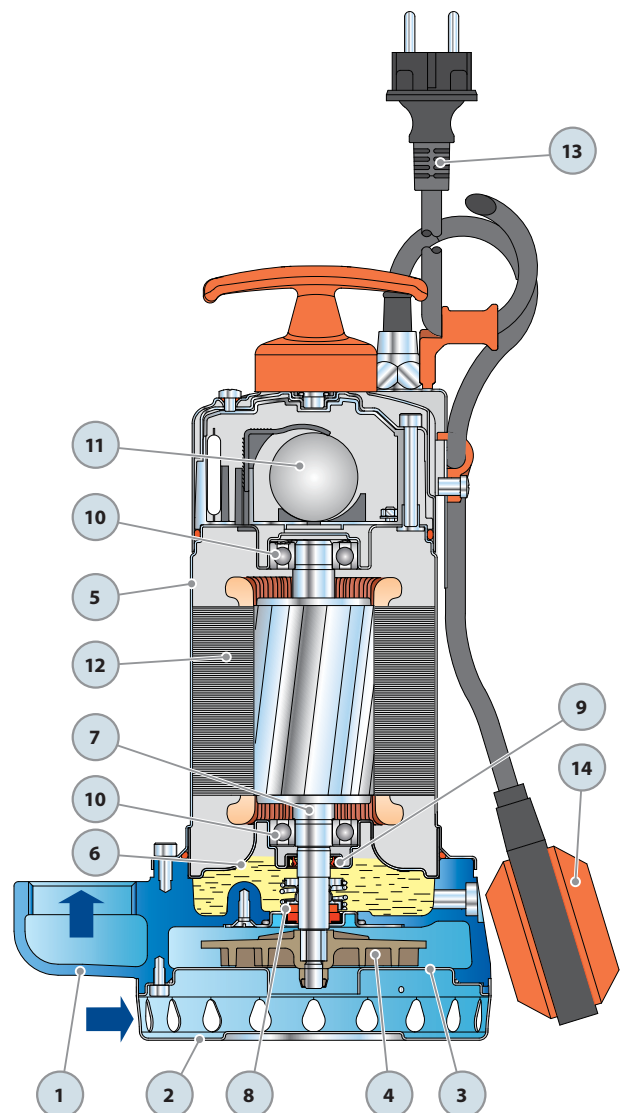

DIMENSIONS AND WEIGHT

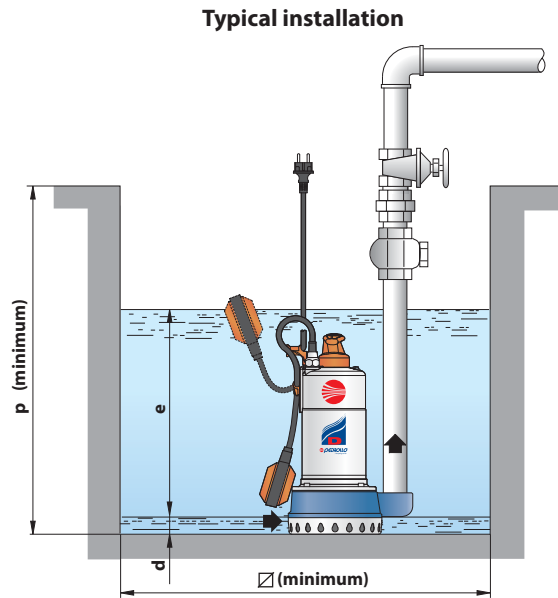
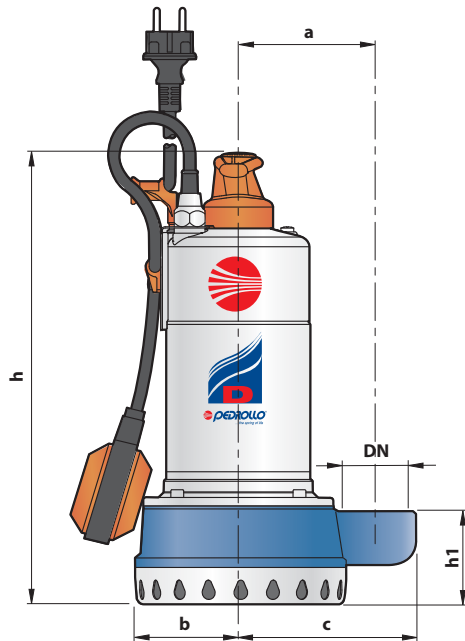

MODEL		PORT DN	DIMENSIONS mm									kg	
Single-phase	Three-phase		a	b	c	h	h1	d	e	p	Ø	1~	3~
Dm 8	-	1½"	105	81	136	352	72	23	variable	500	500	11.7	-
Dm 10	D 10											12.7	11.6
Dm 15	D 15		110	90	140	371	85	15				14.7	13.7
Dm 18	-		105	81	136	352	72	23				11.8	-
Dm 20	D 20											13.0	11.7
Dm 30	D 30		110	90	140	371	85	15				15.0	14.0

ABSORPTION

MODEL	VOLTAGE (single-phase)		
	230 V	240 V	110 V
Single-phase			
Dm 8	3.4 A	3.4 A	6.9 A
Dm 10	5.2 A	5.2 A	10.5 A
Dm 15	7.9 A	7.9 A	-
Dm 18	3.8 A	3.8 A	7.2 A
Dm 20	5.4 A	5.4 A	11.0 A
Dm 30	7.2 A	7.2 A	-

MODEL	VOLTAGE (three-phase)			
	230 V	400 V	240 V	415 V
Three-phase				
D 10	3.6 A	2.1 A	3.6 A	2.1 A
D 15	6.0 A	3.5 A	6.0 A	3.5 A
D 20	3.6 A	2.1 A	3.6 A	2.1 A
D 30	6.0 A	3.5 A	6.0 A	3.5 A

PALLETIZATION

MODEL		GROUPAGE				CONTAINER			
Single-phase	Three-phase	n° pumps	H (mm)	kg		n° pumps	H (mm)	kg	
				1~	3~			1~	3~
Dm 8	-	60	1310	720	-	100	2090	1190	-
Dm 10	D 10	60	1310	780	711	100	2090	1288	1174
Dm 15	D 15	45	1388	678	632	60	1804	898	837
Dm 18	-	60	1310	725	-	100	2090	1197	-
Dm 20	D 20	60	1310	797	720	100	2090	1317	1188
Dm 30	D 30	45	1388	690	647	60	1804	914	857

