



Jansen

 POMPEN- & WATERTECHNIEK

Hoogeindsestraat 5
 NL - 5447 PD Rijkevoort
 Nederland
 T : +31 (0) 485 - 371318
 F : +31 (0) 485 - 371918
 info@pompentechniek.nl
 www.pompentechniek.nl



PERFORMANCE RANGE

- Flow rate up to **2200 l/min** (132 m³/h)
- Head up to **38 m**

APPLICATION LIMITS

- Manometric suction lift up to **7 m**
- Liquid temperature between **-10 °C** and **+90 °C**
- Ambient temperature between **-10 °C** and **+40 °C**
- Max. pressure in pump body **10 bar** (PN10)
- Continuous service **S1**

CONSTRUCTION AND SAFETY STANDARDS

EN 60034-1
 IEC 60034-1
 CEI 2-3



Pump body dimensions in compliance with: **EN 733**

CERTIFICATIONS



INSTALLATION AND USE

- Water supply
- Pressure boosting
- Irrigation
- Water circulation in climatization sets
- Cleaning sets
- Firefighting sets
- Industrial applications
- Agricultural applications

Suitable for use with clean, aggressive liquids that are chemically compatible with the materials from which the pump is made. The pump should be installed in an enclosed environment, or at least sheltered from inclement weather.

OPTIONALS AVAILABLE ON REQUEST

- Special mechanical seal
- Other voltages or 60 Hz frequency
- Compatibility with hotter or colder liquids
- Compatibility with hotter or colder ambients

GUARANTEE

2 years subject to terms and conditions

PERFORMANCE RANGE

50 Hz n= 2900 1/min HS= 0 m

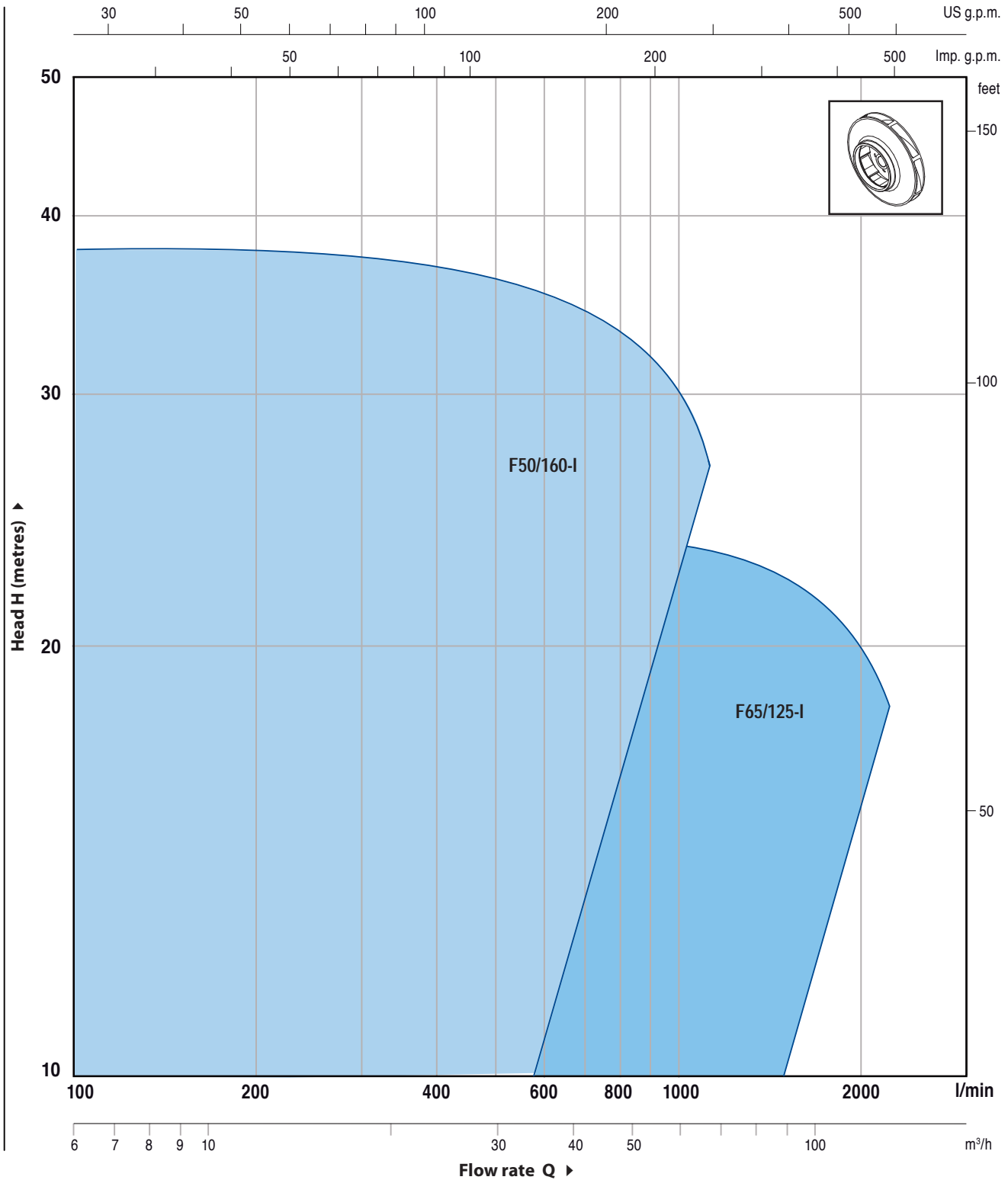

F50/160-I

CHARACTERISTIC CURVES AND PERFORMANCE DATA

50 Hz n= 2900 1/min HS= 0 m

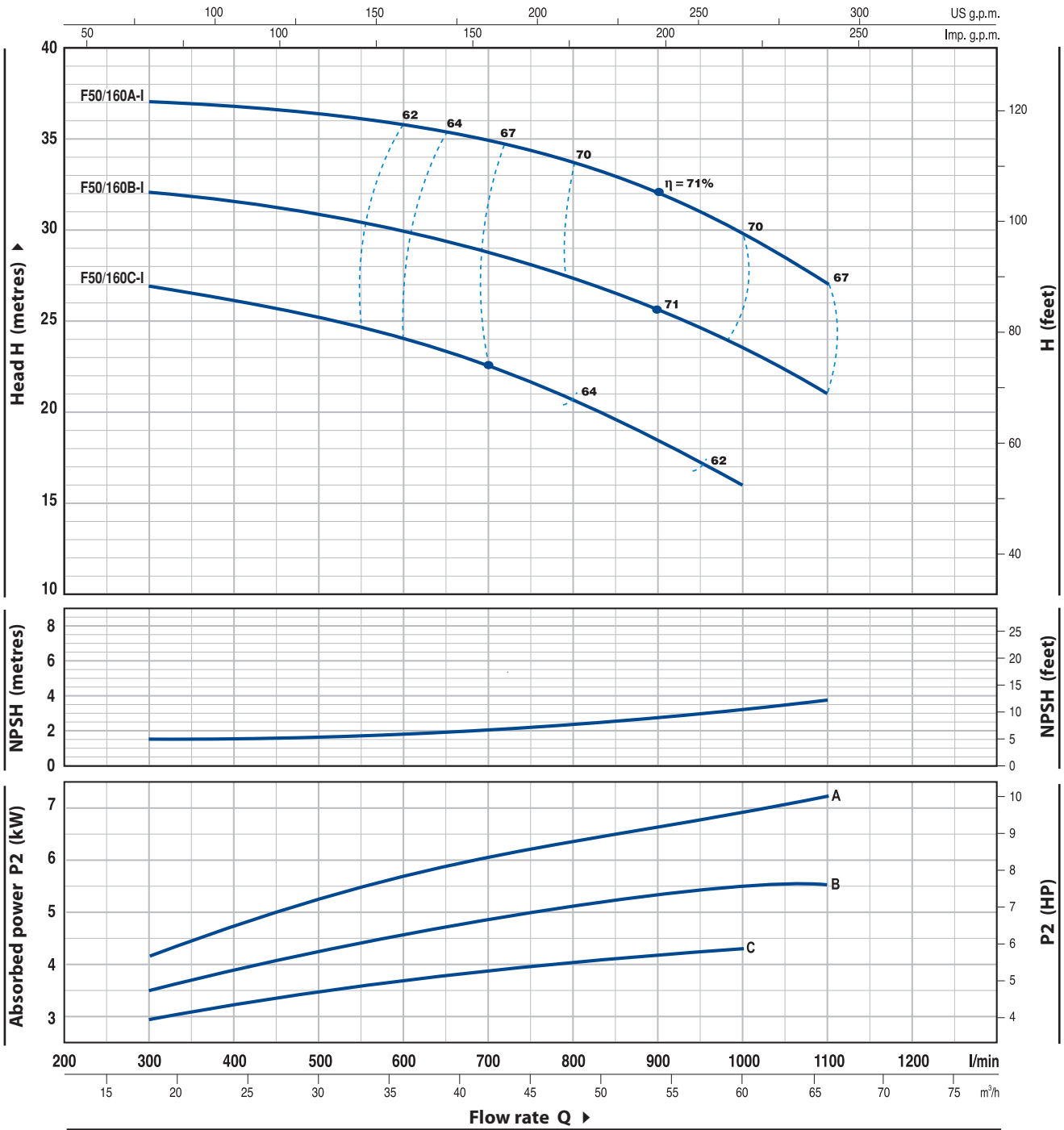

MODEL	POWER		Q	0	18	24	30	36	42	48	54	60	66
	kW	HP		0	300	400	500	600	700	800	900	1000	1100
Three-phase			l/min										
F 50/160C-I	4	5.5	H metres	27	27	26.5	25	24.5	23	20	18.5	16	
F 50/160B-I	5.5	7.5		33	32	31.7	31	30	29	27	26	24	21
F 50/160A-I	7.5	10		38	37	36.8	36.5	36	34	33	32	30	27

Q = Flow rate H = Total manometric head HS = Suction height

Tolerance of characteristic curves in compliance with EN ISO 9906 App. A.

CHARACTERISTIC CURVES AND PERFORMANCE DATA

50 Hz n= 2900 1/min HS= 0 m

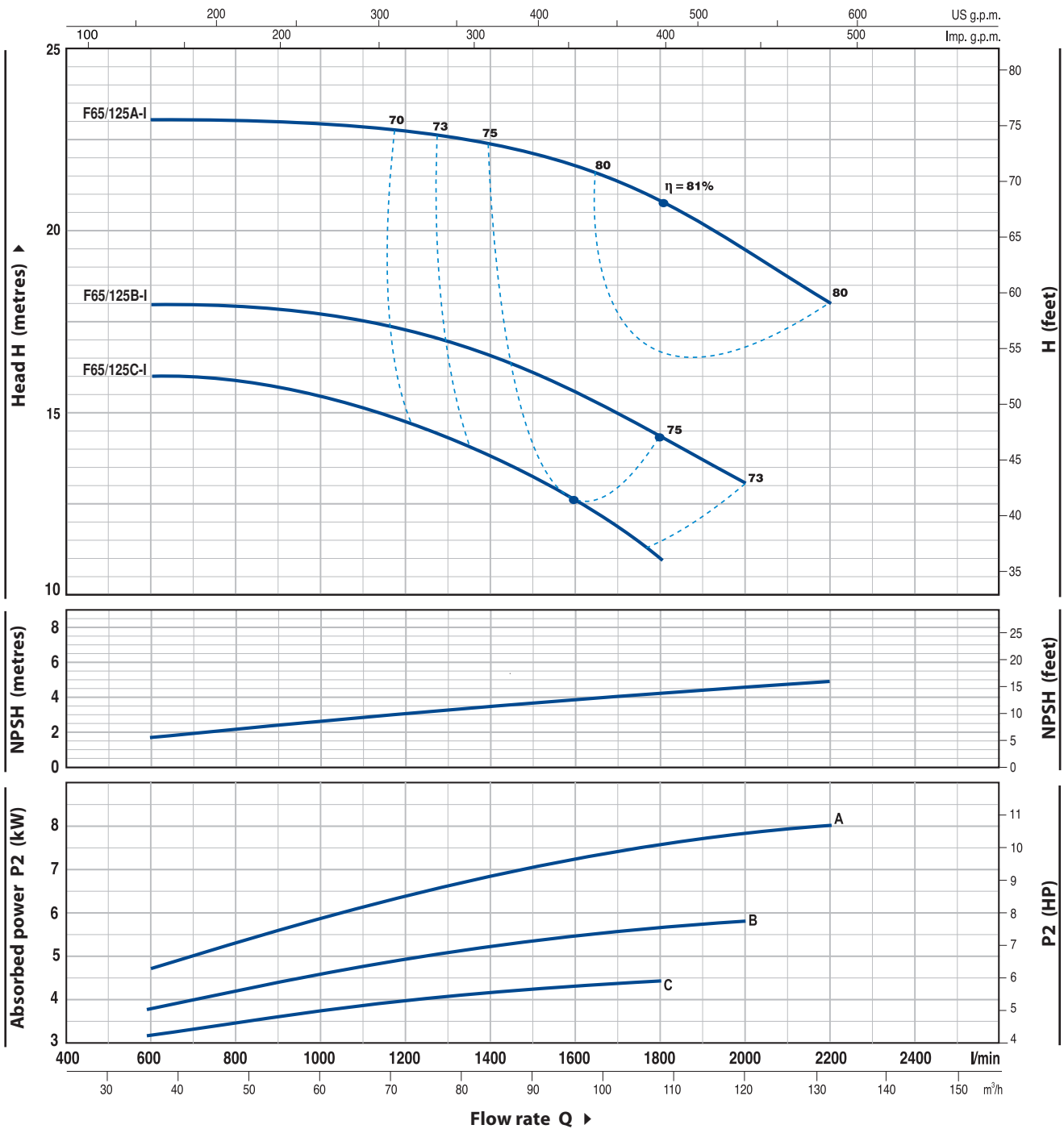

MODEL	POWER		Q	Flow rate												
	kW	HP		m³/h	0	36	48	60	72	84	96	108	120	132		
Three-phase			l/min	0	600	800	1000	1200	1400	1600	1800	2000	2200			
F 65/125C-I	4	5.5	H metres	16	16	16	15.5	14.5	13.5	12.5	11					
F 65/125B-I	5.5	7.5		18	18	18	18	17	16.5	15.5	14.5	13				
F 65/125A-I	7.5	10		23	23	23	23	22.5	22.5	22	21	19.5	18			

Q = Flow rate H = Total manometric head HS = Suction height

Tolerance of characteristic curves in compliance with EN ISO 9906 App. A.

POS.	COMPONENT	CONSTRUCTION CHARACTERISTICS					
1	PUMP BODY	Stainless steel AISI 316, complete with flanged suction and delivery ports					
2	BODY BACKPLATE	Stainless steel AISI 316					
4	IMPELLER	Stainless steel AISI 316					
5	MOTOR SHAFT	Stainless steel AISI 316					
6	MECHANICAL SEAL	<i>Pump</i>	<i>Seal</i>	<i>Shaft</i>	<i>Materials</i>		
		<i>Model</i>	<i>Model</i>	<i>Diameter</i>	<i>Stationary ring</i>	<i>Rotational ring</i>	<i>Elastomer</i>
		F50/160-I F65/125-I	FN-24SV	Ø 24 mm	Silicon carbide	Silicon carbide	Viton
7	BEARINGS	<i>Pump</i>	<i>Model</i>				
		F50/160-I F65/125-I	6307 ZZ - C3 / 6206 ZZ - C3				
9	ELECTRIC MOTOR	F: three-phase 230/400 V - 50 Hz for 4 kW. 400/690 V - 50 Hz from 5.5 to 7.5 kW. ⇒ Pumps fitted with the three-phase motor option offer IE2 (IEC 60034-30) class high performance – Insulation: F class. – Protection: IP 55.					

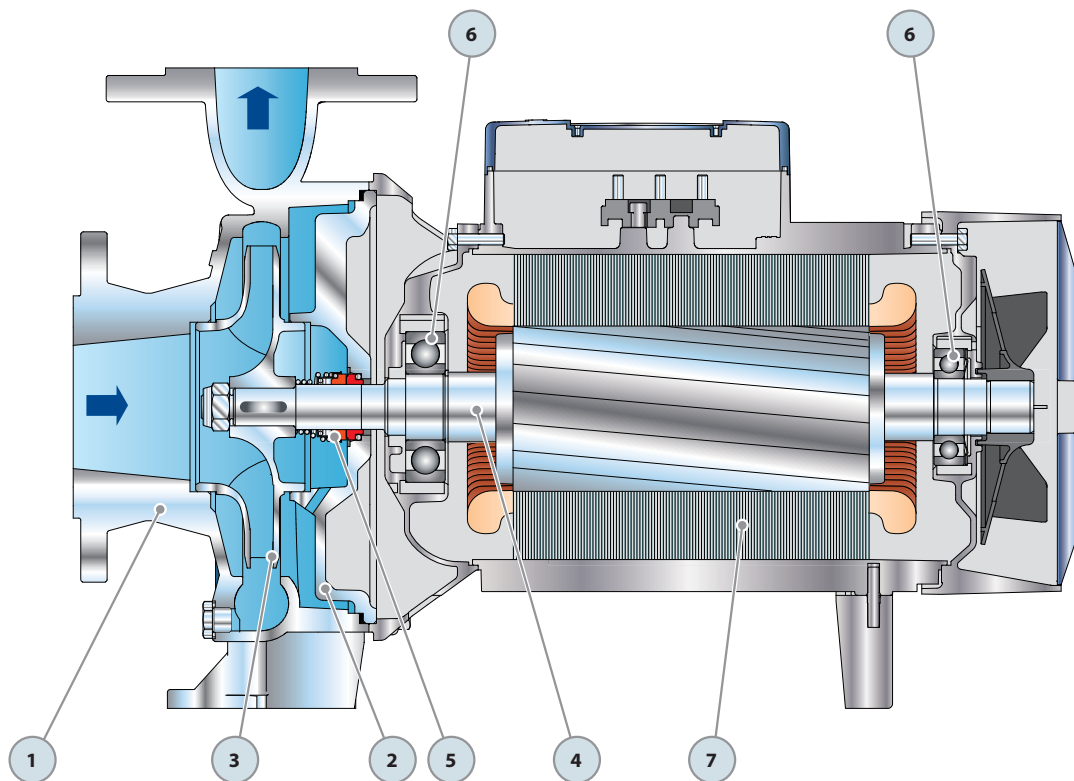

DIMENSIONS AND WEIGHT

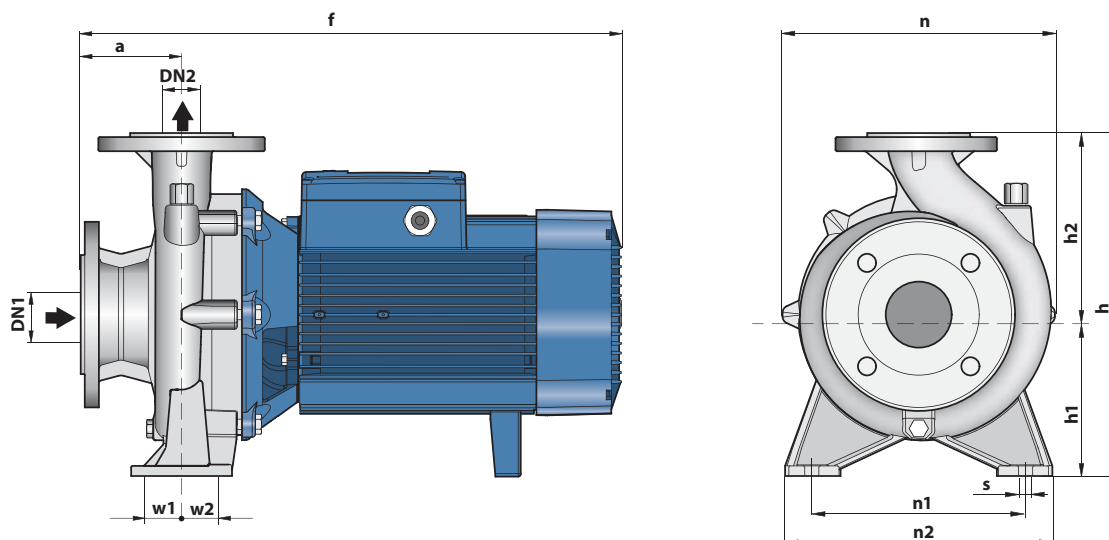

MODEL	PORTS		DIMENSIONS mm											kg 3~
	DN1	DN2	a	f	h	h1	h2	n	n1	n2	w1	w2	s	
Three-phase														
F 50/160C-I	65	50	100	489	340	160	180	269	212	265	35	35	14	50.2
F 50/160B-I				535										54.0
F 50/160A-I				511										65.5
F 65/125C-I	80	65	100	557	340	160	180	291	212	280	47.5	47.5	14	62.6
F 65/125B-I				557										67.7
F 65/125A-I				557										72.9

ABSORPTION

MODEL	VOLTAGE (three-phase)		
	230÷240 V	400÷415 V	690÷720 V
Three-phase			
F 50/160C-I	15.8 A	9.1 A	5.3 A
F 50/160B-I	-	12.3 A	7.1 A
F 50/160A-I	-	15.5 A	8.9 A
F 65/125C-I	17.5 A	10.0 A	5.8 A
F 65/125B-I	-	12.0 A	7.0 A
F 65/125A-I	-	16.5 A	9.5 A

PALLETIZATION

MODEL	GROUPAGE			CONTAINER		
	n° pumps	H (mm)	kg 3~	n° pumps	H (mm)	kg 3~
Three-phase						
F 50/160C-I	12	1535	619	16	2000	820
F 50/160B-I	12	1535	665	16	2000	881
F 50/160A-I	12	1535	802	16	2000	1064
F 65/125C-I	12	1535	768	16	2000	1018
F 65/125B-I	12	1535	829	16	2000	1100
F 65/125A-I	12	1535	891	16	2000	1183

