



Hoogeindsestraat 5
 NL - 5447 PD Rijkevoort
 Nederland
 T : +31 (0) 485 - 371318
 F : +31 (0) 485 - 371918
 info@pompentechniek.nl
 www.pompentechniek.nl



PERFORMANCE RANGE

- Flow rate up to **6000 l/min** (360 m³/h)
- Head up to **95 m**

APPLICATION LIMITS

- Manometric suction lift up to **7 m**
- Liquid temperature between **-10 °C** and **+90 °C**
- Ambient temperature between **-10 °C** and **+40 °C**
- Max. pressure in pump body **10 bar** (PN10)
- Continuous service **S1**

CONSTRUCTION AND SAFETY STANDARDS

EN 60034-1
 IEC 60034-1
 CEI 2-3



Pump body dimensions in compliance with **EN 733**

CERTIFICATIONS



INSTALLATION AND USE

- Water supply
- Pressure boosting
- Irrigation
- Water circulation in climatisation sets
- Cleaning sets
- Firefighting sets
- Industrial applications
- Agricultural applications

The pumps must be installed in enclosed places, or at least protected against inclement weather.

OPTIONALS AVAILABLE ON REQUEST

- Special mechanical seal
- Other voltages or 60 Hz frequency
- Compatibility with hotter or colder liquids
- Compatibility with hotter or colder ambients

GUARANTEE

1 year subject to terms and conditions

PERFORMANCE RANGE

50 Hz n= 2900 1/min HS= 0 m

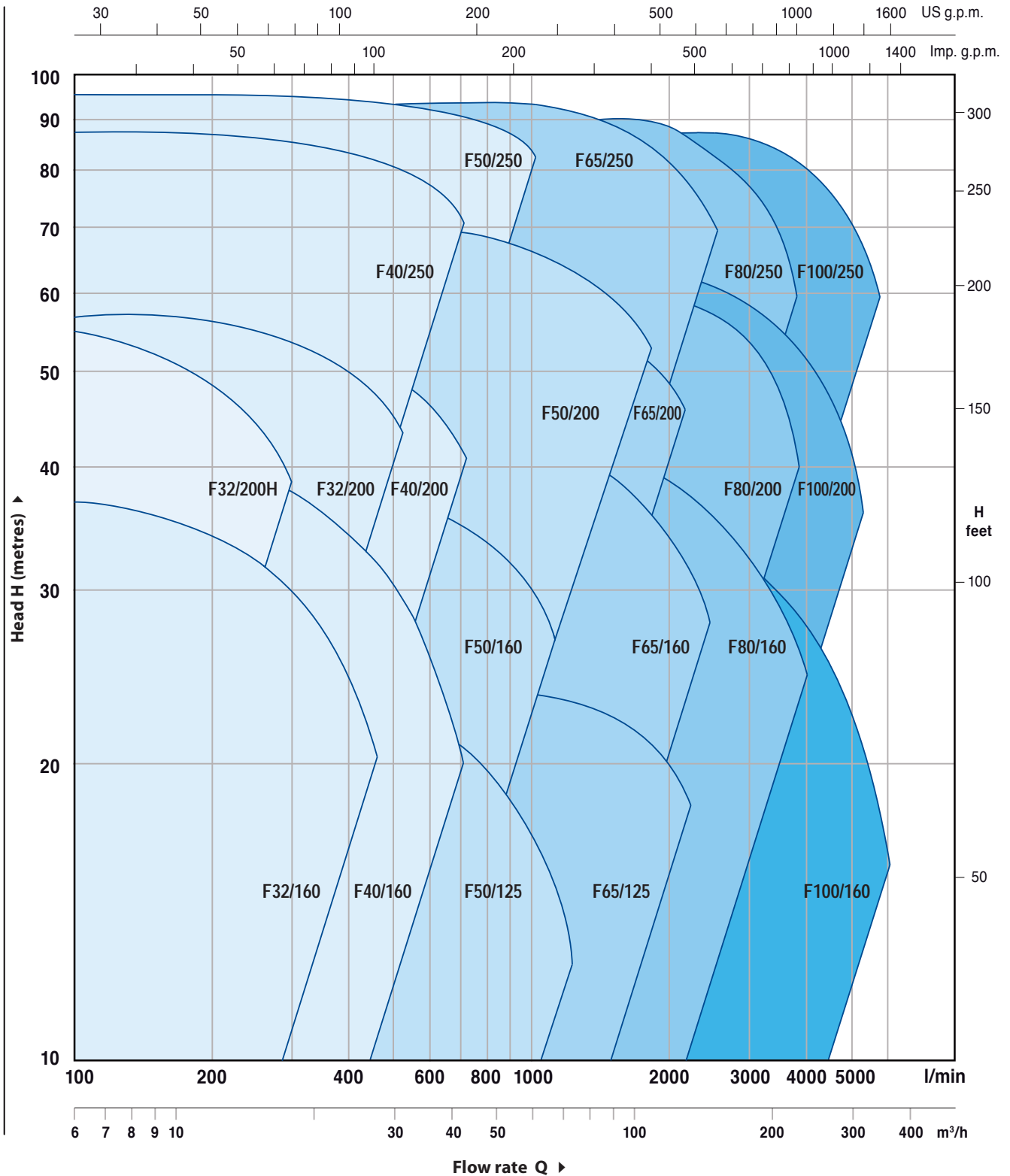

F32/160

CHARACTERISTIC CURVES AND PERFORMANCE DATA

50 Hz n= 2900 1/min HS= 0 m

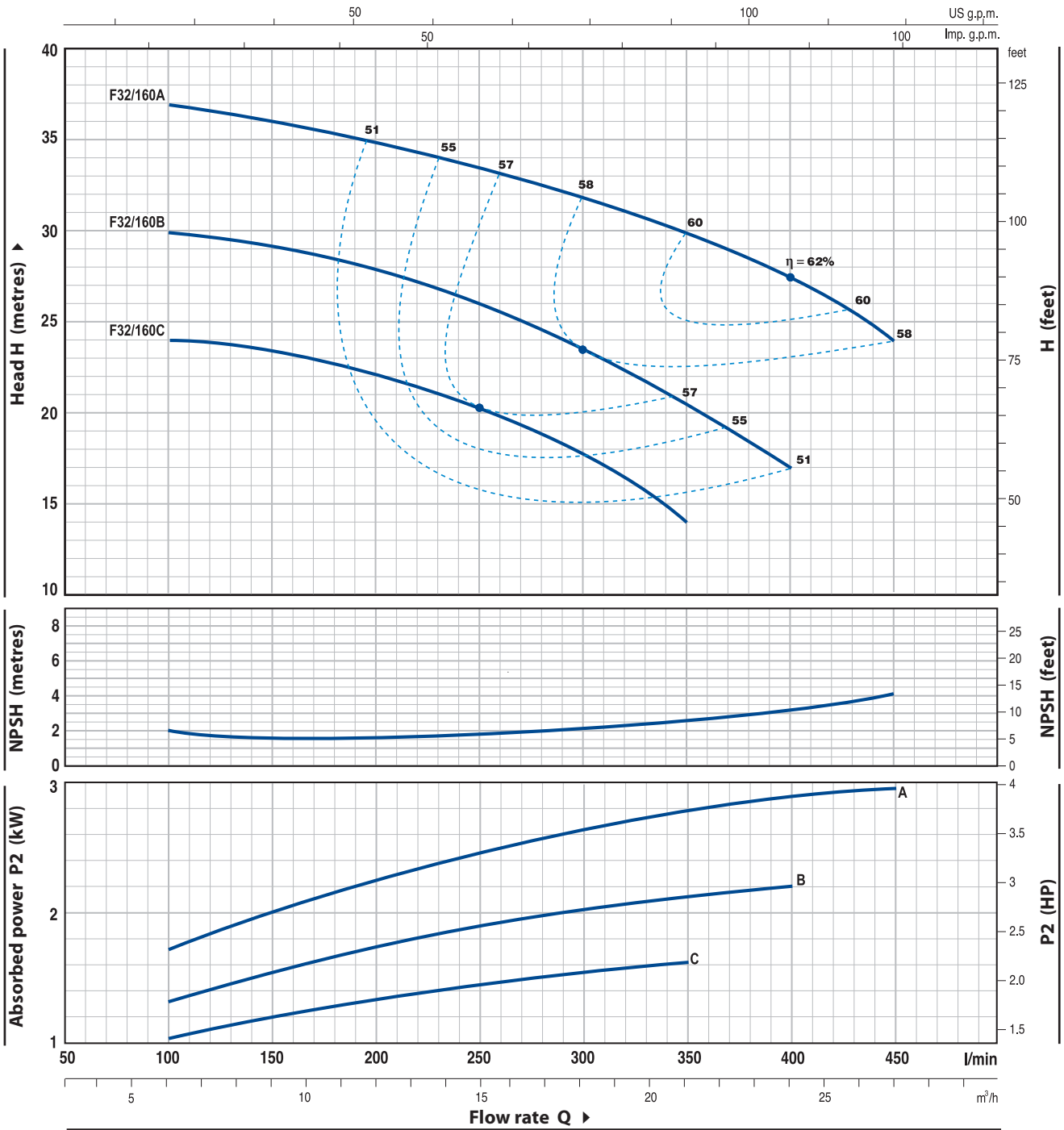

MODEL		POWER		Q	0	6	9	12	15	18	21	24	27
Single-phase	Three-phase	kW	HP		0	100	150	200	250	300	350	400	450
Fm 32/160C	F 32/160C	1.5	2	H metres	25	24	23.5	22	20.5	18	14		
Fm 32/160B	F 32/160B	2.2	3		31	30	29	28	26	23.5	20.5	17	
-	F 32/160A	3	4		38	37	36	35	33.5	31.5	30	27.5	24

Q = Flow rate H = Total manometric head HS = Suction height

Tolerance of characteristic curves in compliance with EN ISO 9906 App. A.

CHARACTERISTIC CURVES AND PERFORMANCE DATA

50 Hz n= 2900 1/min HS= 0 m

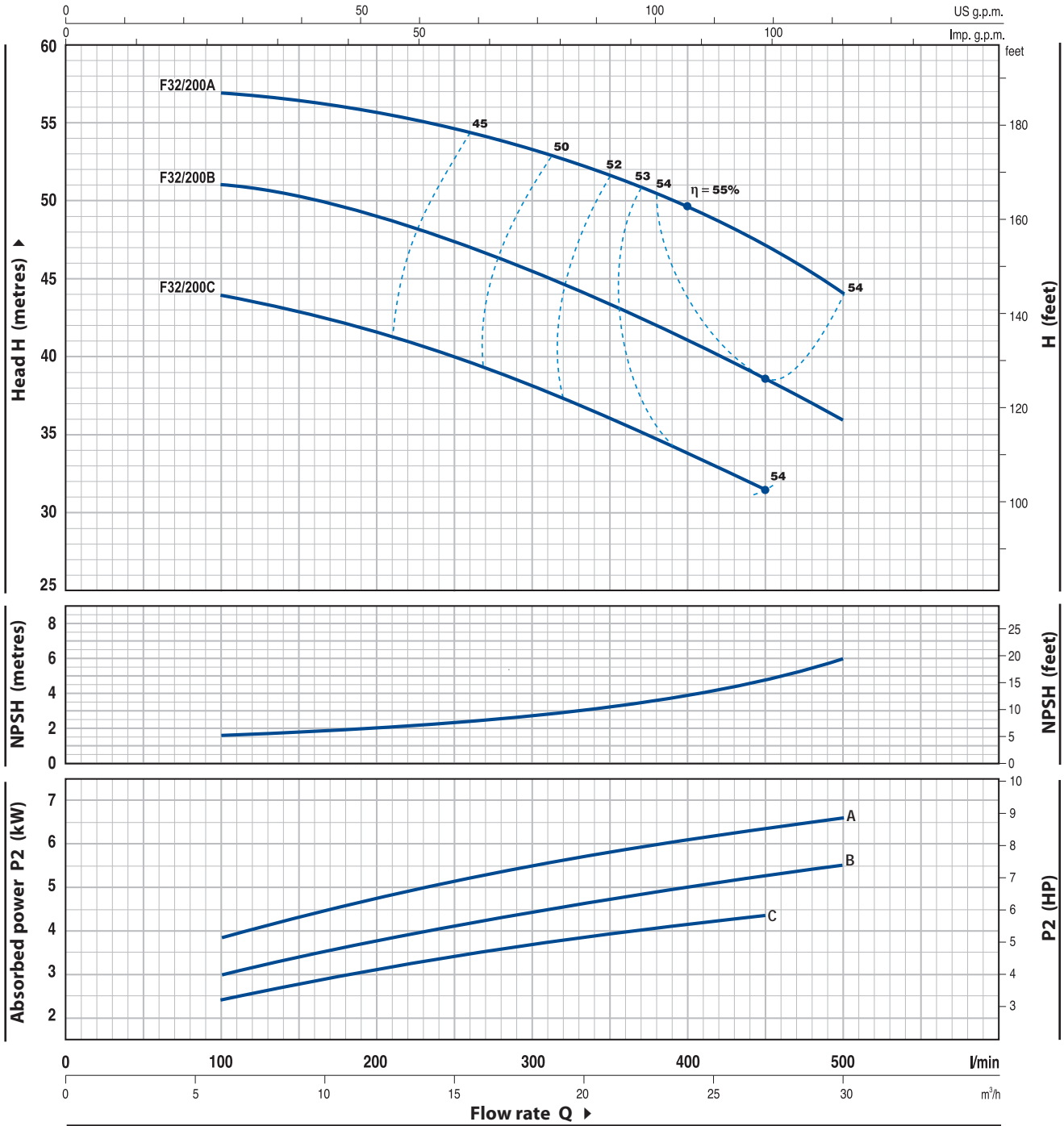

MODEL	POWER		Q	0	6	9	12	15	18	21	24	27	30
	kW	HP		0	100	150	200	250	300	350	400	450	500
Three-phase			H metres	46	44	43	41.5	40	38	36	34	31.5	
F 32/200C	4	5.5		52	51	50.5	49	47	45	43	41	38.5	36
F 32/200B	5.5	7.5		60	57	56.5	56	55	53.5	52	50	47	44

Q = Flow rate H = Total manometric head HS = Suction height

Tolerance of characteristic curves in compliance with EN ISO 9906 App. A.

F32/200H

CHARACTERISTIC CURVES AND PERFORMANCE DATA

50 Hz n= 2900 1/min HS= 0 m

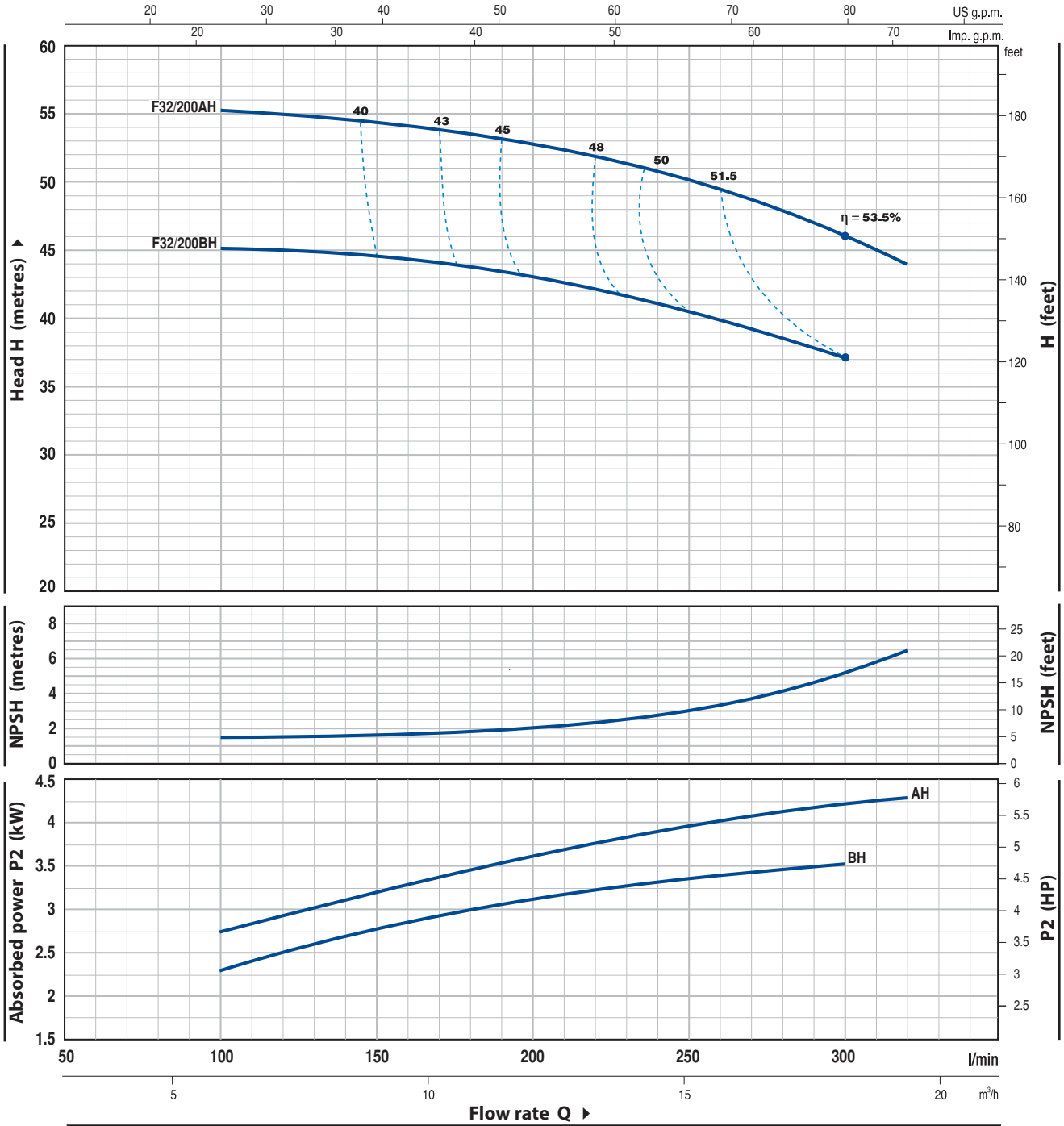

MODEL	POWER		Q	Flow rate						
	kW	HP		m ³ /h	l/min	l/min	l/min	l/min	l/min	l/min
Three-phase				0	6	9	12	15	18	19.2
F 32/200BH	3	4	H metres	47	45	44.5	43	40.5	37	
F 32/200AH	4	5.5	H metres	57	55	54	52.5	50	46	44

Q = Flow rate H = Total manometric head HS = Suction height

Tolerance of characteristic curves in compliance with EN ISO 9906 App. A.

CHARACTERISTIC CURVES AND PERFORMANCE DATA

50 Hz n= 2900 1/min HS= 0 m

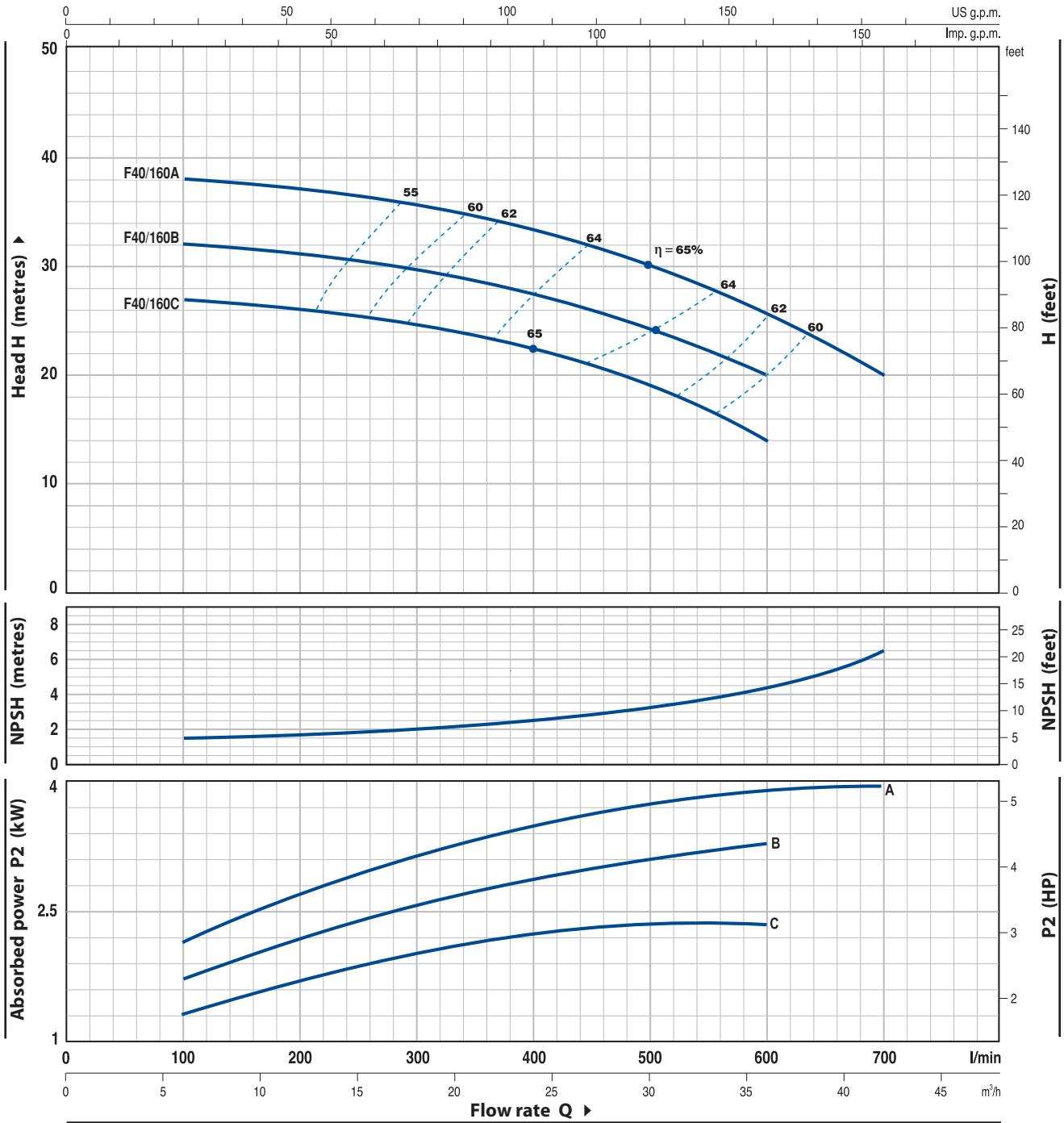

MODEL		POWER		Q	Flow rate												
Single-phase	Three-phase	kW	HP		m ³ /h	0	6	9	12	15	18	24	30	36	42		
Fm 40/160C	F 40/160C	2.2	3	H metres	0	100	150	200	250	300	400	500	600	700			
-	F 40/160B	3	4		27	27	26.5	26	25.5	25	22.5	19	14				
-	F 40/160A	4	5.5		32	32	31.5	31	30.5	30	27.5	24	20				
					38	38	37.8	37	36.5	36	33.5	30	26	20			

Q = Flow rate H = Total manometric head HS = Suction height

Tolerance of characteristic curves in compliance with EN ISO 9906 App. A.

F40/200

CHARACTERISTIC CURVES AND PERFORMANCE DATA

50 Hz n= 2900 1/min HS= 0 m

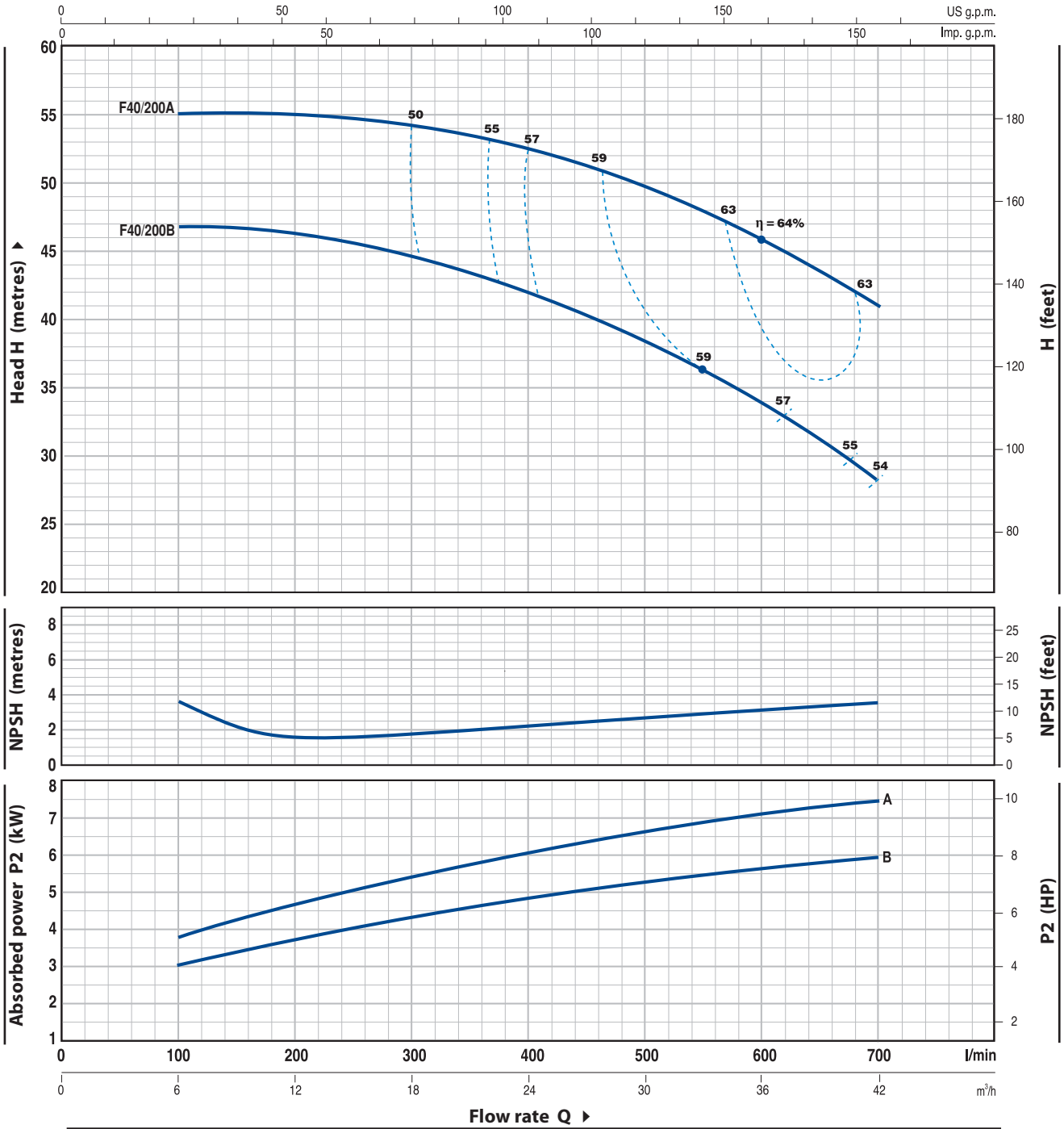

MODEL	POWER		Q	Flow rate												
	kW	HP		0	6	9	12	15	18	24	30	36	42			
Three-phase				0	100	150	200	250	300	400	500	600	700			
F 40/200B	5.5	7.5	H metres	48	47	46.5	46	45.5	44.5	42	38	34	28			
F 40/200A	7.5	10	H metres	56	55	55	55	54.5	54	52.5	49.5	46	41			

Q = Flow rate H = Total manometric head HS = Suction height

Tolerance of characteristic curves in compliance with EN ISO 9906 App. A.

CHARACTERISTIC CURVES AND PERFORMANCE DATA

50 Hz n= 2900 1/min HS= 0 m

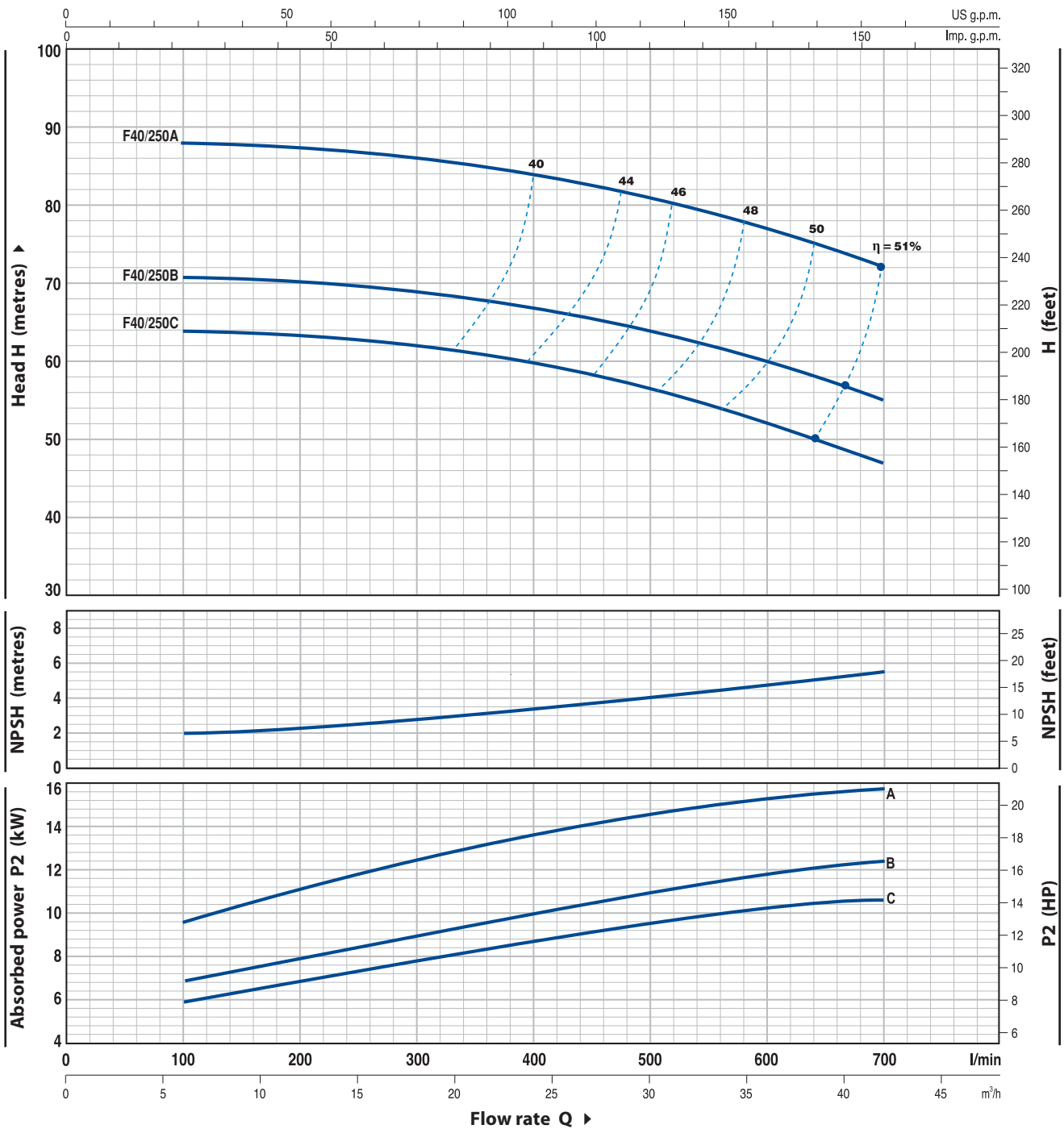

MODEL	POWER		Q	Flow rate												
	kW	HP		0	6	9	12	15	18	24	30	36	42			
Three-phase			l/min	0	100	150	200	250	300	400	500	600	700			
F 40/250C	9.2	12.5	H metres	64	64	63.5	63	62.5	62	60	56.5	52.5	47			
F 40/250B	11	15		71	71	70.5	70	69.5	69	67	64	60	55			
F 40/250A	15	20		88	88	87.5	87	86.5	86	84	81	77	72			

Q = Flow rate H = Total manometric head HS = Suction height

Tolerance of characteristic curves in compliance with EN ISO 9906 App. A.

F50/125

CHARACTERISTIC CURVES AND PERFORMANCE DATA

50 Hz n= 2900 1/min HS= 0 m

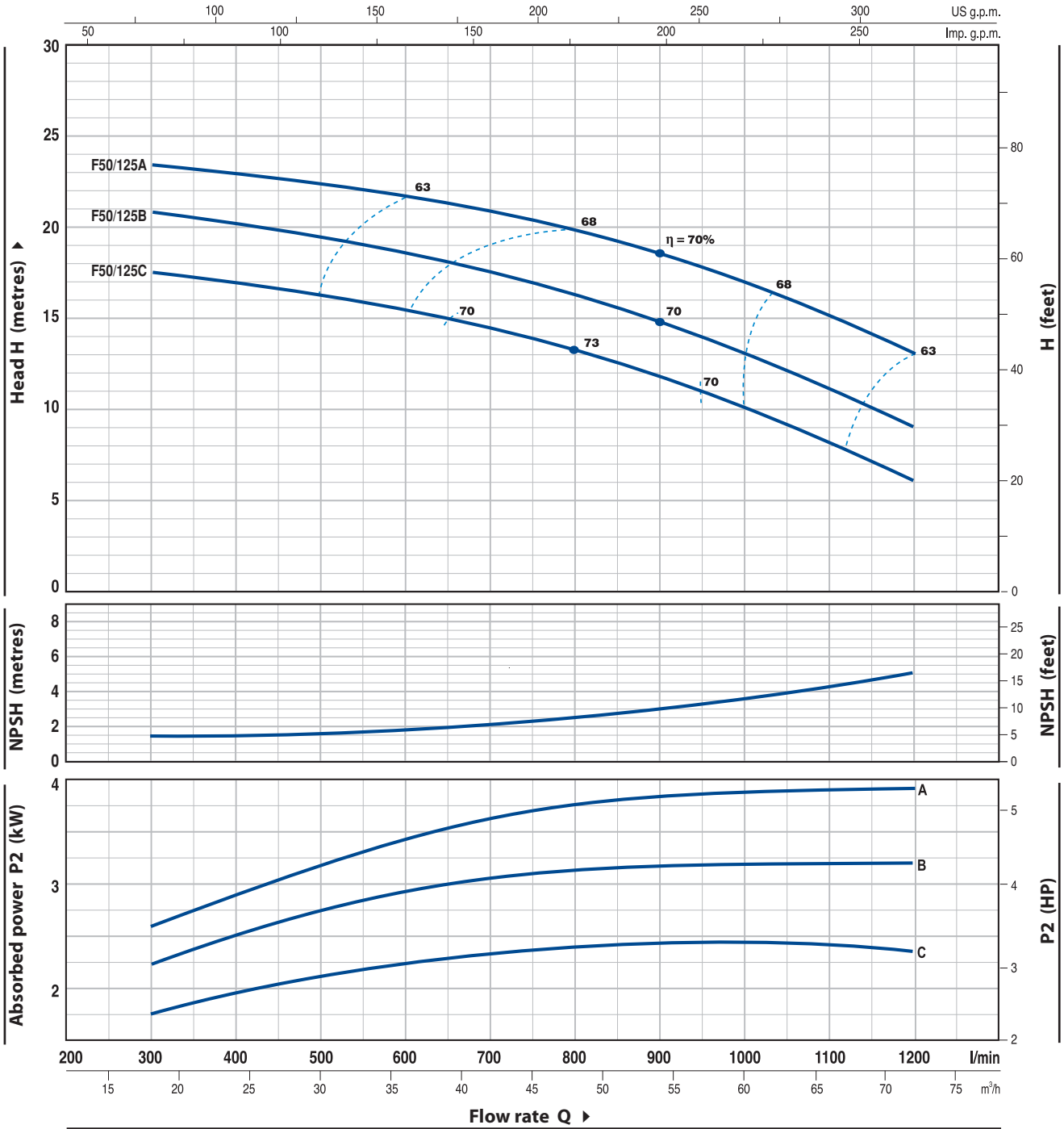

MODEL		POWER		Q	Flow rate													
Single-phase	Three-phase	kW	HP		0	18	24	30	36	42	48	54	60	66	72			
Fm 50/125C	F 50/125C	2.2	3	H metres	18.5	17.5	17	16.5	15.5	14.8	13.5	12	10.5	8.2	6			
-	F 50/125B	3	4		21.5	20.7	20	19.5	18.8	17.8	16.5	15	13.5	11.2	9			
-	F 50/125A	4	5.5		24.5	23.5	23	22.5	21.8	20.8	19.5	18.3	16.8	15	13			

Q = Flow rate H = Total manometric head HS = Suction height

Tolerance of characteristic curves in compliance with EN ISO 9906 App. A.

CHARACTERISTIC CURVES AND PERFORMANCE DATA

50 Hz n= 2900 1/min HS= 0 m

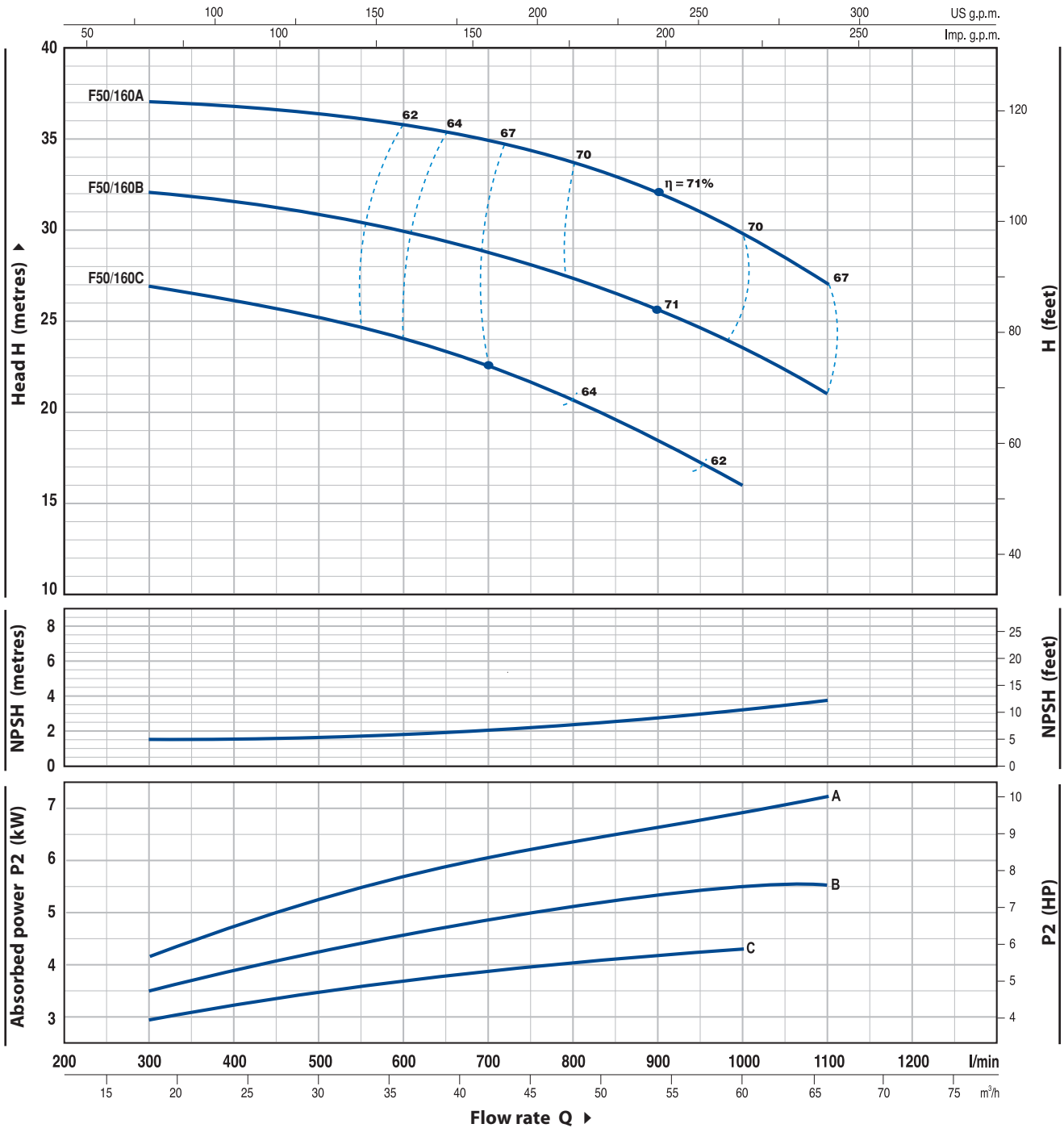

MODEL	POWER		Q	0	18	24	30	36	42	48	54	60	66
	kW	HP		0	300	400	500	600	700	800	900	1000	1100
F 50/160C	4	5.5	H metres	27	27	26.5	25	24.5	23	20	18.5	16	
F 50/160B	5.5	7.5		33	32	31.7	31	30	29	27	26	24	21
F 50/160A	7.5	10		38	37	36.8	36.5	36	34	33	32	30	27

Q = Flow rate H = Total manometric head HS = Suction height

Tolerance of characteristic curves in compliance with EN ISO 9906 App. A.

F50/200

CHARACTERISTIC CURVES AND PERFORMANCE DATA

50 Hz n= 2900 1/min HS= 0 m

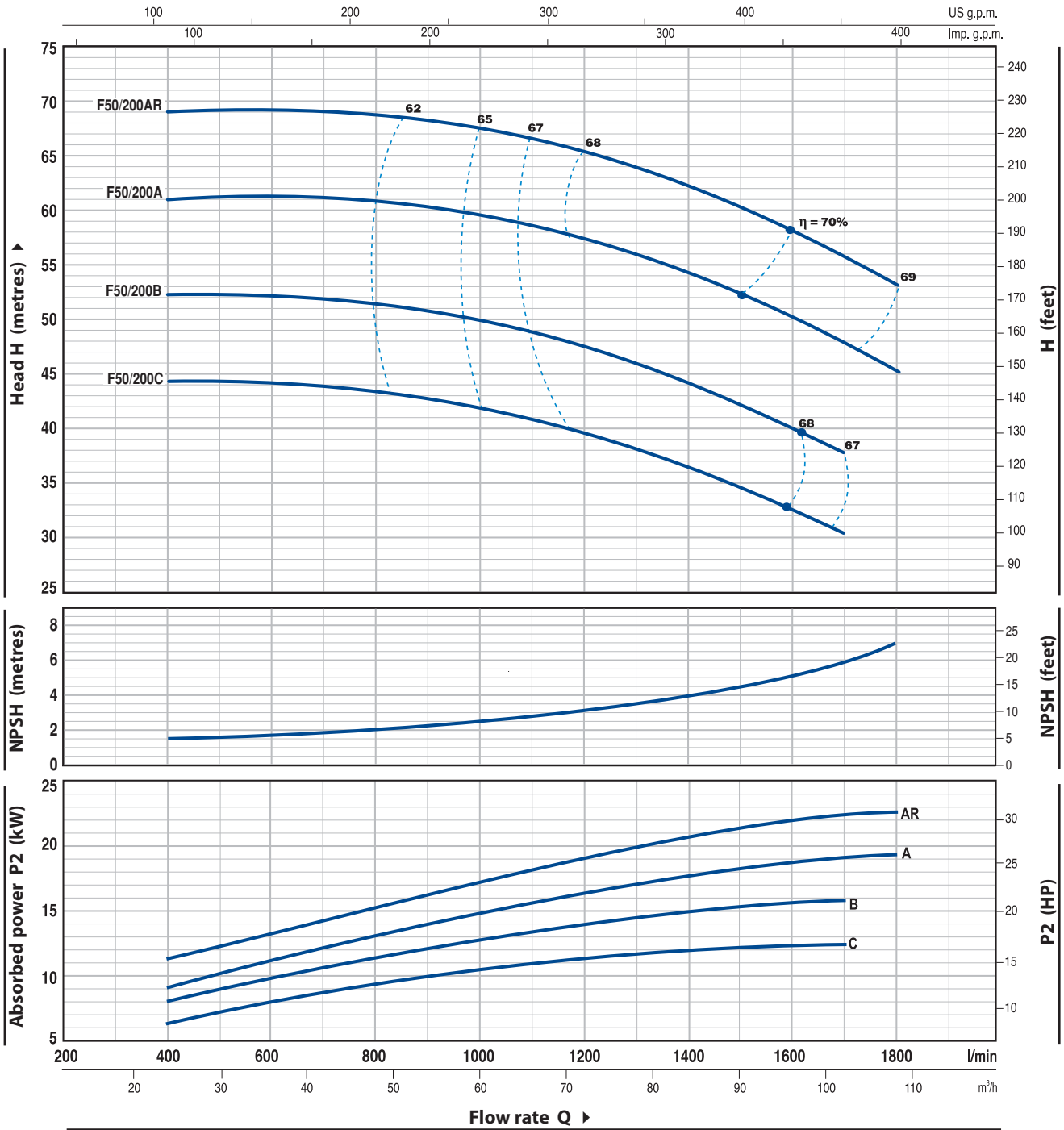

MODEL	POWER		Q	H metres											
	kW	HP		m ³ /h	24	36	48	60	72	84	96	102	108		
Three-phase			l/min	400	600	800	1000	1200	1400	1600	1700	1800			
F 50/200C	11	15		44	44	44	42	39	36	33	30				
F 50/200B	15	20		52	52	52	50	47	44	40	38				
F 50/200A	18.5	25		61	61	60.5	60	57	54	50	48	45			
F 50/200AR	22	30		69	69	68.5	68	65	62	58	56	53			

Q = Flow rate H = Total manometric head HS = Suction height

Tolerance of characteristic curves in compliance with EN ISO 9906 App. A.

CHARACTERISTIC CURVES AND PERFORMANCE DATA

50 Hz n= 2900 1/min HS= 0 m

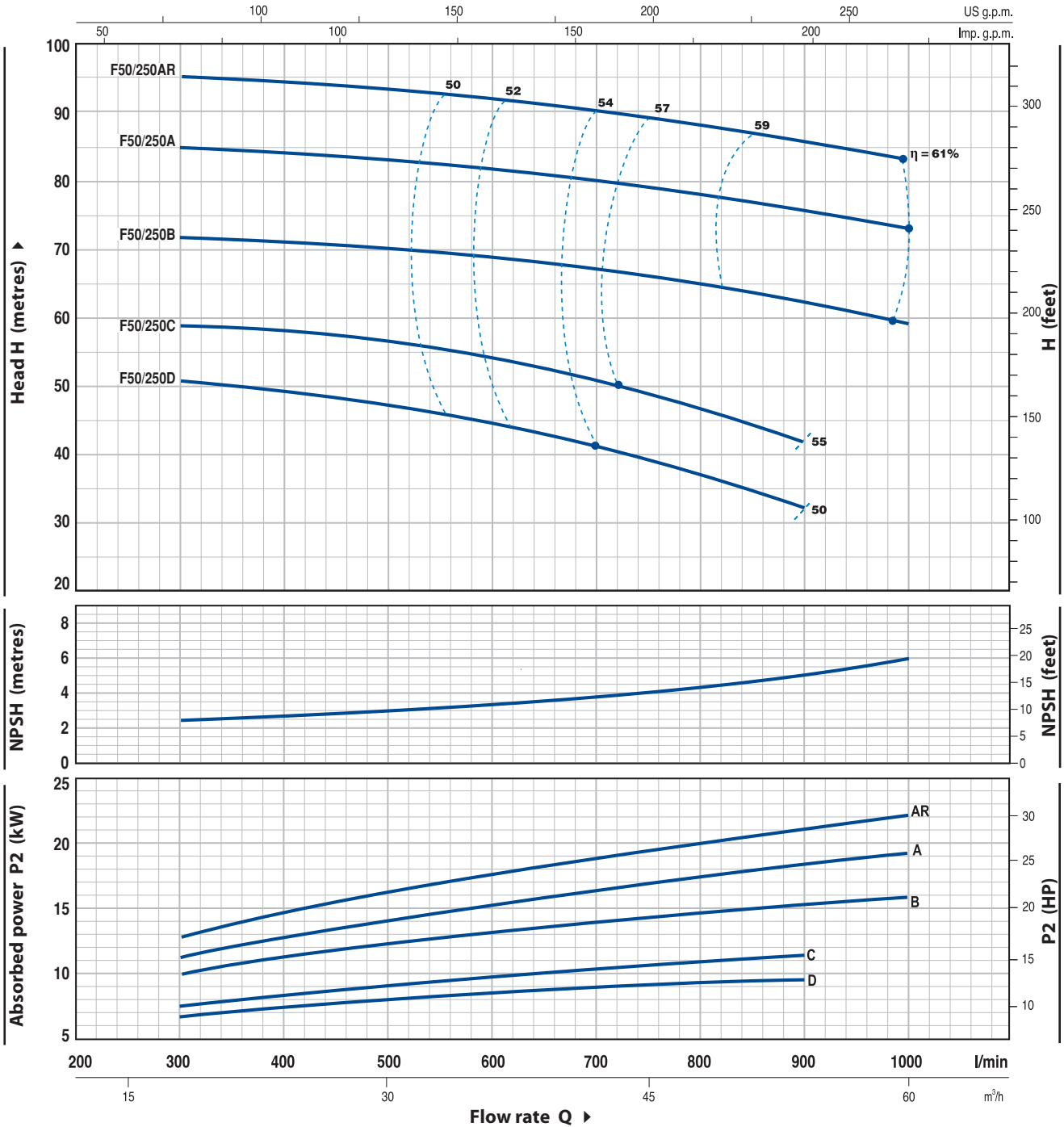

MODEL	POWER		Q	0	18	24	30	36	42	48	54	60
	kW	HP		0	300	400	500	600	700	800	900	1000
Three-phase			l/min									
F 50/250D	9.2	12.5	H metres	51	51	49	47	44	41	37	32	
F 50/250C	11	15		59	59	58	57	54	51	47	42	
F 50/250B	15	20		72	72	71	70	69	67	65	62	59
F 50/250A	18.5	25		85	85	84	83	82	80	78	76	73
F 50/250AR	22	30		95	95	94	93	92	90	88	86	83

Q = Flow rate H = Total manometric head HS = Suction height

Tolerance of characteristic curves in compliance with EN ISO 9906 App. A.

F65/125

CHARACTERISTIC CURVES AND PERFORMANCE DATA

50 Hz n= 2900 1/min HS= 0 m

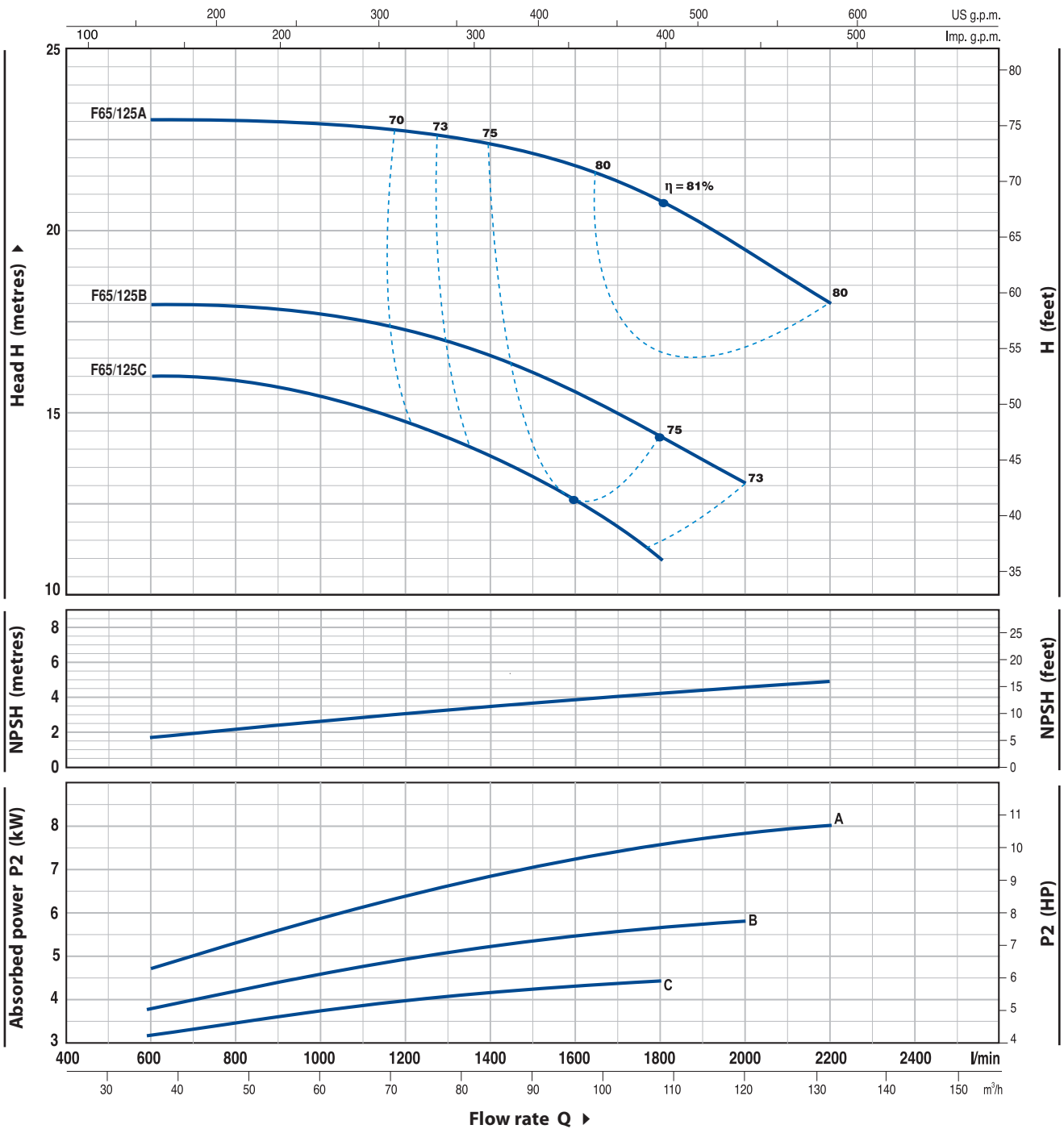

MODEL	POWER		Q	Flow rate												
	kW	HP		m ³ /h	0	36	48	60	72	84	96	108	120	132		
Three-phase			l/min	0	600	800	1000	1200	1400	1600	1800	2000	2200			
F 65/125C	4	5.5	H metres	16	16	16	15.5	14.5	13.5	12.5	11					
F 65/125B	5.5	7.5		18	18	18	18	17	16.5	15.5	14.5	13				
F 65/125A	7.5	10		23	23	23	23	22.5	22.5	22	21	19.5	18			

Q = Flow rate H = Total manometric head HS = Suction height

Tolerance of characteristic curves in compliance with EN ISO 9906 App. A.

CHARACTERISTIC CURVES AND PERFORMANCE DATA

50 Hz n= 2900 1/min HS= 0 m

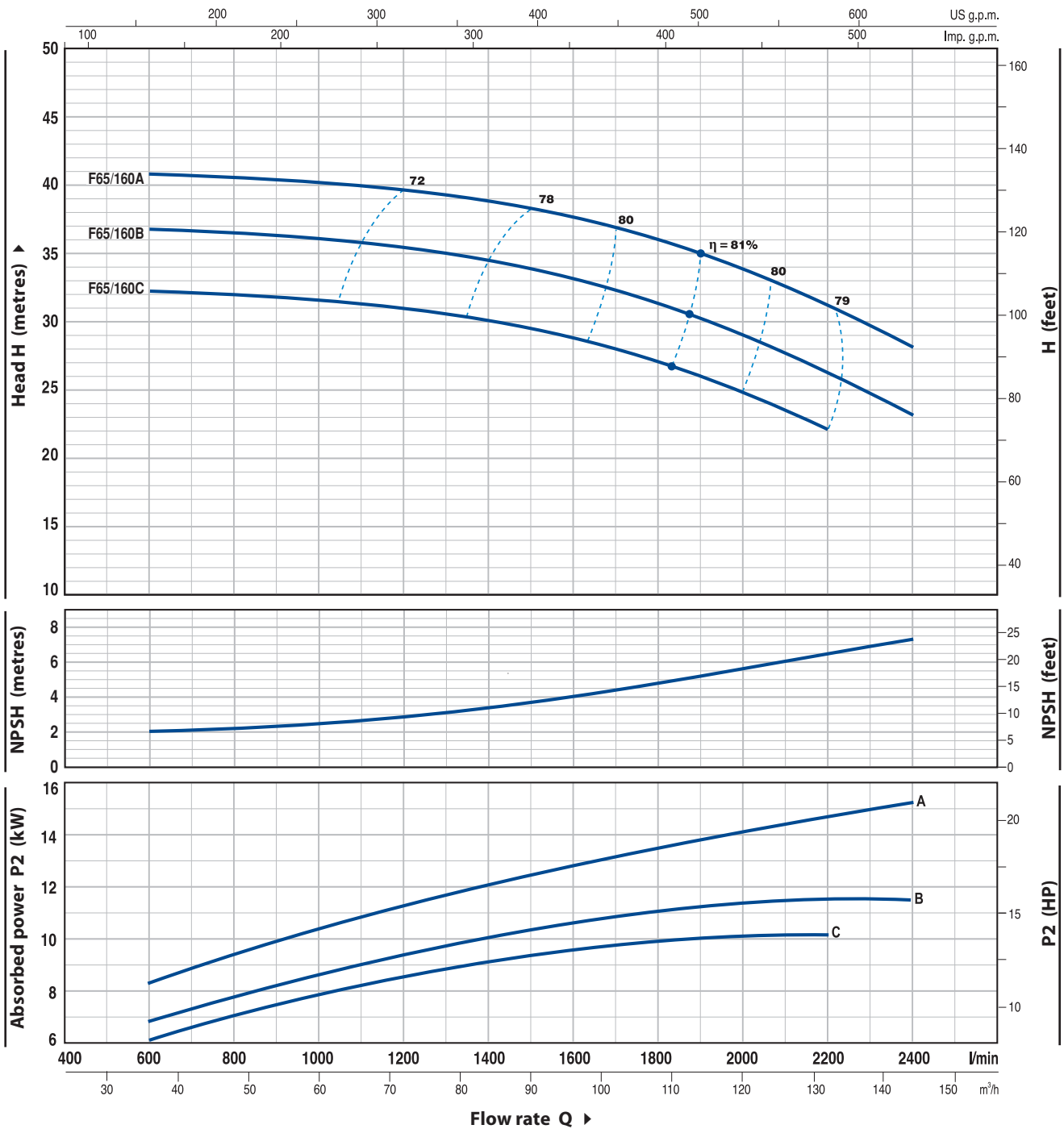

MODEL	POWER		Q	Flow rate													
	kW	HP		m ³ /h	0	36	48	60	72	84	96	108	120	132	144		
Three-phase			l/min	0	600	800	1000	1200	1400	1600	1800	2000	2200	2400			
F 65/160C	9.2	12.5	H metres	32	32	32	32	32	30	29	27	25	22				
F 65/160B	11	15		37	36.5	36.5	36	35.5	34	33	31	29	26	23			
F 65/160A	15	20		41	40.5	40.5	40	39.5	39	37.5	36	34	31	28			

Q = Flow rate H = Total manometric head HS = Suction height

Tolerance of characteristic curves in compliance with EN ISO 9906 App. A.

F65/200

CHARACTERISTIC CURVES AND PERFORMANCE DATA

50 Hz n= 2900 1/min HS= 0 m

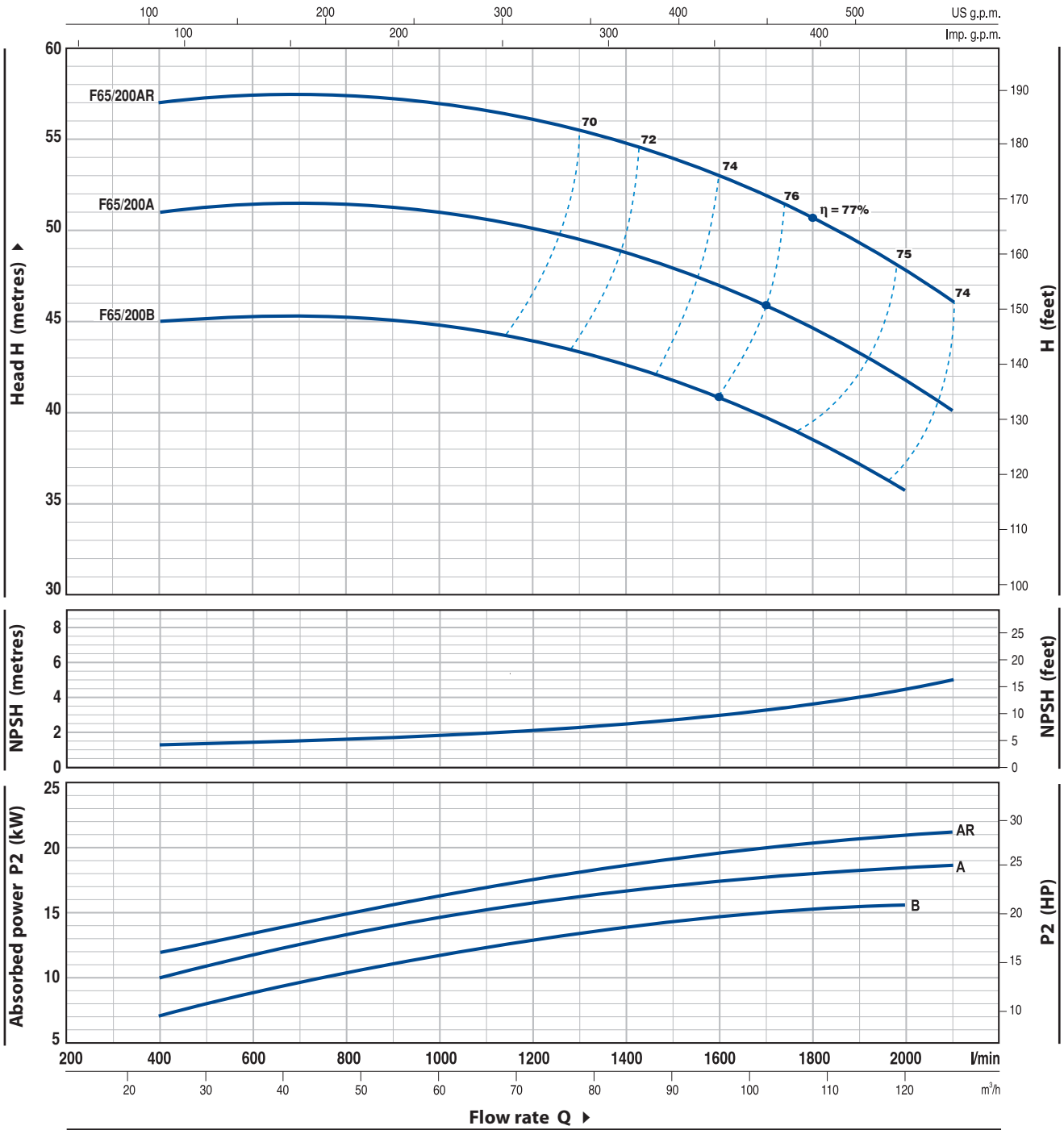

MODEL	POWER		Q	24	36	48	60	72	84	96	108	120	126
	kW	HP		m³/h	400	600	800	1000	1200	1400	1600	1800	2000
Three-phase			l/min										
F 65/200B	15	20	H metres	45	45	45	45	44	42.5	41	38.5	35.5	
F 65/200A	18.5	25		51	51	51	51	50	49	47	44.5	41.5	40
F 65/200AR	22	30		57	57	57	57	56	55	53	50.5	47.5	46

Q = Flow rate H = Total manometric head HS = Suction height

Tolerance of characteristic curves in compliance with EN ISO 9906 App. A.

CHARACTERISTIC CURVES AND PERFORMANCE DATA

50 Hz n= 2900 1/min HS= 0 m

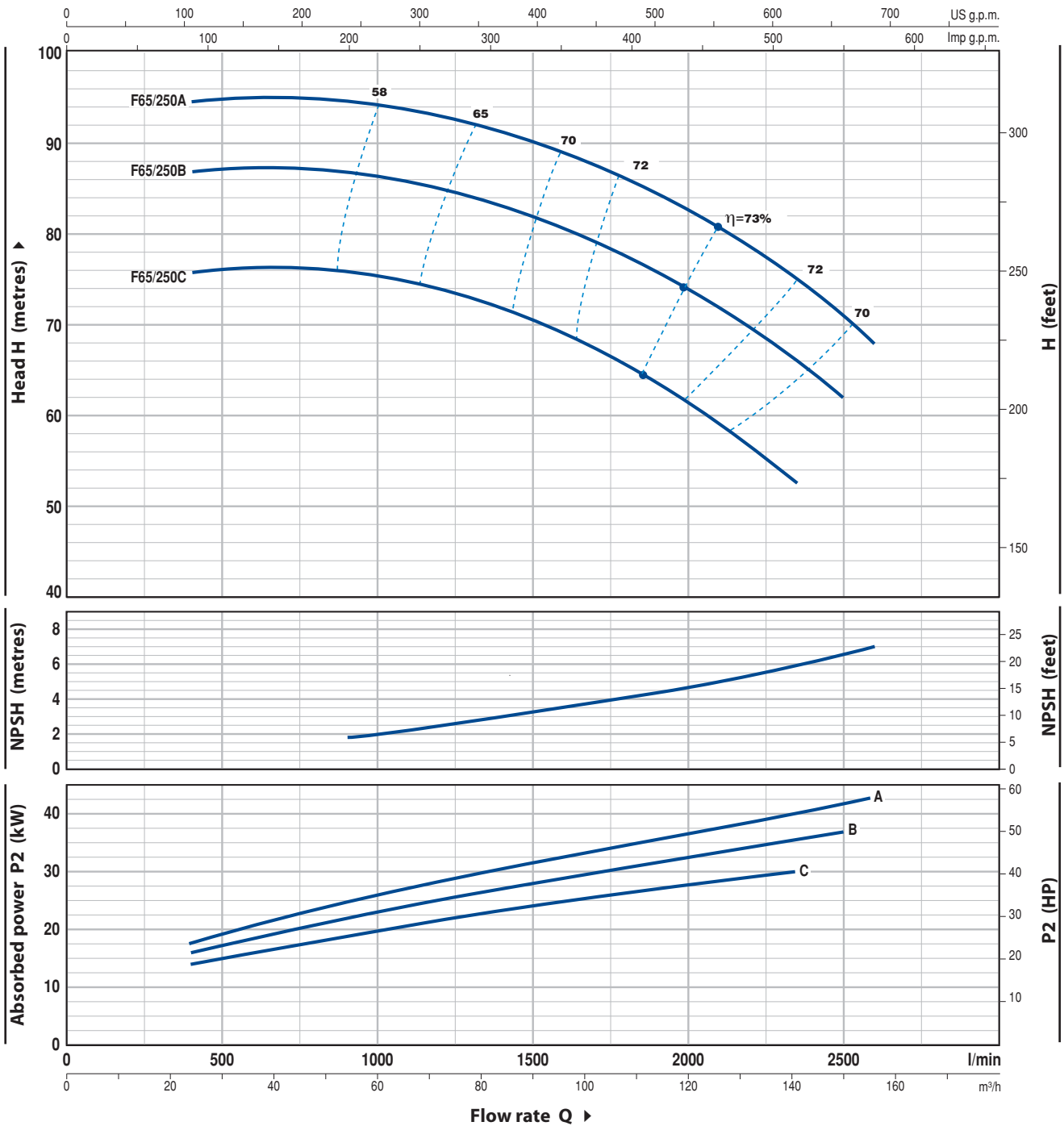

MODEL	POWER		Q	24	40	60	80	100	120	141	150	156
	kW	HP		m ³ /h	400	667	1000	1333	1667	2000	2350	2500
Three-phase			l/min									
F 65/250C	30	40	H metres	76	76	75.5	72.5	68	61.5	53		
F 65/250B	37	50		87	87	86	84	80	74	66.5	62	
F 65/250A	45	60		94.5	95	94	92	88	82.5	75	71	68

Q = Flow rate H = Total manometric head HS = Suction height

Tolerance of characteristic curves in compliance with EN ISO 9906 App. A.

F80/160

CHARACTERISTIC CURVES AND PERFORMANCE DATA

50 Hz n= 2900 1/min HS= 0 m

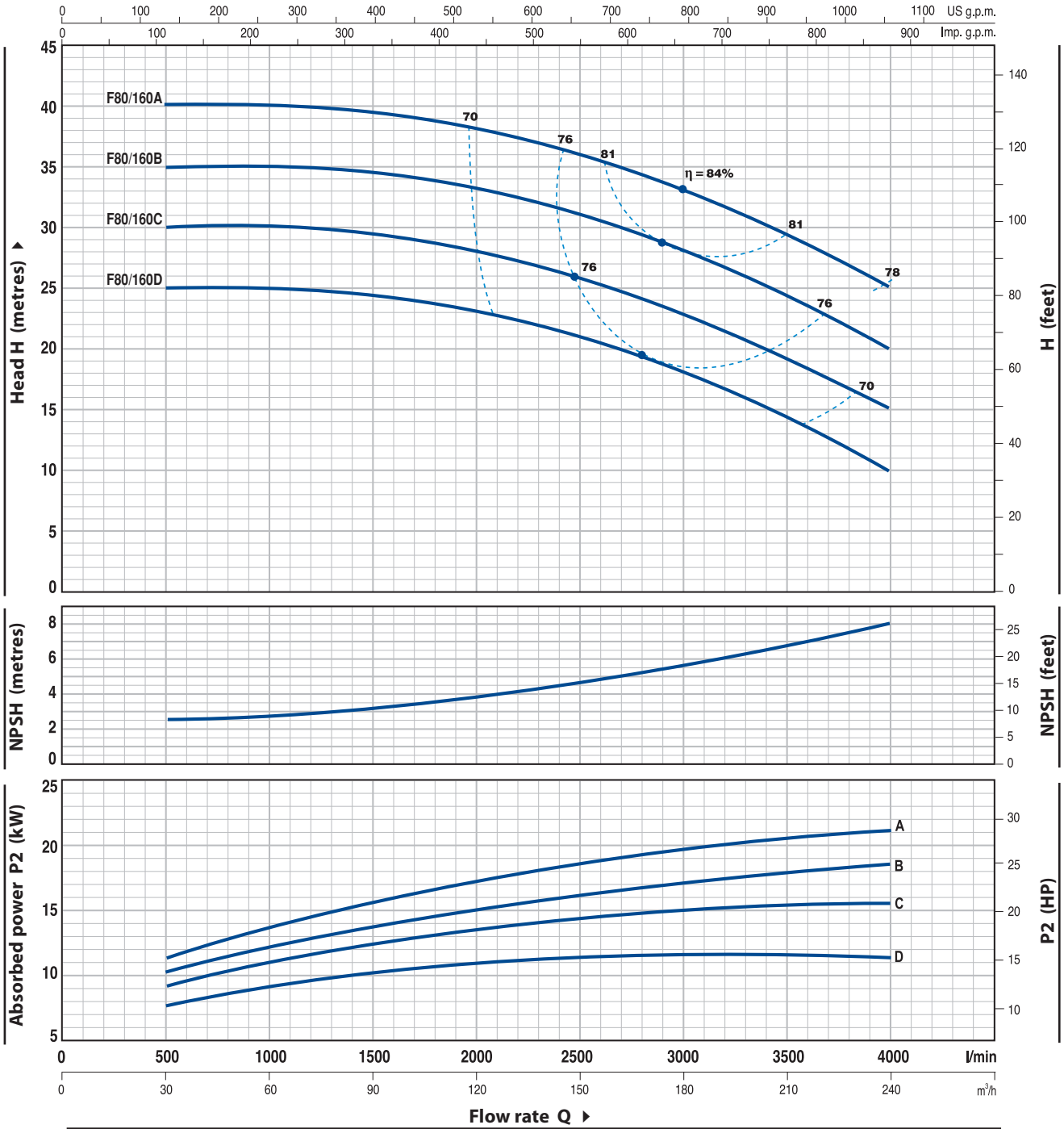

MODEL	POWER		Q	H metres											
	kW	HP		0	30	60	90	120	150	180	210	240			
Three-phase			Q	0	500	1000	1500	2000	2500	3000	3500	4000			
F 80/160D	11	15	H metres	25	25	25	24.5	23.5	21	18	14.5	10			
F 80/160C	15	20		30	30	30	29.5	28.5	26	23	19.5	15			
F 80/160B	18.5	25		35	35	35	34.5	33.5	31	28.5	24.5	20			
F 80/160A	22	30		40	40	40	39.5	38.5	36	33	29.5	25			

Q = Flow rate H = Total manometric head HS = Suction height

Tolerance of characteristic curves in compliance with EN ISO 9906 App. A.

CHARACTERISTIC CURVES AND PERFORMANCE DATA

50 Hz n= 2900 1/min HS= 0 m

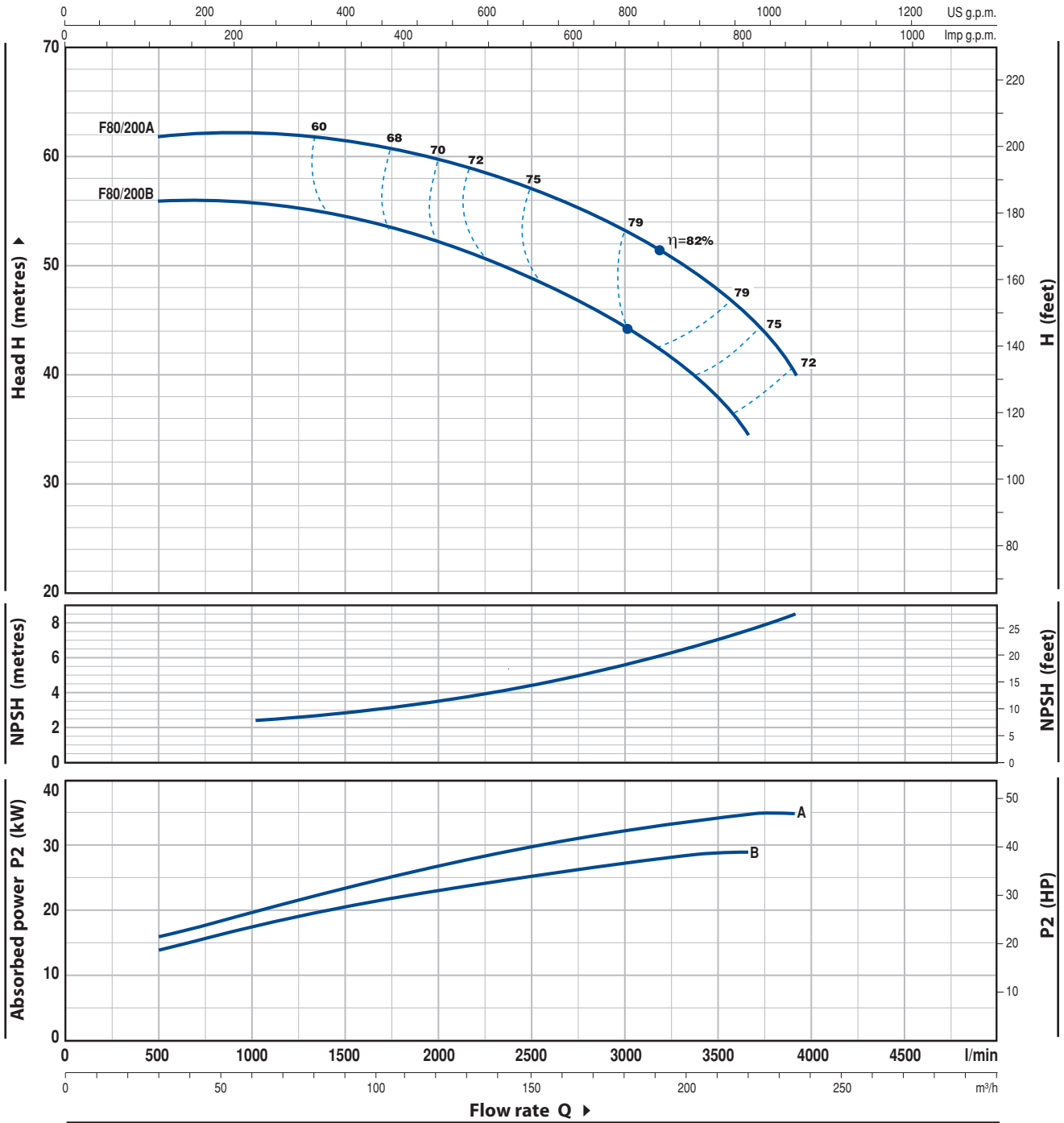

MODEL	POWER		Q	Flow rate						
	kW	HP		m ³ /h	l/min	l/min	l/min	l/min	l/min	l/min
Three-phase				30	50	100	150	200	219	234
F 80/200B	30	40	H metres	56	56	54	49	41	34.5	
F 80/200A	37	50	H metres	62	62	61	57	50	45.5	40

Q = Flow rate H = Total manometric head HS = Suction height

Tolerance of characteristic curves in compliance with EN ISO 9906 App. A.

F80/250

CHARACTERISTIC CURVES AND PERFORMANCE DATA

50 Hz n= 2900 1/min HS= 0 m

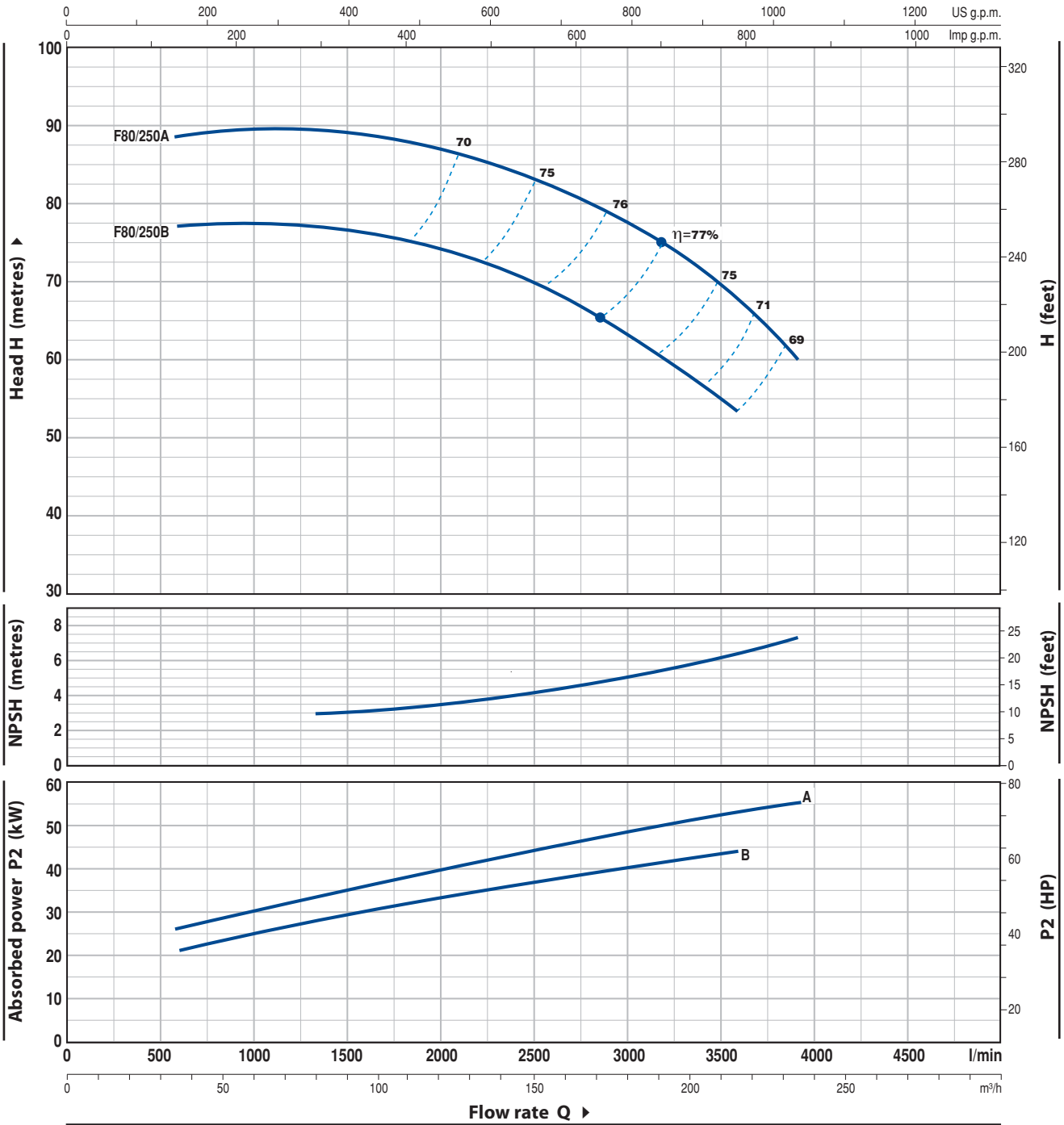

MODEL	POWER		Q	36	50	100	150	200	216	234
	kW	HP		m^3/h	50	100	150	200	216	234
Three-phase			l/min	600	833	1667	2500	3333	3600	3900
F 80/250B	45	60	H metres	77	77.5	76	70.5	58.5	54	
F 80/250A	55	75		88.5	89.5	89	83	72	68	60

Q = Flow rate H = Total manometric head HS = Suction height

Tolerance of characteristic curves in compliance with EN ISO 9906 App. A.

CHARACTERISTIC CURVES AND PERFORMANCE DATA

50 Hz n= 2900 1/min HS= 0 m

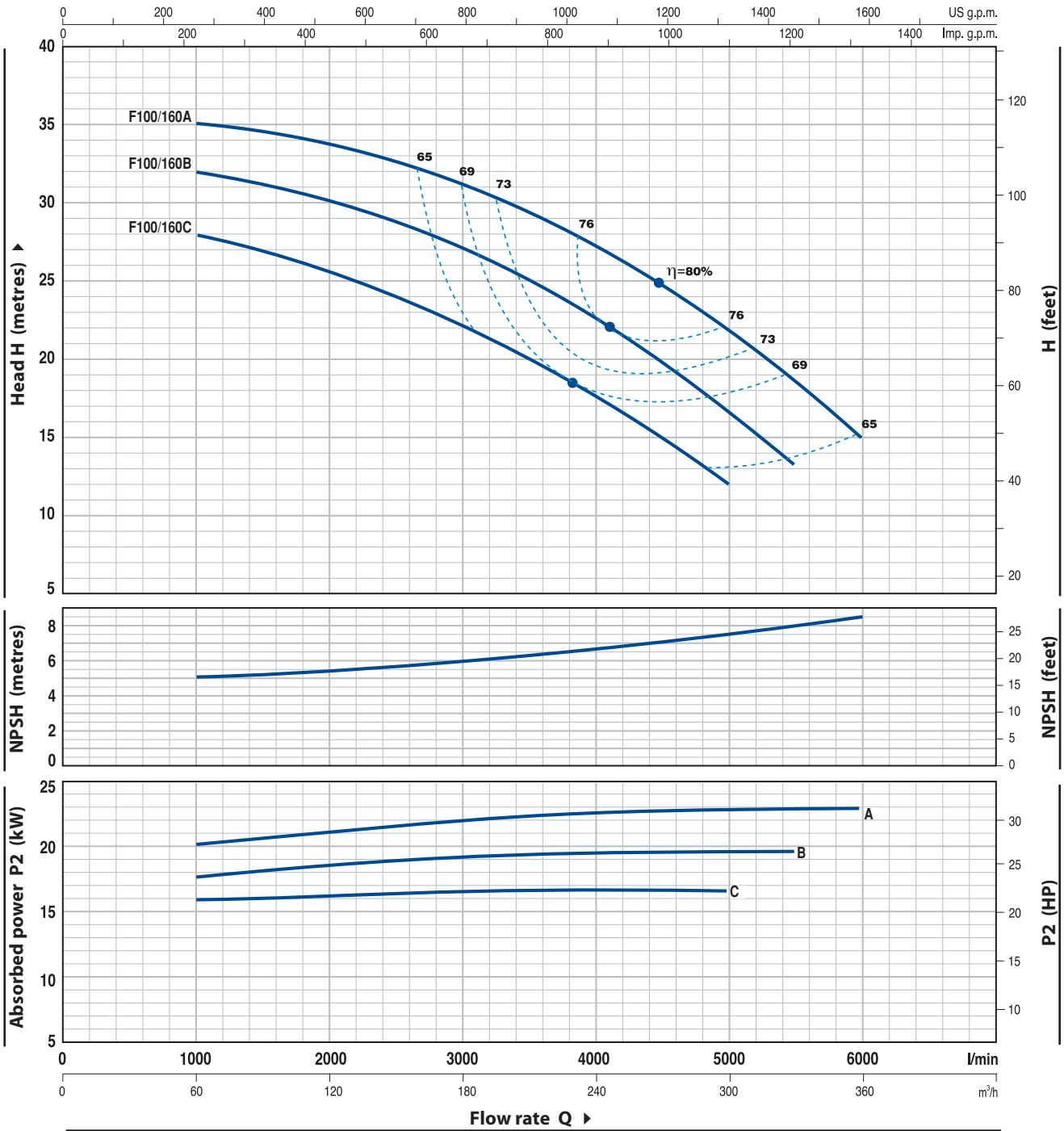

MODEL	POWER		Q	0	60	120	180	240	270	300	330	360
	kW	HP		0	1000	2000	3000	4000	4500	5000	5500	6000
Three-phase			l/min									
F 100/160C	15	20	H metres	28	28	25.5	22	17.5	15	12		
F 100/160B	18.5	25		32	32	30	27	22.5	19.5	17	13	
F 100/160A	22	30		35	35	34	31	27	24.5	22	18	15

Q = Flow rate H = Total manometric head HS = Suction height

Tolerance of characteristic curves in compliance with EN ISO 9906 App. A.

F100/200

CHARACTERISTIC CURVES AND PERFORMANCE DATA

50 Hz n= 2900 1/min HS= 0 m

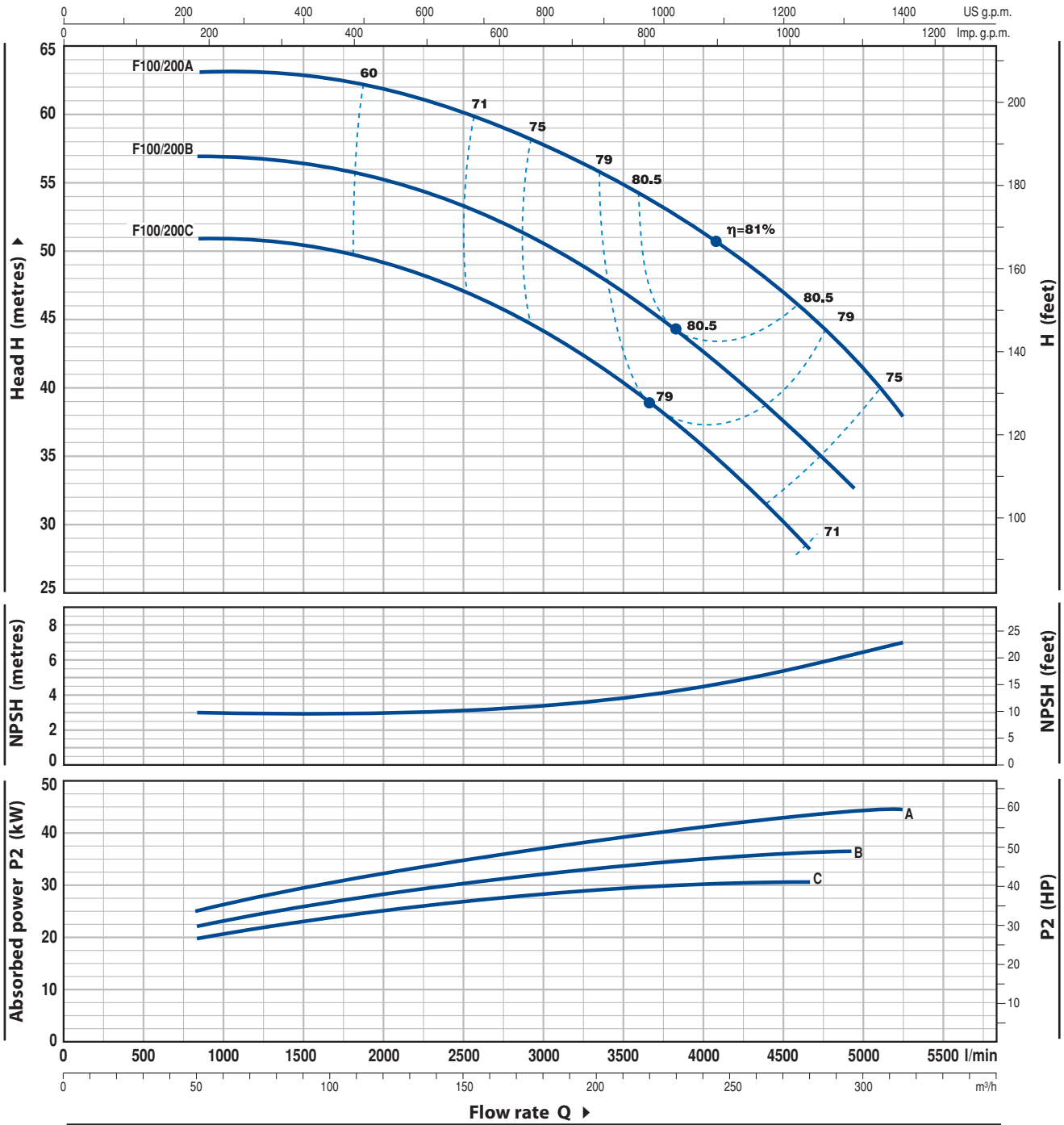

MODEL	POWER		Q	Flow rate											
	kW	HP		0	50	100	150	200	250	279	294	300	315		
Three-phase			l/min	0	833	1667	2500	3333	4167	4650	4900	5000	5250		
F 100/200C	30	40	H metres	51	51	50	47	41.5	34	28					
F 100/200B	37	50		57	57	56	53	48	41	36	33				
F 100/200A	45	60		63	63	62.5	60	56	50	45	42.5	41.5	38		

Q = Flow rate H = Total manometric head HS = Suction height

Tolerance of characteristic curves in compliance with EN ISO 9906 App. A.

CHARACTERISTIC CURVES AND PERFORMANCE DATA

50 Hz n= 2900 1/min HS= 0 m

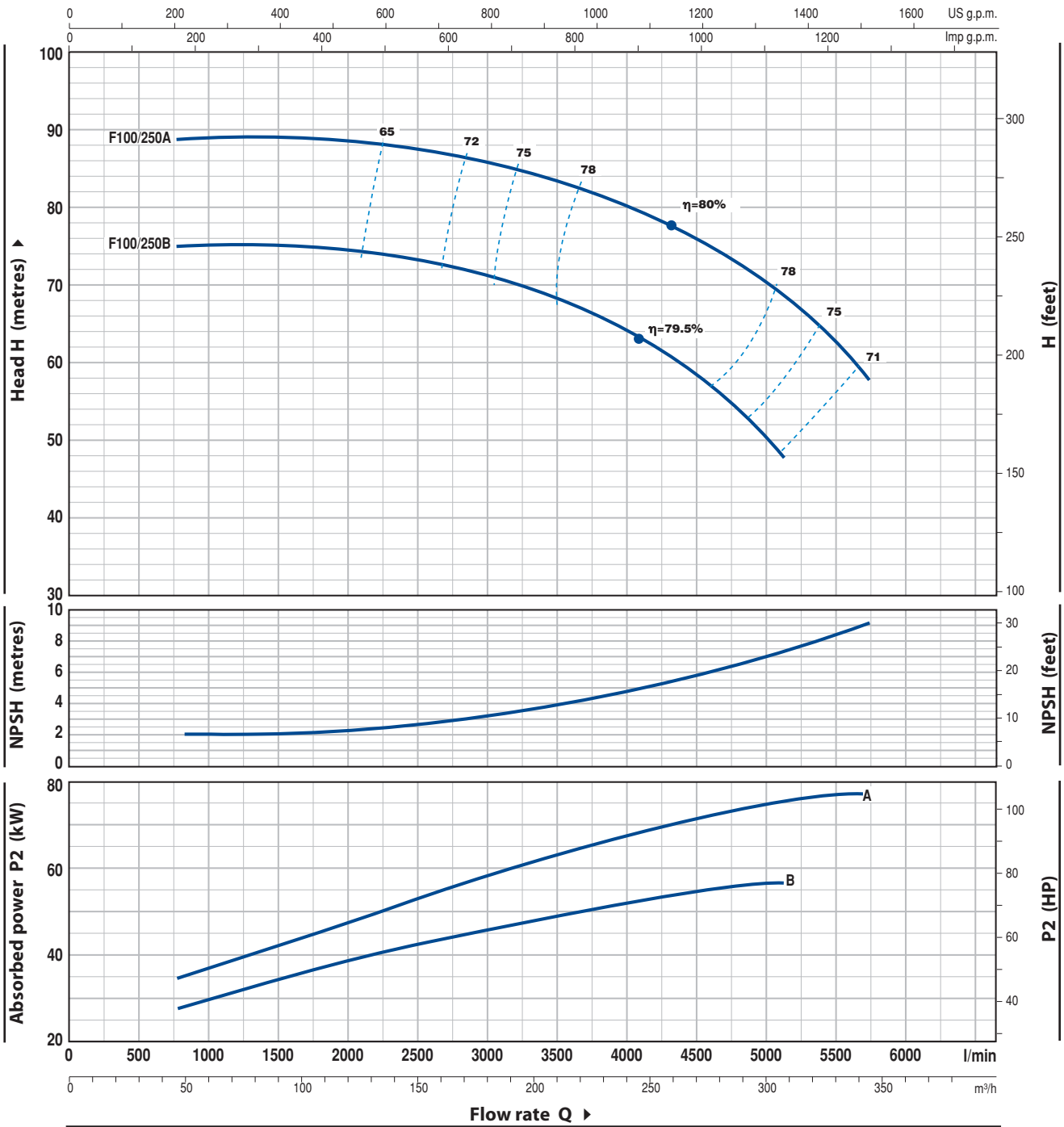

MODEL	POWER		Q	Flow rate										
	kW	HP		m ³ /h	48	96	150	180	210	240	300	309	345	
Three-phase			l/min	800	1600	2500	3000	3500	4000	5000	5150	5750		
F 100/250B	55	75	H metres	75	75	74	71.5	69	64.5	51	48			
F 100/250A	75	100		89	89	88.5	87	84	80.5	70.5	69	58		

Q = Flow rate H = Total manometric head HS = Suction height

Tolerance of characteristic curves in compliance with EN ISO 9906 App. A.

POS.	COMPONENT	CONSTRUCTION CHARACTERISTICS					
1	PUMP BODY	Cast iron, complete with flanged suction and delivery ports					
2	COUNTERFLANGES	Steel, complete with ISO 228/1 thread					
3a	BODY BACKPLATE	Cast iron					
3b	MOTOR BRACKET	Cast iron					
4	IMPELLER	Brass for F32/160, F32/200, F40/160, F40/200, F50/125, F50/160 Cast iron for F40/250, F50/200, F50/250, F65/125, F65/160, F65/200, F65/250, F80/160, F80/200, F80/250, F100/160, F100/200, F100/250					
5	MOTOR SHAFT	Stainless steel EN 10088-3 - 1.4104					
6	MECHANICAL SEAL	Pump Model		Seal Model	Shaft Diameter	Materials Stationary ring Rotational ring Elastomer	
		F32/160 F50/125	F40/160	FN-20	Ø 20 mm	Graphite	Ceramic NBR
		F32/200 F50/160	F40/200 F65/125	FN-24	Ø 24 mm	Graphite	Ceramic NBR
		F50/200 F65/200 F100/160	F65/160 F80/160	FN-32 NU	Ø 32 mm	Graphite	Ceramic NBR
		F40/250 F65/250	F50/250 F80/200	FN-38	Ø 38 mm	Graphite	Ceramic NBR
		F80/250B F80/250A	F100/200 F100/250	FN-40 FH-45 NU	Ø 40 mm Ø 45 mm	Graphite	Ceramic NBR
						Graphite	Ceramic NBR
7	BEARINGS	Pump Model		Pump Model			
		Fm32/160C F32/160C F32/160B F40/160C F50/125C	6206 ZZ - C3 / 6204 ZZ	F32/200 F40/200 F50/160 F65/125	6307 ZZ - C3 / 6206 ZZ - C3		
		Fm32/160B F32/160A Fm40/160C F40/160B Fm50/125C F50/125B	6206 ZZ - C3 / 6205 ZZ	F40/250 F50/200 F50/250 F65/160 F65/200 F80/160 F100/160	6310 ZZ - C3 / 6308 ZZ - C3		
		F40/160A F50/125A	6306 ZZ - C3 / 6206 ZZ - C3	F65/250 F80/200 F80/250B F100/200 F80/250A F100/250	6312 ZZ - C3 / 6212 ZZ - C3 6314 ZZ - C3 / 6314 ZZ - C3		
8	CAPACITOR	Pump Single-phase		Capacitance (230 V or 240 V)			
		Fm32/160C		45 µF 450 VL			
		Fm32/160B		70 µF 450 VL			
		Fm40/160C		70 µF 450 VL			
		Fm50/125C		70 µF 450 VL			
9	ELECTRIC MOTOR	Fm: single-phase 230 V - 50 Hz with thermal overload protector built-in to the winding (up to 1.5 kW) F: three-phase 230/400 V - 50 Hz up to 4 kW 400/690 V - 50 Hz from 5.5 to 75 kW ⇒ Pumps fitted with the three-phase motor option offer IE2 (IEC 60034-30) class high performance – Insulation: F class – Protection: IP 55					

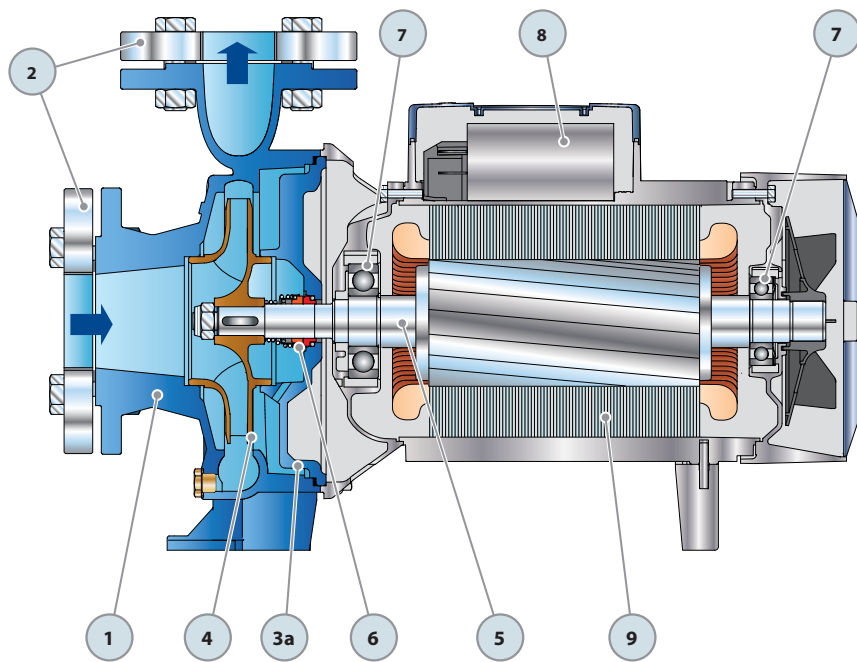

Single-phase version

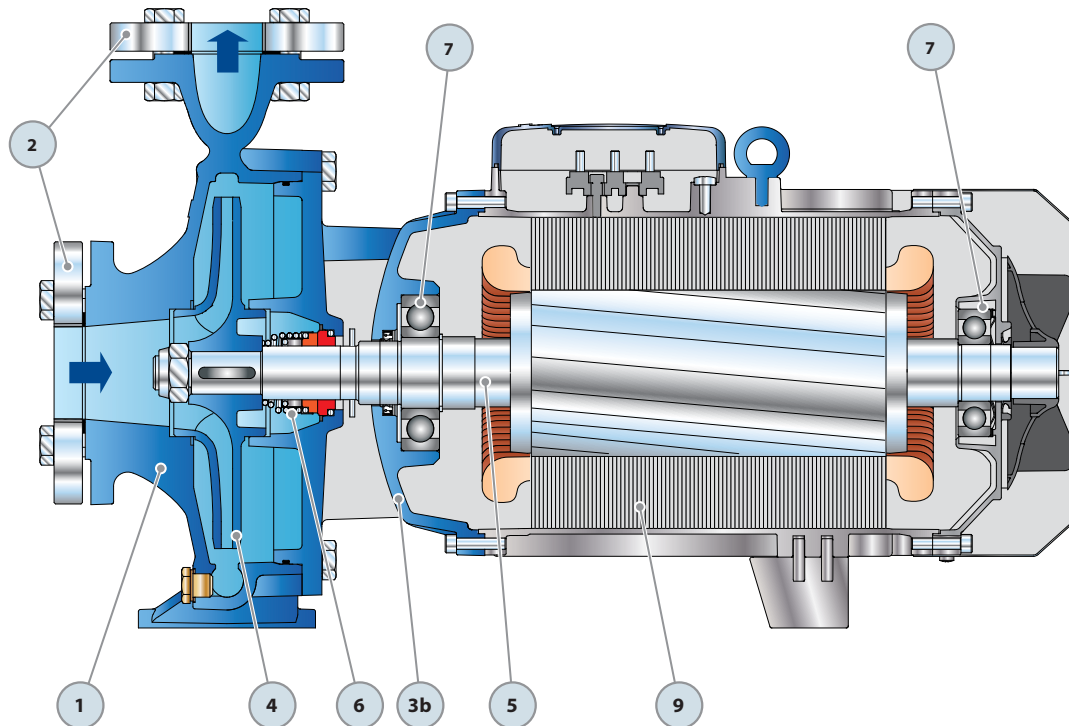

Three-phase version

DIMENSIONS AND WEIGHT

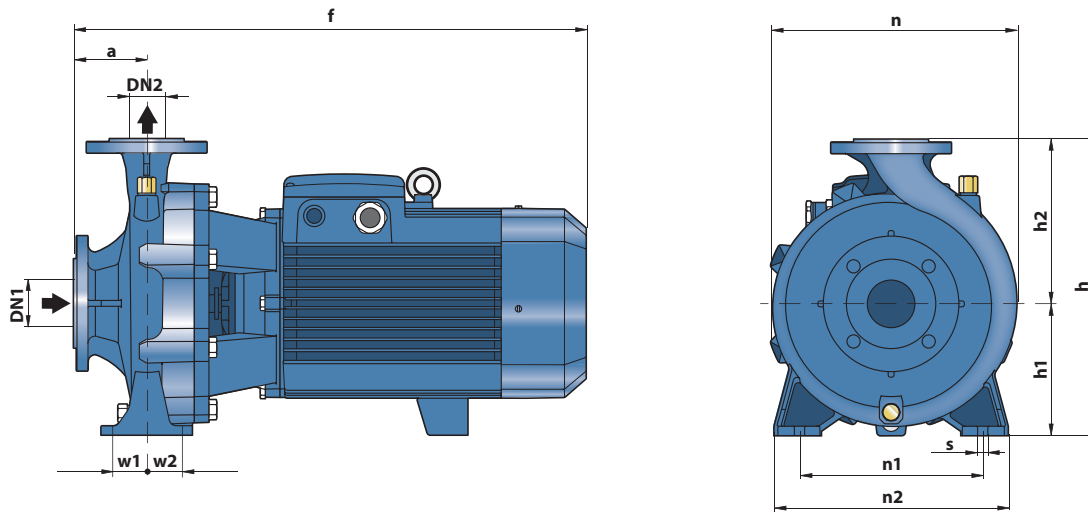

MODEL		PORTS		DIMENSIONS mm											kg *									
Single-phase	Three-phase	DN1	DN2	a	f	h	h1	h2	n	n1	n2	w1	w2	s	1~	3~								
Fm 32/160C	F 32/160C	50	32	80	412	292	132	160	242	190	240	35	35	14	39.2	37.0								
Fm 32/160B	F 32/160B				42.6										38.5									
-	F 32/160A				-	42.6																		
-	F 32/200C				-	52.0																		
-	F 32/200B				-	57.0																		
-	F 32/200A				-	61.0																		
-	F 32/200BH				-	47.9																		
-	F 32/200AH				-	51.1																		
Fm 40/160C	F 40/160C				65	40	80	412	292						132	160	240	212	265	47.5	47.5	14	43.9	40.0
-	F 40/160B							43.1															44.0	
-	F 40/160A	46.5	50.1																					
-	F 40/200B	-	61.0																					
-	F 40/200A	-	67.0																					
-	F 40/250C	-	103.0																					
-	F 40/250B	-	109.0																					
-	F 40/250A	-	125.0																					
Fm 50/125C	F 50/125C	65	50	100				431	292	132	160	242	190	240	35	35	14						44.2	40.1
-	F 50/125B							450															44.1	
-	F 50/125A				484	50.7																		
-	F 50/160C				489	340	180	269	212	265	35	35						14	-	55.0				
-	F 50/160B				535														60.6					
-	F 50/160A				616	360	160	200	316	212	265	47.5						47.5	14	-	64.7			
-	F 50/200C				711															106.0				
-	F 50/200B				717															128.0				
-	F 50/200A				743	405	180	225	337	250	320	250						320	60	60	18	-	135.0	
-	F 50/250D				606																	106.0		
-	F 50/250C	606	113.4																					
-	F 50/250B	701	129.6																					
-	F 50/250A	701	146.0																					
-	F 50/250AR	733	155.0																					
-	F 65/125C	511	340	180	291								212	280	47.5	47.5	14					-	62.7	
-	F 65/125B	557																				66.8		
-	F 65/125A	621																				74.0		
-	F 65/160C	621	360	200	300								212	280	47.5	47.5	14					-	100.0	
-	F 65/160B	716				106.5																		
-	F 65/160A	719				123.0																		
-	F 65/200B	719	405	180	225	340	250	320	250	320	60	60	18	-	128.0									
-	F 65/200A	751												125.0										
-	F 65/200AR	751												153.1										
-	F 80/160D	652	480	200	280	330	280	360	280	360	60	60	18	-	111.5									
-	F 80/160C	747												126.0										
-	F 80/160B	747												143.5										
-	F 80/160A	779	480	200	280	362	280	360	280	360	60	60	18	-	153.0									
-	F 100/160C	758												139.0										
-	F 100/160B	758												153.7										
-	F 100/160A	790	165.0																					

(*weight includes counterflanges)

DIMENSIONS AND WEIGHT

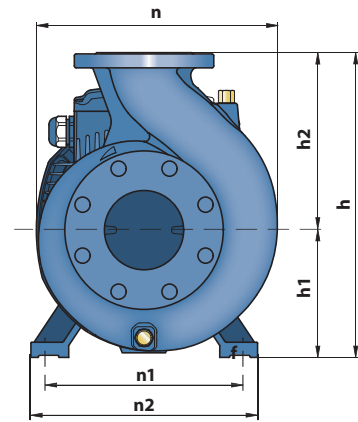
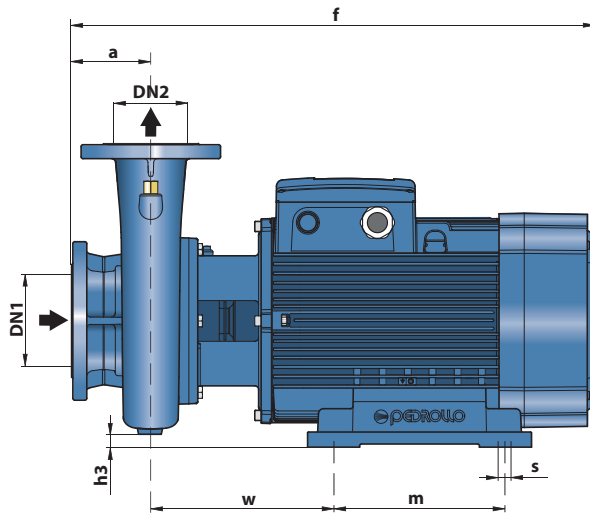

DN FLANGES	D mm	K mm	HOLES	
			N°	Ø (mm)
32	140	100	4	18
40	150	110		
50	165	125		
65	185	145		
80	200	160	8	18
100	220	180		
125	250	210		

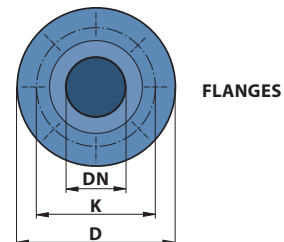

MODEL	PORTS		DIMENSIONS mm											kg *	
	DN1	DN2	a	f	h	h1	h2	h3	n	n1	n2	w	m		s
Three-phase															3~
F 65/250C	80	65	100	796	450	200	250	15	369	318	360	269.5	305	18.5	210.0
F 65/250B				847											230.0
F 65/250A				847											230.0
F 80/200B	100	80	125	824	430	280	25	360	400	490	294	350	24	212.0	
F 80/200A				875										222.5	
F 80/250B				872										245.0	
F 80/250A	125	100	140	1015	620	250	280	55	490	400	490	300	350	24	497.0
F 100/200C				824											208.5
F 100/200B				875											239.0
F 100/200A	125	100	140	875	480	200	280	0	391	318	360	269.5	305	18.5	240.0
F 100/250B				875											498.5
F 100/250A				875											498.5

(*weight includes counterflanges)

COUNTERFLANGES

DN FLANGES	F COUNTERFLANGES	D mm	K mm	HOLES	
				N°	Ø (mm)
32	1¼"	140	100	4	18
40	1½"	150	110		
50	2"	165	125		
65	2½"	185	145		
80	3"	200	160	8	18
100	4"	220	180		
125	5"	250	210		

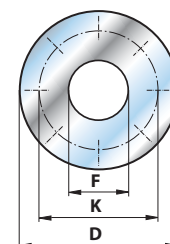

ABSORPTION

MODEL	VOLTAGE (single-phase)	
	230 V	240 V
Single-phase	230 V	240 V
Fm 32/160C	11.0 A	10.0 A
Fm 32/160B	15.0 A	13.8 A
Fm 40/160C	15.0 A	13.8 A
Fm 50/125C	15.0 A	13.8 A

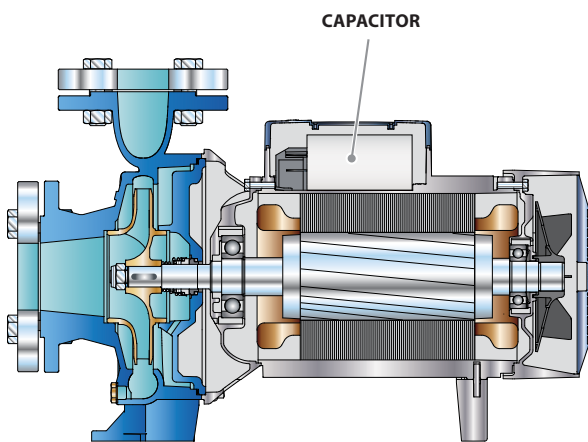

Single-phase version

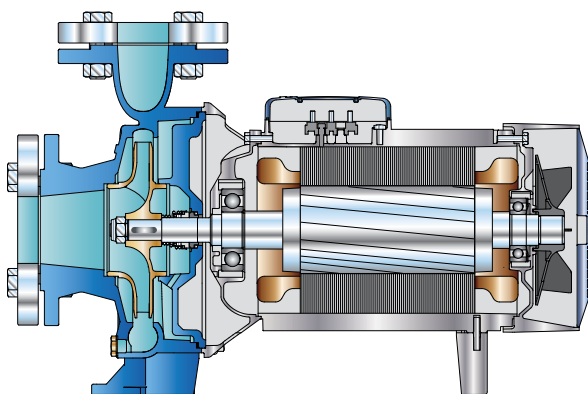

Three-phase version

MODEL	VOLTAGE (three-phase)		
	230÷240 V	400÷415 V	690÷720 V
Three-phase	230÷240 V	400÷415 V	690÷720 V
F 32/160C	7.5 A	4.3 A	2.5 A
F 32/160B	10.0 A	5.8 A	3.4 A
F 32/160A	12.0 A	7.3 A	4.2 A
F 32/200C	17.9 A	10.3 A	5.9 A
F 32/200B	–	11.7 A	6.7 A
F 32/200A	–	14.9 A	8.6 A
F 32/200BH	12.6 A	7.3 A	4.2 A
F 32/200AH	15.4 A	8.9 A	5.1 A
F 40/160C	9.9 A	5.7 A	3.3 A
F 40/160B	12.0 A	6.9 A	4.0 A
F 40/160A	17.2 A	9.9 A	5.7 A
F 40/200B	–	12.6 A	7.3 A
F 40/200A	–	15.6 A	9.0 A
F 40/250C	–	21.0 A	12.1 A
F 40/250B	–	23.5 A	13.6 A
F 40/250A	–	30.5 A	17.6 A
F 50/125C	9.4 A	5.4 A	3.1 A
F 50/125B	12.0 A	6.9 A	4.0 A
F 50/125A	16.3 A	9.4 A	5.4 A
F 50/160C	15.8 A	9.1 A	5.3 A
F 50/160B	–	12.3 A	7.1 A
F 50/160A	–	15.5 A	8.9 A
F 50/200C	–	23 A	13.3 A
F 50/200B	–	29.5 A	17 A
F 50/200A	–	34.5 A	20 A
F 50/200AR	–	41.5 A	24 A
F 50/250D	–	17.2 A	9.9 A
F 50/250C	–	21.0 A	12.0 A
F 50/250B	–	27.0 A	15.6 A
F 50/250A	–	34.0 A	19.6 A
F 50/250AR	–	41.0 A	24.0 A
F 65/125C	17.5 A	10.0 A	5.8 A
F 65/125B	–	12.0 A	7.0 A
F 65/125A	–	16.5 A	9.5 A
F 65/160C	–	19.0 A	11.0 A
F 65/160B	–	23.0 A	13.5 A
F 65/160A	–	27.5 A	16.0 A
F 65/200B	–	30.0 A	17.3 A
F 65/200A	–	35.0 A	20.2 A
F 65/200AR	–	41.0 A	24.0 A
F 65/250C	–	53.0 A	31.0 A
F 65/250B	–	65.0 A	38.0 A
F 65/250A	–	79.0 A	46.0 A
F 80/160D	–	22.0 A	13.0 A
F 80/160C	–	29.0 A	17.0 A
F 80/160B	–	34.5 A	20.0 A
F 80/160A	–	39.0 A	22.5 A
F 80/200B	–	53.0 A	31.0 A
F 80/200A	–	65.0 A	38.0 A
F 80/250B	–	79.0 A	46.0 A
F 80/250A	–	98.0 A	57.0 A
F 100/160C	–	31.0 A	18.0 A
F 100/160B	–	36.0 A	21.0 A
F 100/160A	–	42.0 A	24.0 A
F 100/200C	–	53.0 A	31.0 A
F 100/200B	–	65.0 A	38.0 A
F 100/200A	–	79.0 A	46.0 A
F 100/250B	–	98.0 A	57.0 A
F 100/250A	–	126.0A	73.0 A

PALLETIZATION

MODEL		GROUPAGE				CONTAINER			
Single-phase	Three-phase	n° pumps	H (mm)	kg		n° pumps	H (mm)	kg	
				1~	3~			1~	3~
Fm 32/160C	F 32/160C	18	1430	730	683	24	1860	967	905
Fm 32/160B	F 32/160B	18	1430	781	707	24	1860	1036	936
-	F 32/160A	18	1430	-	784	24	1860	-	1040
-	F 32/200C	12	1535	-	641	16	2000	-	849
-	F 32/200B	12	1535	-	701	16	2000	-	929
-	F 32/200A	12	1535	-	749	16	2000	-	993
-	F 32/200BH	12	1535	-	591	16	2000	-	783
-	F 32/200AH	12	1535	-	629	16	2000	-	833
Fm 40/160C	-	12	1400	509	-	16	1820	673	-
-	F 40/160C	18	1430	-	735	24	1860	-	975
-	F 40/160B	18	1430	-	809	24	1860	-	1073
-	F 40/160A	12	1400	-	617	16	1820	-	817
-	F 40/200B	12	1535	-	749	16	2000	-	993
-	F 40/200A	12	1535	-	821	16	2000	-	1089
-	F 40/250C	6	1200	-	635	9	1730	-	944
-	F 40/250B	6	1200	-	671	9	1730	-	998
-	F 40/250A	6	1200	-	767	9	1730	-	1142
Fm 50/125C	-	18	1430	820	-	24	1860	1088	-
-	F 50/125C	12	1400	-	498	16	1820	-	659
-	F 50/125B	18	1430	-	810	24	1860	-	1075
-	F 50/125A	12	1535	-	625	16	2000	-	828
-	F 50/160C	12	1535	-	677	16	2000	-	897
-	F 50/160B	12	1535	-	744	16	2000	-	987
-	F 50/160A	12	1535	-	793	16	2000	-	1052
-	F 50/200C	6	1200	-	653	9	1730	-	971
-	F 50/200B	6	1200	-	785	9	1730	-	1169
-	F 50/200A	6	1200	-	827	9	1730	-	1232
-	F 50/200AR	6	1380	-	899	9	2000	-	1340
-	F 50/250D	6	1200	-	653	9	1730	-	971
-	F 50/250C	6	1200	-	697	9	1730	-	1037
-	F 50/250B	6	1200	-	794	9	1730	-	1183
-	F 50/250A	6	1200	-	893	9	1730	-	1331
-	F 50/250AR	6	1380	-	947	9	2000	-	1412
-	F 65/125C	12	1535	-	769	16	2000	-	1020
-	F 65/125B	12	1535	-	818	16	2000	-	1085
-	F 65/125A	12	1535	-	905	16	2000	-	1201
-	F 65/160C	6	1200	-	617	9	1730	-	917
-	F 65/160B	6	1200	-	656	9	1730	-	976
-	F 65/160A	6	1200	-	755	9	1730	-	1018
-	F 65/200B	6	1200	-	785	9	1730	-	1169
-	F 65/200A	6	1200	-	767	9	1730	-	1142
-	F 65/200AR	6	1380	-	936	9	2000	-	1395
-	F 65/250C	1	450	-	227	-	-	-	-
-	F 65/250B	1	450	-	247	-	-	-	-
-	F 65/250A	1	450	-	247	-	-	-	-
-	F 80/160D	6	1200	-	686	9	1730	-	1021
-	F 80/160C	6	1380	-	773	9	2000	-	1151
-	F 80/160B	6	1380	-	878	9	2000	-	1309
-	F 80/160A	6	1380	-	935	9	2000	-	1394
-	F 80/200B	1	450	-	229	-	-	-	-
-	F 80/200A	1	450	-	240	-	-	-	-
-	F 80/250B	1	450	-	262	-	-	-	-
-	F 80/250A	1	770	-	514	-	-	-	-
-	F 100/160C	6	1380	-	851	9	2000	-	1256
-	F 100/160B	6	1380	-	939	9	2000	-	1437
-	F 100/160A	6	1380	-	1007	9	2000	-	1502
-	F 100/200C	1	450	-	226	-	-	-	-
-	F 100/200B	1	450	-	256	-	-	-	-
-	F 100/200A	1	450	-	257	-	-	-	-
-	F 100/250B	1	770	-	516	-	-	-	-
-	F 100/250A	1	770	-	516	-	-	-	-

