

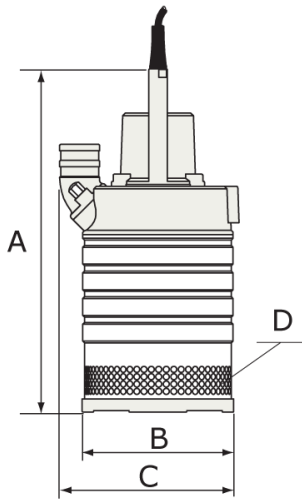

## Minette Inox

Electrical submersible pump



50 Hz	Minette Inox
Discharge connection	3"
Rated power $P_2$ [kW]	2.0
Max. power consumption $P_1$ [kW]	2.6
Shaft speed [r.p.m.]	2715
Rated current at 230V	7,7 A
Rated current at 400V	4,4 A
Rated current at 500V	3,4 A
Solids passage D	7,5 mm
Dimensions A / B / C	535 / 240 / 295 mm
Weight	44 kg

Other voltages on request

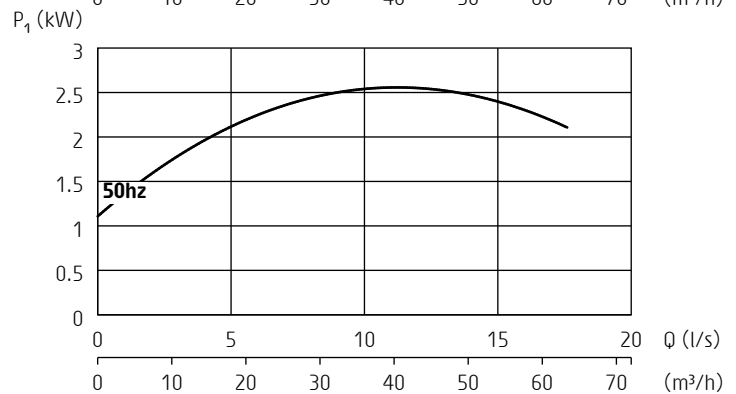
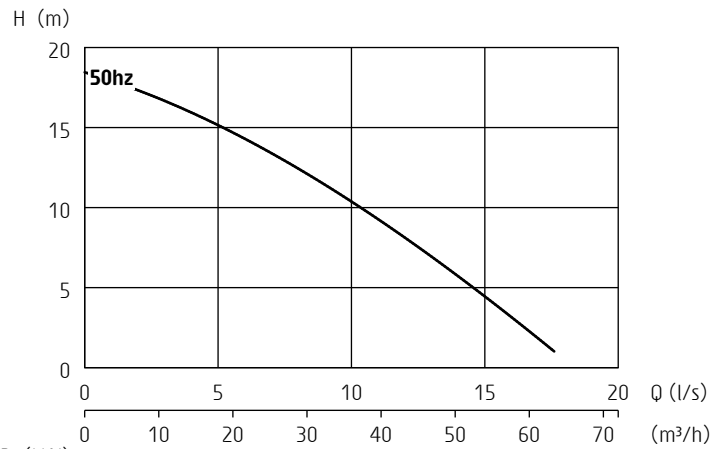

ISO 9906/A

### General description

Submersible drainage pump made of stainless steel for mines, processing industries and salt-water applications

### Classification

Electrical submersible pump  
Protection class: IP 68

### Electrical motor

Squirrel cage induction motor  
Insulation class: F (IEC 85)

### Motor protection

Phase sequence control, phase failure guard, temperature guard with thermal contacts in the stator (= SMART system). Air valve

### Cable - SubCab 20 m (66 ft)

50 Hz 230 - 500V: 4G2.5mm<sup>2</sup>  
60 Hz 230 - 575V: AWG12/4

### Limitations

Max. submersion depth: 20 m (66 ft)  
Max. liquid temperature: 40 °C (104 °F)  
Allowed pH range: 2 - 10  
Maximum liquid density: 1100 kg/m<sup>3</sup> (68 lbs/ft<sup>3</sup>)

### Shaft seals

Double mechanical shaft seals running in an oil compartment  
Material lower seal: *silicon carbide - silicon carbide*  
Material upper seal: *carbon - silicon carbide*

### Bearings

Ball bearings with C3 clearance

### Discharge connection

3" hose, Iso-G BSP or NPT

### Materials

Casted parts: *Stainless steel (EN 10283-1.4412-ASTM CF-8M)*  
Outer casing: *Stainless steel (EN 10088-3-1.4436-AISI 316L)*  
Motor shaft: *Stainless steel (EN 10088-3-1.4460-AISI 329)*  
Impeller: *Stainless steel (EN 10283-1.4412-ASTM CF-8M)*  
Diffusers: *Nitrile rubber*  
Screws and nuts: *Stainless steel (A4)*  
O-rings: *Viton rubber*

### Accessories

Zinc anodes



Hoogeindsestraat 5  
NL - 5447 PD Rijkevoort  
Nederland  
T : +31 (0) 485 - 371318  
F : +31 (0) 485 - 371918  
info@pompentechniek.nl  
www.pompentechniek.nl