



Hoogeindsestraat 5
NL - 5447 PD Rijkevoort
Nederland
T : +31 (0) 485 - 371318
F : +31 (0) 485 - 371918
info@pompentechniek.nl
www.pompentechniek.nl

Catalogue 2012

50Hz



• DH





Pompe da drenaggio con girante aperta per il pompaggio di liquidi con corpi in sospensione. Caratterizzate da alta prevalenza in rapporto al tipo e alla grandezza della macchina.

Drainage pump with open impeller for pumping liquids with suspended solids. Characterised by head in ratio to the type and size of the machine.

Bombas de drenaje con rodete abierto para bombear líquidos con cuerpos en suspensión. Caracterizadas por una alta prevalencia en relación con el tipo y el tamaño de la máquina.

Pompes de drainage avec turbine ouverte pour le pompage de liquides avec corps en suspension. Caractérisées par une hauteurmanométrique élevée par rapport au type et aux dimensions de la machine.

CARATTERISTICHE COSTRUTTIVE / CONSTRUCTION FEATURES
CARACTERÍSTICAS CONSTRUCTIVAS / CARACTÉRISTIQUES D'EXÉCUTION

Corpo pompa	ghisa
Pump body	cast iron
Cuerpo bomba	fundición
Corps de pompe	fonte
Camicia, coperchio motore, base appoggio	acciaio inox
Shell, motor cover, base support	stainless steel
Camisa, tapa motor, base apoyo	acero inoxidable
Chemise, couvercle moteur, support de base	acier inox
Girante	ottone
Impeller	brass
Rodete	latón
Turbine	laiton
Tenuta meccanica	doppia tenuta con barriera d'olio: carburo di silicio lato pompa, anello di tenuta lato motore
Mechanical seal	double seal with oil barrier; silicon carbide on pump side, sealing ring on motor side
Sello mecánico	doble sello con cámara interpuesta: carburo de silicio lado bomba, retén de estanqueidad lado motor
Garniture mécanique	double garniture avec film lubrifiant: carbure de silice côté pompe, joint d'étanchéité côté moteur
Albero motore	acciaio AISI 416
Motor shaft	stainless steel AISI 416
Eje motor	acero AISI 416
Arbre moteur	acier AISI 416
Passaggio corpi solidi	
Passage of solids	Ø max 10 mm
Pajo de solidos	
Passage corps solides	
Profondità di immersione	
Depth of immersion	max 5 m
Profundidad inmersión	
Profondeur immersion	
Temperatura del liquido	
Liquid temperature	0 - 40 °C
Temperatura del liquido	
Température du liquide	
Cavo	
Cable	H07 RNF, 10 m
Cable	
Câble	
G	galleggiante float switch flotador flotteur

MOTORE / MOTOR / MOTOR / MOTEUR

Motore 2 poli a induzione	3~ 230/400V-50Hz
2 pole induction motor	1~ 230V-50Hz
Motor de 2 polos a inducción	con termoprotettore with thermal protection con protección térmica
Moteur à induction à 2 pôles	avec protection thermique
Classe di isolamento	
Insulation class	F
Clase de aislamiento	
Classe d'isolation	
Grado di protezione	
Protection degree	IP68
Grado de protección	
Protection	

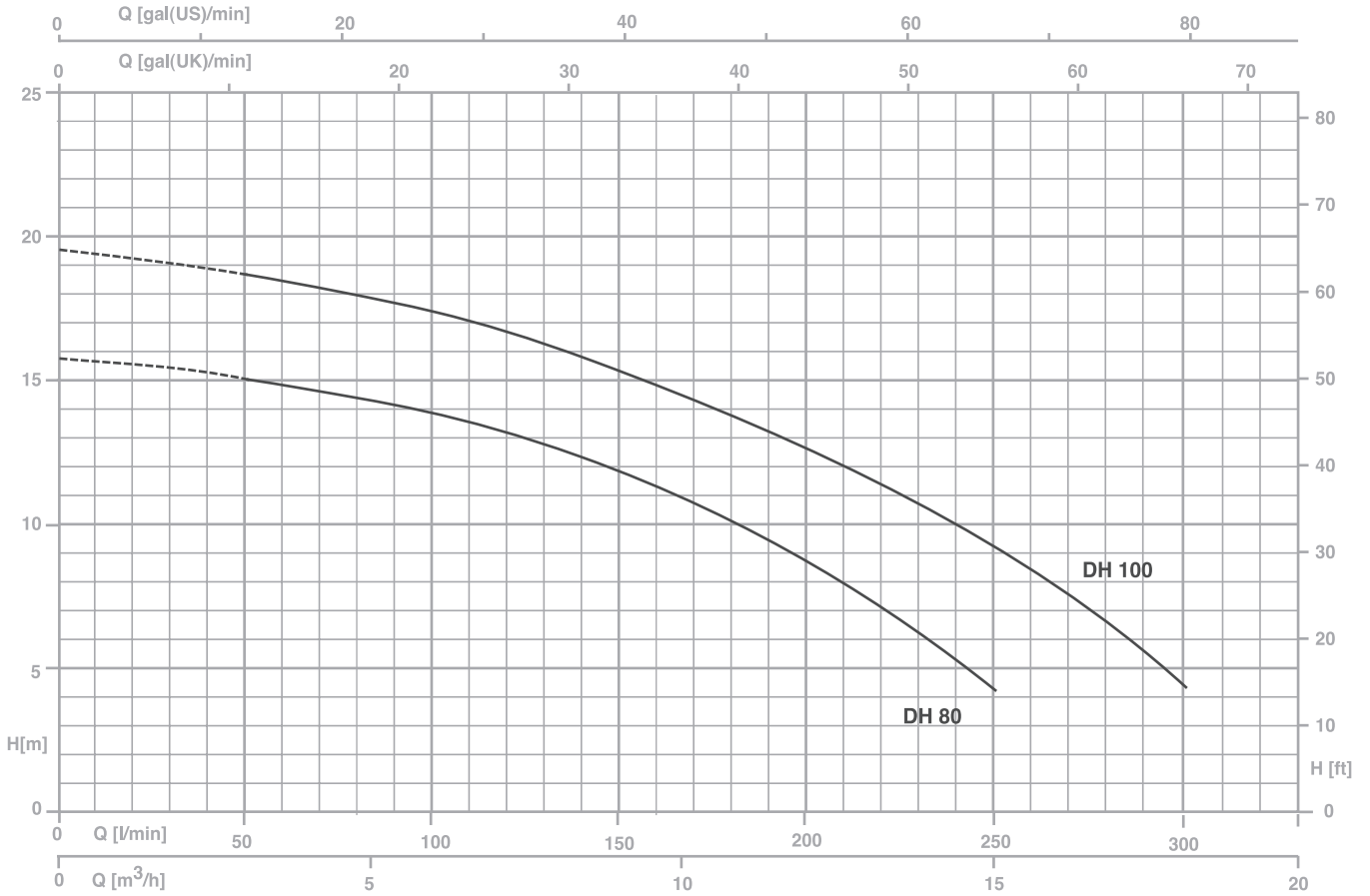

TYPE		W	AMPERE		Q (m³/h - l/min)						
1~	3~		1~	3~	0	3	6	9	12	15	18
			1x230 V 50 Hz	3x400 V 50 Hz	0	50	100	150	200	250	300
DH 80 G	-	980	4,3	2,1	15,7	14,9	13,8	11,7	8,6	4,3	-
DH 80	DHT 80	980	4,3	2,1	15,7	14,9	13,8	11,7	8,6	4,3	-
DH 100 G	-	1370	6,2	2,8	19,4	18,5	17,1	15,2	12,6	9,3	4,4
DH 100	DHT 100	1370	6,2	2,8	19,4	18,5	17,1	15,2	12,6	9,3	4,4

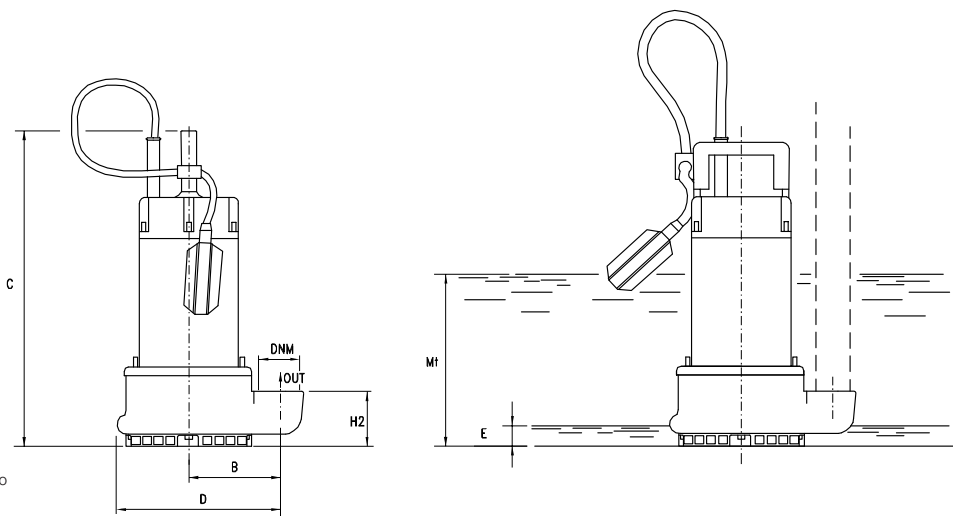

E: massimo livello di svuotamento
 E: maximum emptying level
 E: máximo nivel de vaciado
 E: niveau maximum de vidange

Mt: livello minimo di funzionamento continuo
 Mt: lowest level for continuous duty
 Mt: nivel mínimo de funcionamiento continuo
 Mt: niveau minimum de fonctionnement continuu

Dimensioni imballo
 Package dimensions
 Dimensiones embalaje
 Dimensions d'emballage

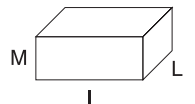

TYPE	DIMENSIONS (mm)										Kg
	B	C	D	E	H2	Mt	DNM	I	L	M	
DH 80 G	105	330	218.5	45	70	190	1" 1/2G	180	255	380	12
DH 100 G	105	330	218.5	45	70	190	1" 1/2G	180	255	380	14