

Sewage Pumps

KS - Channel Type Pumps

W, WTS - Vortex Type Pumps



Hoogeindsestraat 5
NL - 5447 PD Rijkevoort
Nederland
T : +31 (0) 485 - 371318
F : +31 (0) 485 - 371918
info@pompentechniek.nl
www.pompentechniek.nl

Design KS

Technical Data

Performance Range:

- Capacity up to 500m³/h (2200USgpm)
- Head up to 45m (150feet)
- Speed up to 1450rpm

Sizes:

- DN 65 up to DN 150 (2 1/2" up to 6") discharge

Temperature:

- max. 120°C (250°F)

Casing pressure:

- up to 10bar (145psig)

Liquids:

- Contaminated liquids with solids
- Waste water, sludge up to 8% atro
- Suspensions, effluents, etc.
- Raw, thick or thin juices

Materials:

Code	Impeller	Wear Plates	Casing, Casing Cover	Wear Rings 1)	Bearing Frame, Lantern	Shaft	Shaft Sleeve
N	Cast iron 0.6025	Cast iron 0.6025	Cast iron 0.6025	Cast iron 0.6025	Cast iron 0.6025	Stainless steel 1.4021	Stainless steel 1.4021
NL	Cast iron 0.6025		Ductile iron 0.7040				
VN	Stainless steel 1.4408		Cast iron 0.6025				
VV	Stainless steel 1.4408	Stainless steel 1.4408	Stainless steel 1.4408	Stainless steel 1.4408		Stainless steel 1.4462	

1) Casing wear ring optional

Other materials and special versions upon request

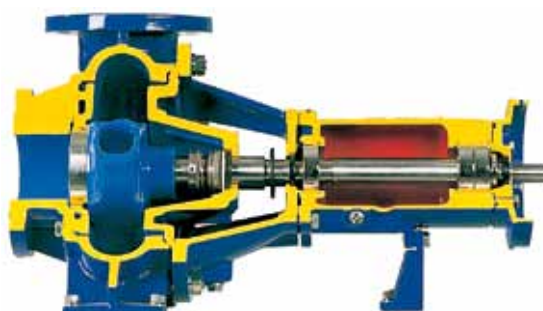
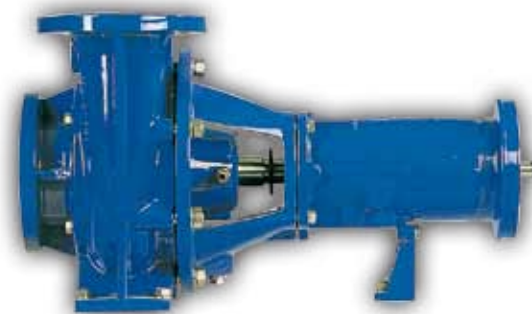

Applications:

- Industrial or public waste and sewage plants
- Chemical industry
- Mining
- smelteries
- Sugar mills
- Pulp and paper mills

Performance Range 1450rpm

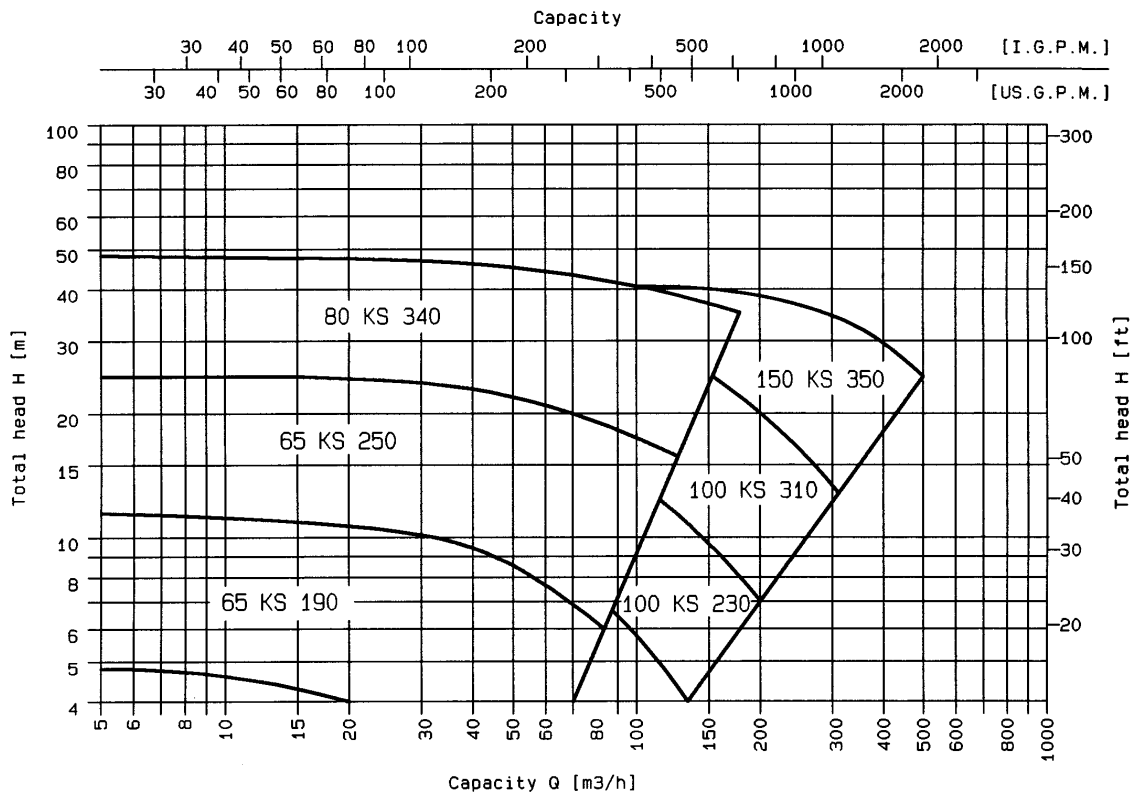

Performance Range 950rpm

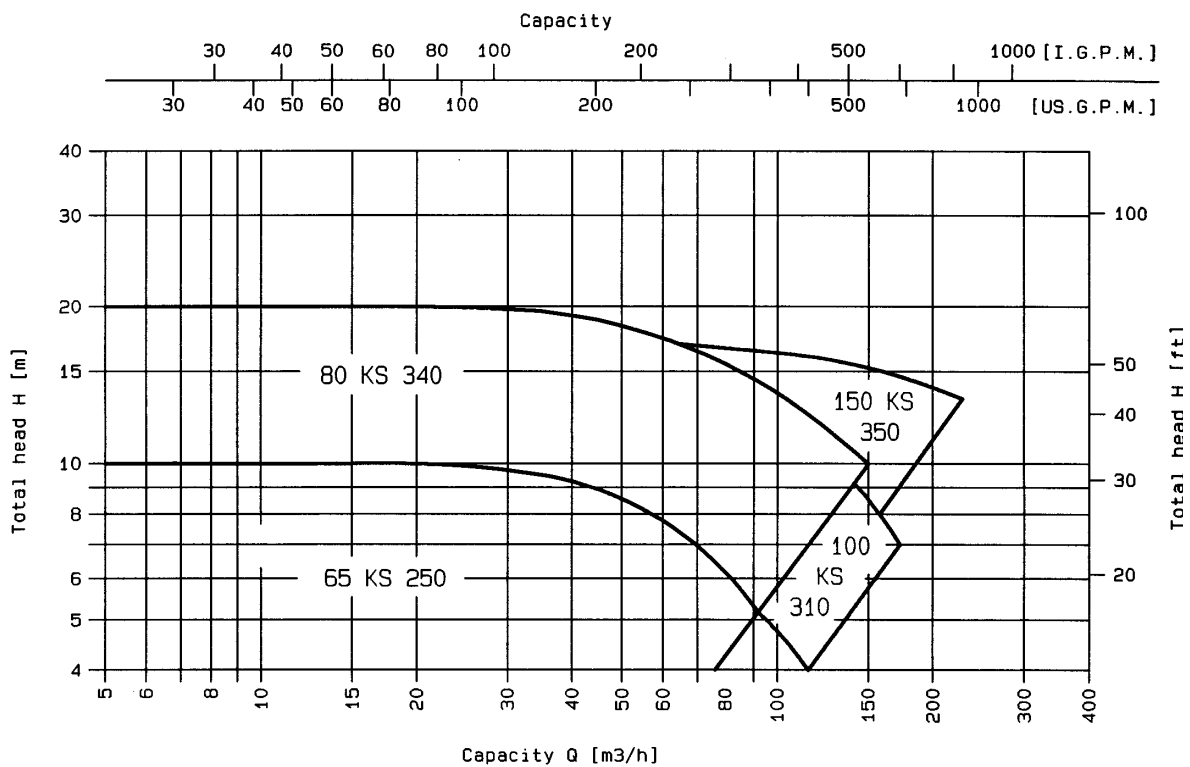

Design versions

Design KS:

Horizontal pump with closed two channel impeller with wear plate and oil lubricated bearing frame. Easy maintenance by back pull out system, disassembling of impeller and bearing frame without disturbing the suction and discharge pipes and the driving motor (spacer type coupling required). Suction branch axial, discharge branch tangential upwards.

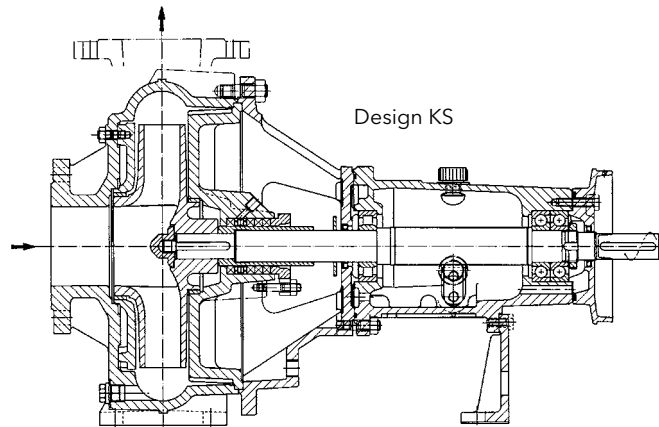

Electric drive by flexible coupling, pump and motor mounted on common base plate. Optional V-belt drive, reverse overhead mounted (huckepack design).

Design KST:

Vertical line shaft version for wet or dry installation. Drive head with motor lantern arranged above pump sump or pump floor.

Radial bearings, sleeve bearing arranged in the column pipe. Lubricated by clean water.

Installation length up to 10m.

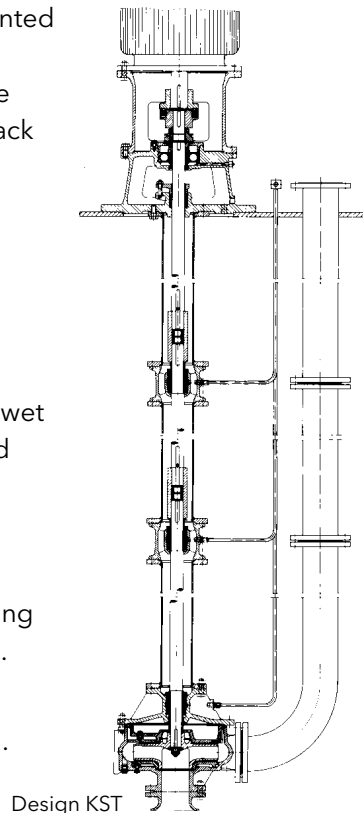

Design KSV:

Vertical short shaft version for dry pit installation. Bearing frame grease lubricated powered by vertical flanged IEC motors resting on motor lanterns either by flexible coupling or extended cardan shaft.

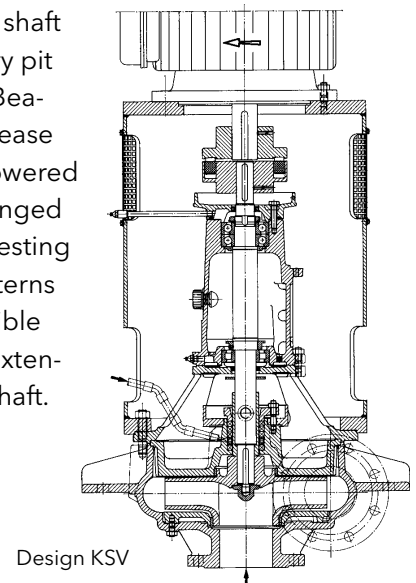

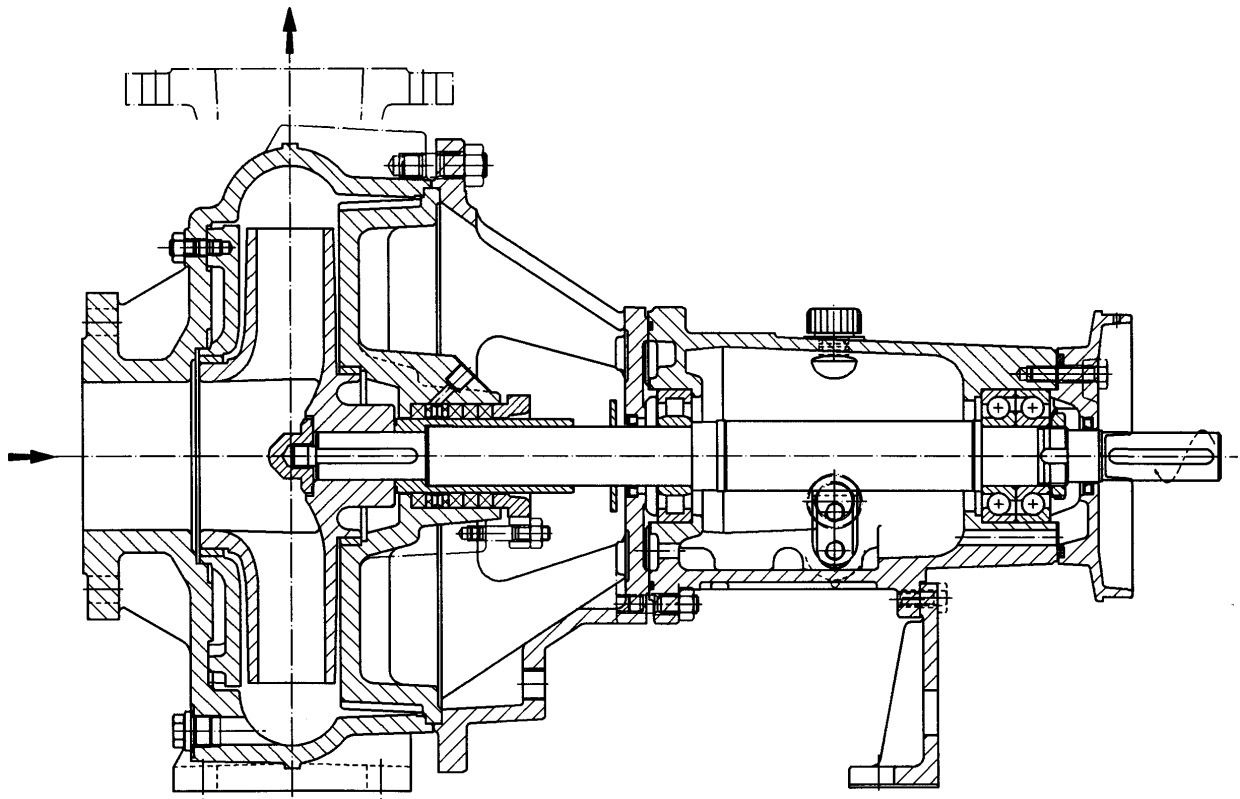

Design features KS:

- Horizontal pump with closed two channel type impeller.
- Wear plate at suction side to protect the casing.
- Casing wear ring optionally available.
- Easy maintenance by back pull out design, disassembling of impeller, shaft sealing and bearing frame without mounting suction and discharge pipes and driving motor (spacer type coupling required).
- Oversized shaft and bearing for continuous heavy duty operation.
- Axial thrust bearing (pair of angular contact bearings) at drive side for handling high axial loads in both directions. Roller bearing at pump side.
- Dry shaft design protected by closed impeller nut and shaft sleeve.
- Shaft sealing: stuffing box with external flush or mechanical seals acc. to EN 12756 (DIN 24960), single mechanical seal internally arranged or double seal arrangements.

Design W

Technical Data

Performance Range:

- Capacity up to 900m³/h (3900USgpm)
- Head up to 60m (200feet)
- Speed up to 1450rpm

Sizes:

- DN 100 up to DN 200 (4" up to 8") discharge

Temperature:

- max. 120°C (250°F)

Casing pressure:

- max. 10bar (145psig)

Liquids:

- Contaminated liquids with solids and fibres
- Unscreened waste water, sludge up 10% atro
- Crystalline suspensions, effluent, etc.
- Paper pulp, cekkzkise

Materials:

Code	Impeller	Casing, Casing Cover	Bearing Frame, Lantern	Shaft	Shaft Sleeve
N	Cast iron 0.6025	Cast iron 0.6025	Cast iron 0.6025	Stainless steel 1.4021	Stainless steel 1.4021
NL	Cast iron 0.6025	Ductile iron 0.7040			
VN	Stainless steel 1.4408	Cast iron 0.6025			
VV		Stainless steel 1.4408			Stainless steel 1.4462



Applications:

- Industrial or public waste and sewage plants
- Chemical industry
- Mining
- Sugar mills
- Food processing
- Pulp and paper mills

Other materials and special versions upon request

Performance Range 1450rpm

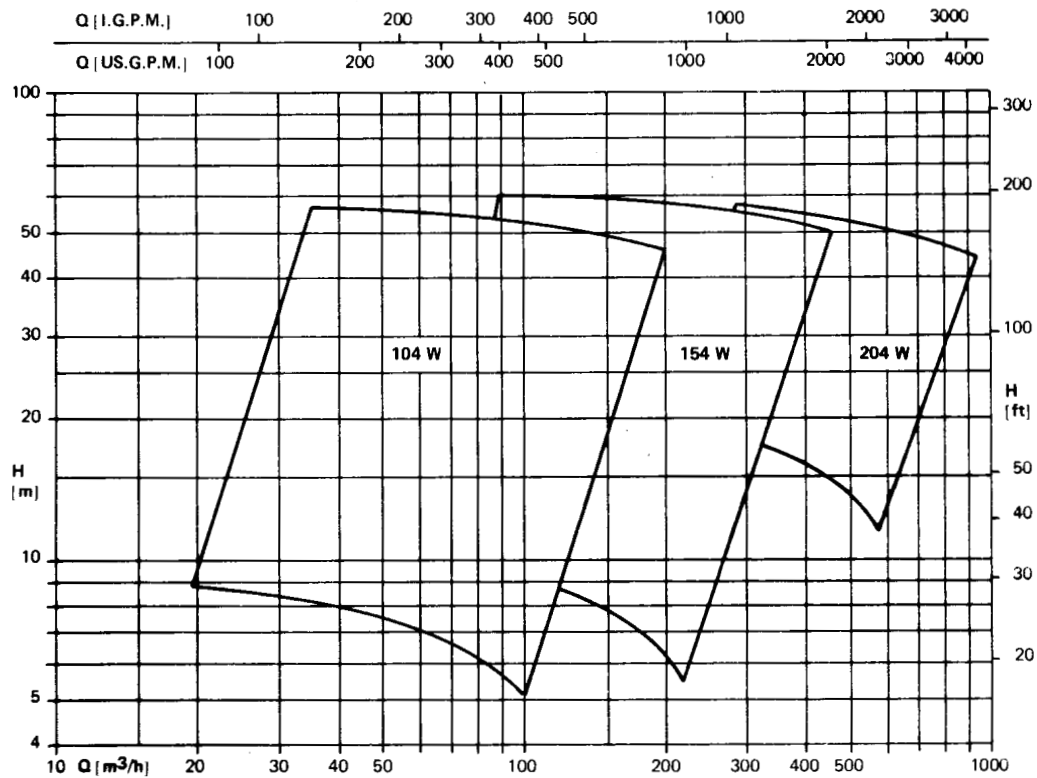

Performance Range 950rpm

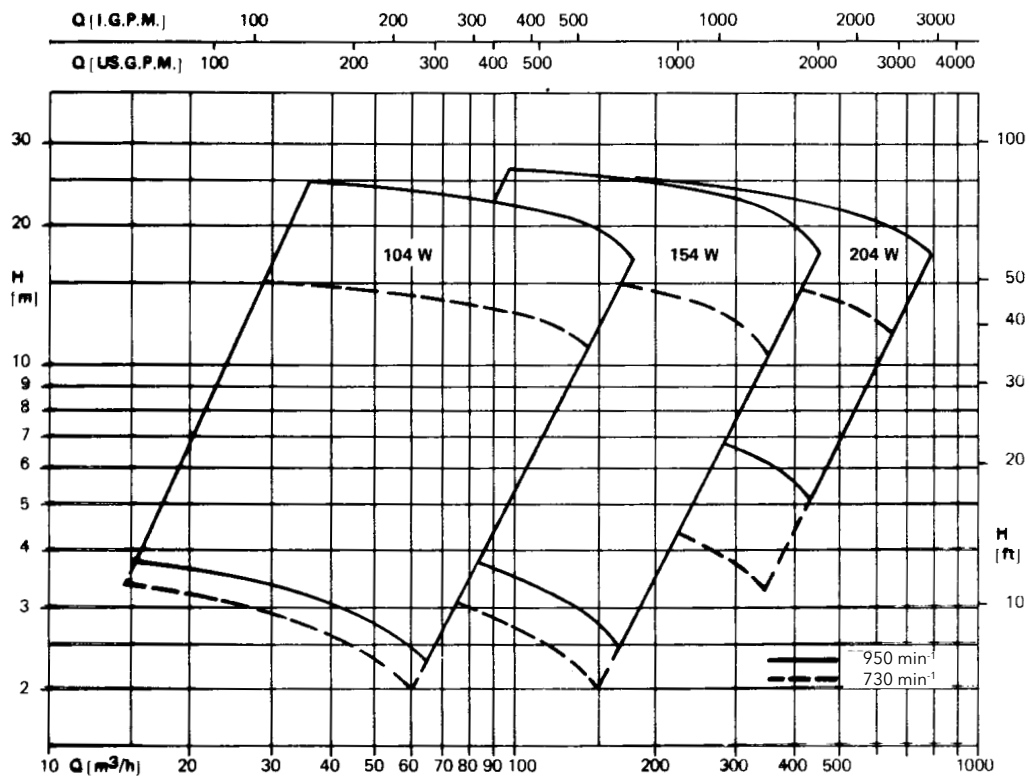

Design Versions

Design W:

Horizontal pump with vortex type impeller and oil lubricated bearing frame. Easy maintenance by back pull out system, disassembling of impeller and bearing frame without mounting suction and discharge pipes and driving motor (spacer type coupling required). Suction branch axial, discharge branch vertically upwards.

Electric drive by flexible coupling, pump and motor mounted on common base plate. Optional V-belt drive, reverse overhead mounted (huckepack design).

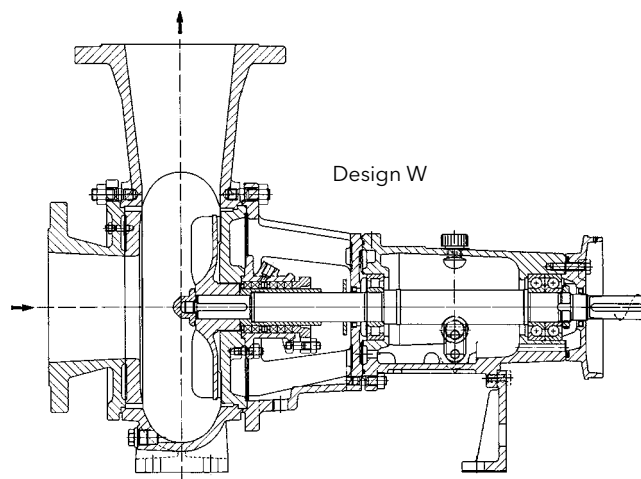

Design WV:

Vertical short shaft version for dry installation. Bearing frame grease lubricated powered by vertical flanged IEC motor resting on motor lantern either by flexible coupling or extended cardan shaft.

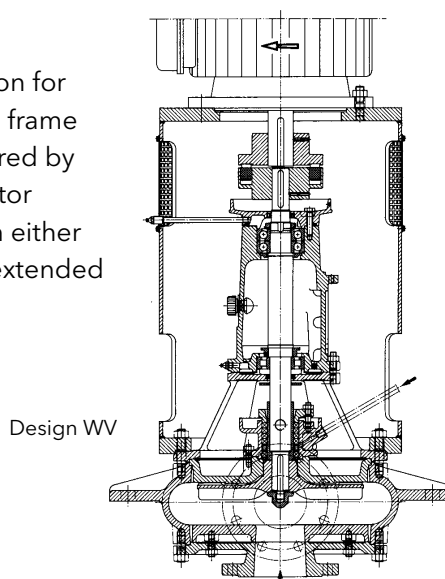

Design WT:

Vertical line shaft version for wet or dry installation. Drive head with motor lantern arranged above pump sump or pump floor. Radial bearings, sleeve bearing arranged in the column pipe. Lubrication by clean water.

Installation length up to 10m.

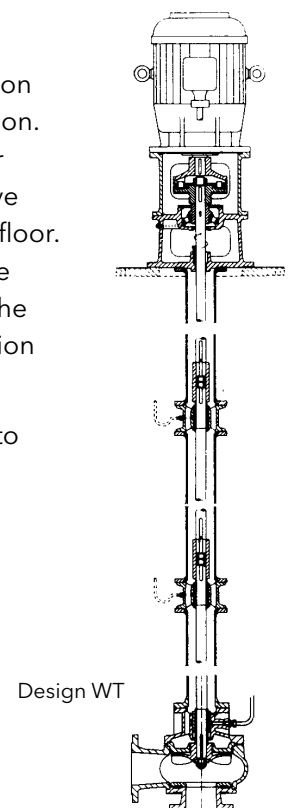

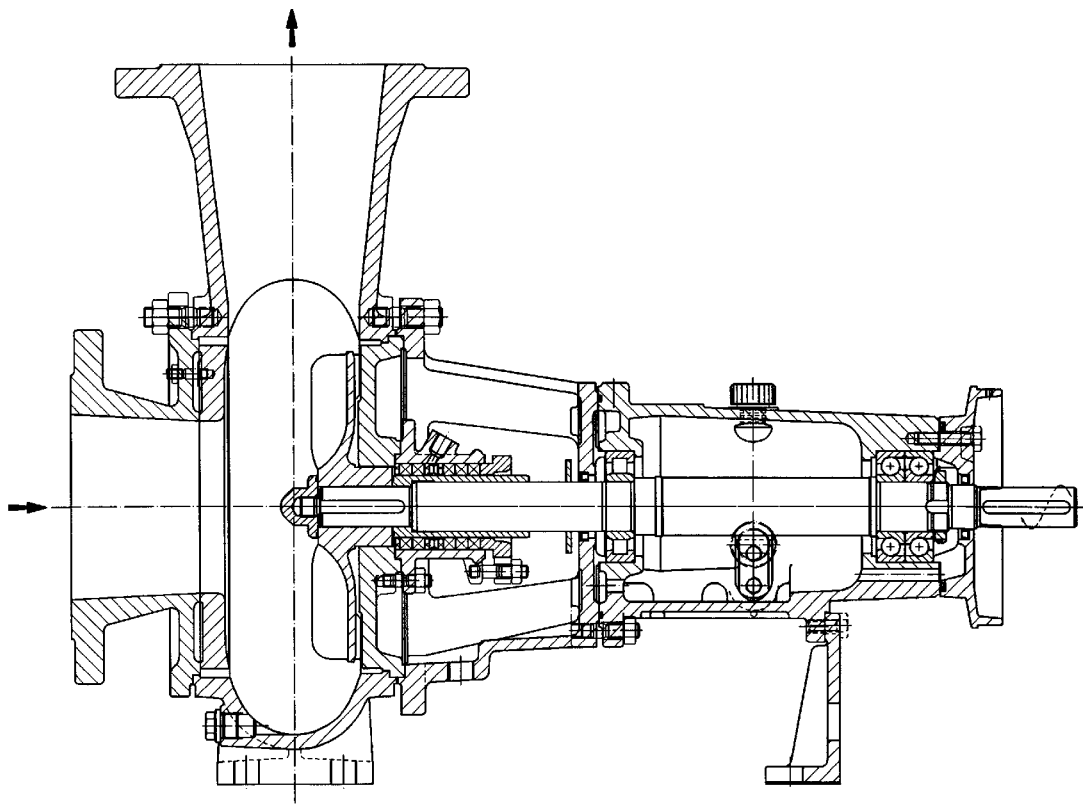

Design features W

- Horizontal pump with vortex type impeller, clogless, large free passage for handling liquids containing solids and fibres.
- Easy maintenance by back pull out design, disassembling of impeller, shaft sealing and bearing frame without mounting suction and discharge pipes and driving motor (spacer type coupling required).
- Oversized shaft and bearing for continuous heavy duty operation.
- Axial thrust bearing (pair of angular contact bearings) at drive side for handling high axial loads in both directions. Roller bearing at pump side.
- Dry shaft design protected by closed impeller nut and shaft sleeve.
- Shaft sealing: stuffing box with external flush or mechanical seals acc. to EN 12756 (DIN 24960), single mechanical seal internally arranged or double seal arrangements.

Design WTS

Technical Data

Performance Range:

- Capacity up to 190m³/h (840USgpm)
- Head up to 20m (65feet)
- Speed up to 1450rpm

Sizes:

- DN 100 (4") discharge

Temperature:

- max. 95°C (200°F)

Design:

Vertical line shaft pump with vortex type impeller. Drive head with motor lantern arranged above pump sump. Radial bearings, sleeve bearings arranged in the column pipe (Bronze bushes and stainl. steel sleeves) lubricated by handled liquid or optional by external clean water.

Discharge connection above pit cover.

Standard length to fit into pits of 1000, 1500, 2000, 2500, 3000 or 3500mm depth when allowing a distance of 100mm between pump suction and pit bottom.

Liquids:

Clean and/or contaminated liquids containing solids and fibres.

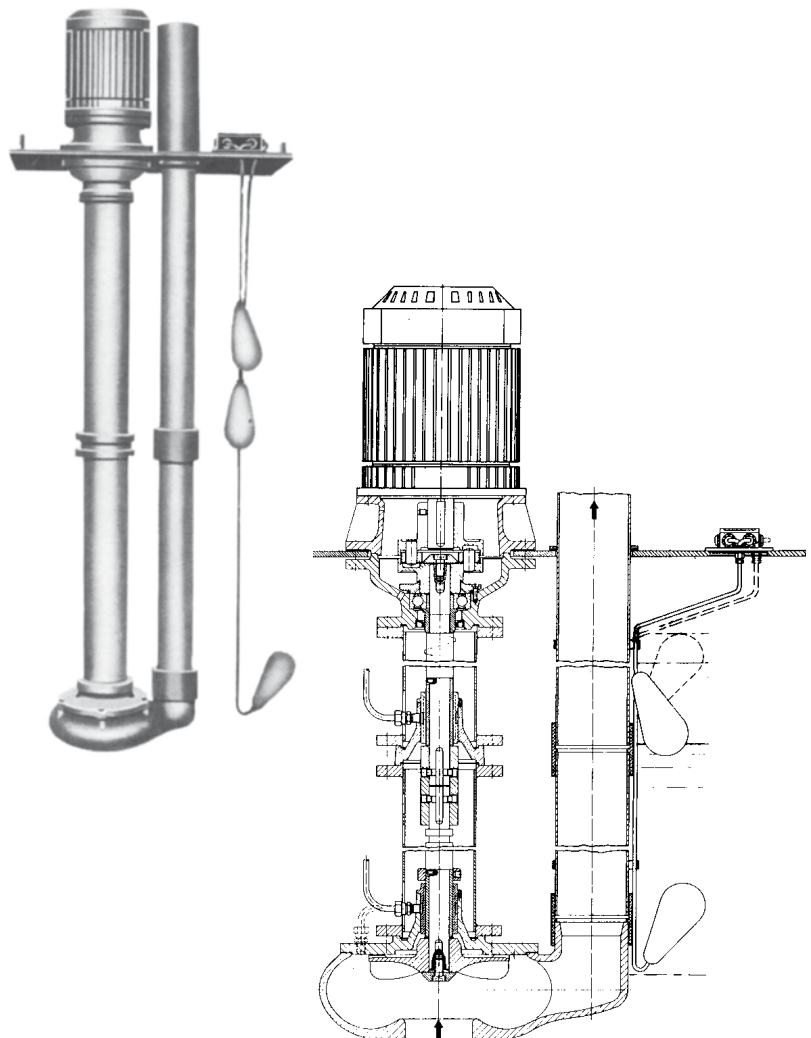

Applications:

Clogless dewatering of waste water pits in industry as sugar mills, food processing, paper mills, power stations, etc.

Materials:

Impeller and casing cast iron 0.6025.

Shaft and sleeve stainl. steel 1.4021.

Bearing bushes bronze G-CuSn16

Other materials upon request.

Performance Range

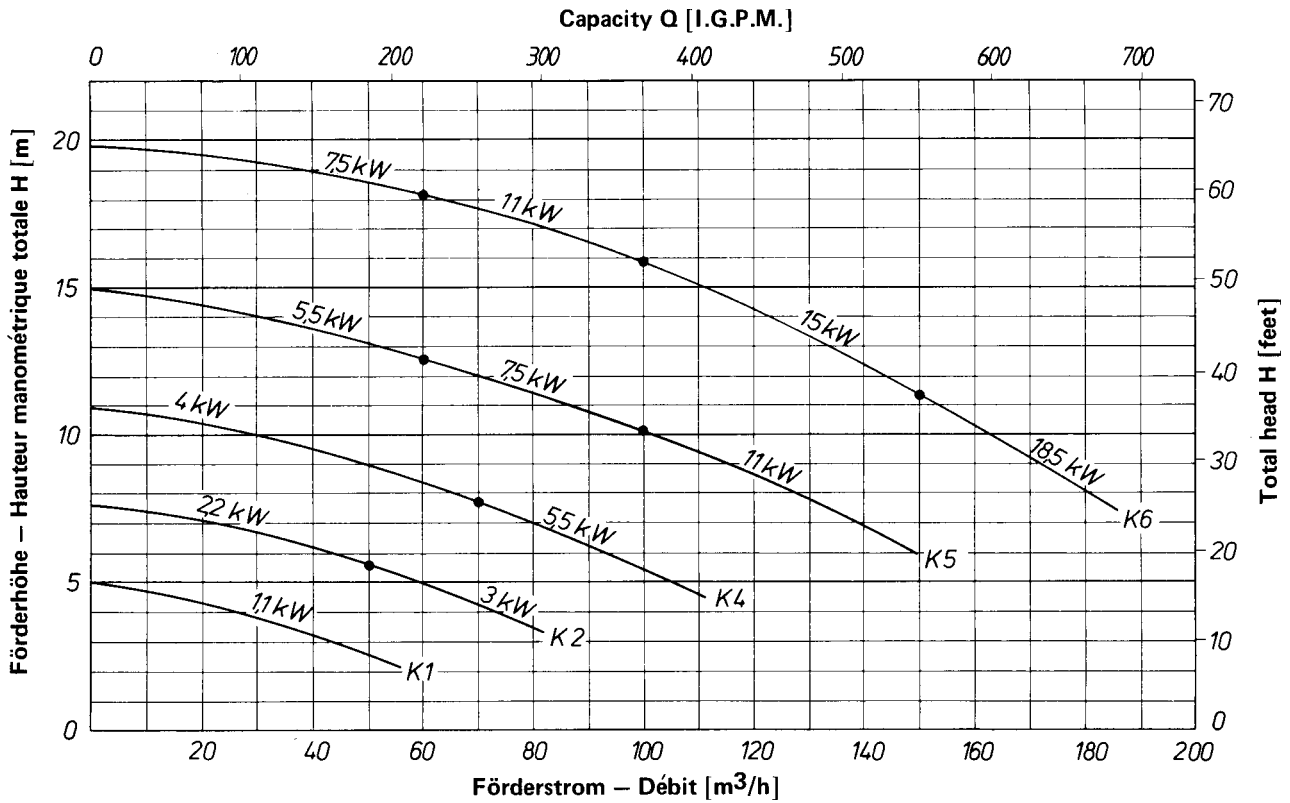

Pump type

Installation length 900 mm	21 . WTS 18	22 . WTS 15	24 . WTS 18	25 . WTS 20	26 . WTS 23							
Installation length 1400 mm	31 . WTS 18	32 . WTS 15	34 . WTS 18	35 . WTS 20	36 . WTS 23							
Installation length 1900 mm	41 . WTS 18	42 . WTS 15	44 . WTS 18	45 . WTS 20	46 . WTS 23							
Installation length 2400 mm	51 . WTS 18	52 . WTS 15	54 . WTS 18	55 . WTS 20	56 . WTS 23							
Installation length 2900 mm	61 . WTS 18	62 . WTS 15	64 . WTS 18	65 . WTS 20	66 . WTS 23							
Installation length 3400 mm	71 . WTS 18	72 . WTS 15	74 . WTS 18	75 . WTS 20	76 . WTS 23							
Curve	K 1		K 2		K 4		K 5		K 6			
Speed ca. rpm	910		1420		1430		1450		1450	1460		
Motor power kW	1,1	2,2	3,0	4,0	5,5	5,5	7,5	11	7,5	11	15	18,5
Current at 400V ca. Amp.	3,12	4,83	6,58	8,7	11,5	11,5	15,3	23	15,3	23	30	38

Naming:

211 WTS 18 E 116
 212 WTS 18 E 116
 213 WTS 18 E 116

Version with internal lubrication by handled liquid
 Version with external clean water lubrication
 Version with external lubrication by grease

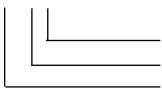

Number of poles (e.g. 6 stands for 930rpm)
 Motor power in 1/10kW
 Standard shaft sealing