

## Submersible sludge pump SP 20

50 Hz

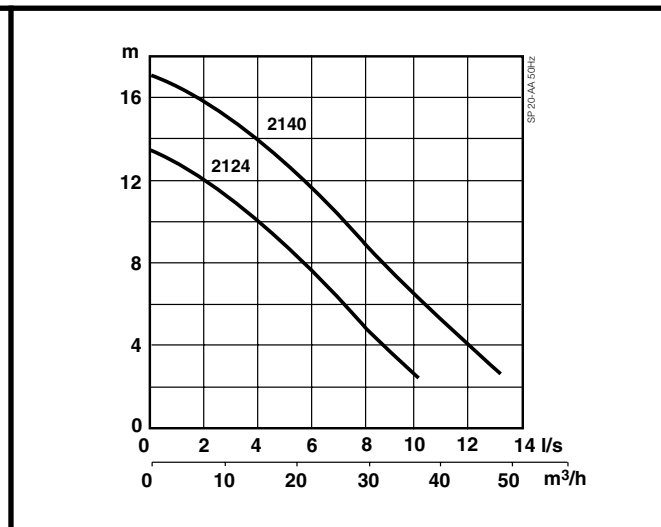
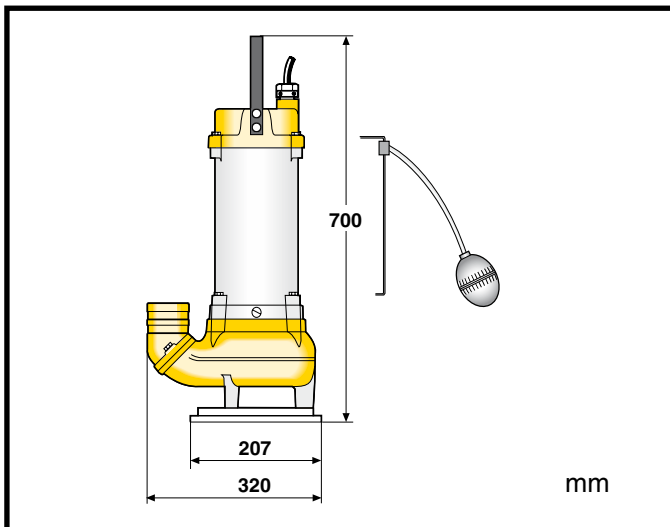

### Specification

Electric submersible pump.  
Maximum submergence: 20 m. Protection class IP 68.  
Max temperature of pumped medium at max power input and continuous duty 40°C.  
Max medium density 1100 kg/m<sup>3</sup>. pH of the pumped medium 5-8.  
Volute with free passage Ø 60 mm. Max no. of starts 30/hour.  
Max impeller diameter requires half motor or more submersed for continuous duty. (Pump can operate lying down.)

### Pump Types

SP 20-2124\*/-2140      3-phase  
SP 20A-2124\*/-2140    3-phase (built-in float switch, excl. 500V)

\* Impeller diameter for duty with low water level or intermittent dry running.

### Electric Motor

3-phase squirrel-cage induction motor, 50Hz.  
Service factor 1.1. Class F insulation.  
Max. power input P<sub>1</sub>: 2.4 kW. Motor rating P<sub>2</sub>: 2.0 kW.  
Speed: 2870 rpm  
D.O.L. start with built-in contactor

Voltage, V	230	400	500
Nominal current, A	7.3	4.2	3.4

### Power Cable

20 m type S1BN8-F (standard cable):  
4 x 1.5 sq.mm.

20 m NSSHÖU.../3E (heavy duty cable):  
3x1.5+3x1.5/3E (230-500V)

### Motor Protection

Built-in thermal switches in the stator windings (140°C, ±5),  
connected to built-in contactor.

### Shaft Seal

Double mechanical seal in oil bath..

Primary seal:            Silicon carbide on silicon carbide  
Secondary seal:        Stainless steel on antimony treated carbon

### Bearings

Upper bearing:        Single-row deep groove ball bearing  
Lower bearing:        Double angular contact ball bearing

### Materials

		EN	ASTM
Motor housing:	Aluminium	EN 1706: AC-43100	ASTM AISi10mg
Handle, fasteners:	Stainless steel	10088: X5CrNi18-10 (1.4301)	AISI 304
Rotor shaft:	Stainless steel	10088: X20Cr13 (1.4021)	AISI 420
Volute, impeller:	Nodular cast iron	1563: ENGJS-HB150	ASTM A 536-80: 60-40-18
O-rings:	Nitrile rubber		

### Discharge Connections

2 ½", 3" (standard), 4" hose connections  
2 ½", 3", 4" B.S.P. threaded connections

### Weight (without cable)

29 kg

### Options and Accessories

Zinc anodes. Surface protection coating  
Electronic motor supervision. Starter and control units.  
Automatic level control unit. PumpFloater. Service kit  
Discharge connection accessories and hose

SP20.02.1007.Eng50Hz  
The manufacturer reserves the right to alter performance, specifications or design without notice.

