

Submersible sludge pump SP 50

50 Hz

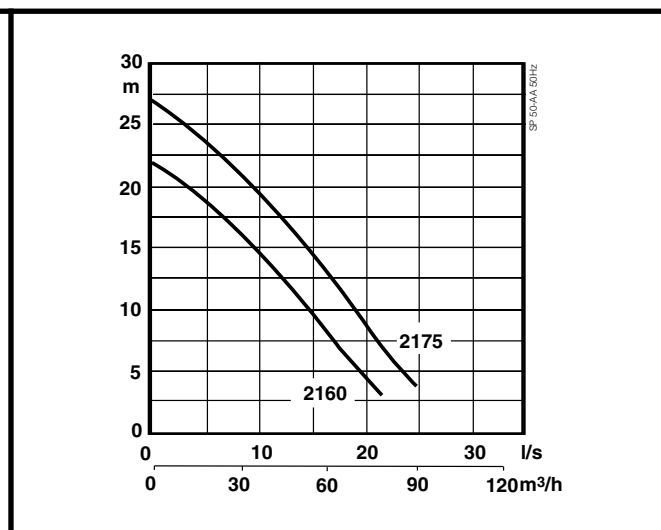
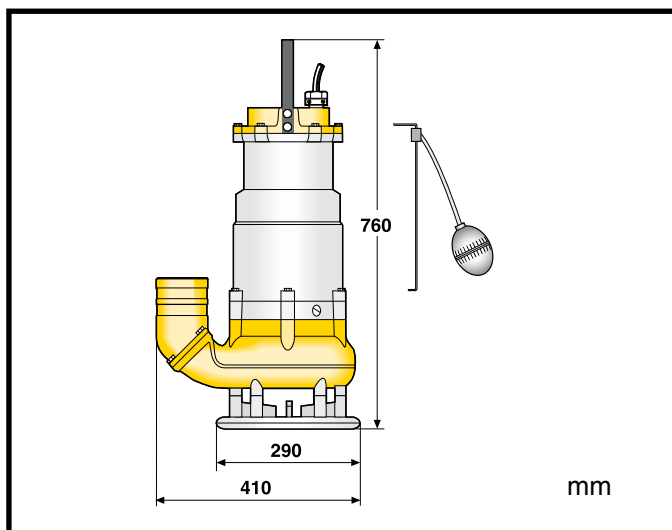

SP50.02.1007.Eng50Hz
The manufacturer reserves the right to alter performance, specifications or design without notice.

Specification

Electric submersible pump.
Maximum submergence: 20 m. Protection class IP 68.
Max temperature of pumped medium at max power input and continuous duty 40°C.
Max medium density 1100 kg/m³. pH of the pumped medium 5-8.
Volute with free passage Ø 65 mm. Max no. of starts 30/hour.
Max impeller diameter requires half motor or more submersed for continuous duty. (Pump can operate lying down.)

Pump Types

SP 50-2160*/-2175 3-phase
SP 50A-2160*/-2175 3-phase (built-in float switch, excl. 500V)

* Impeller diameter for duty with low water level or intermittent dry running.

Electric Motor

3-phase squirrel-cage induction motor, 50Hz.
Service factor 1.1. Class F insulation.
Max. power input P₁: 6.2 kW. Motor rating P₂: 5.2 kW.
Speed: 2850 rpm

Voltage, V	230	400	500
Nominal current, A	19.1	11	8.4

Starting Method

D.O.L. start with built-in contactor.
D.O.L. start with built-in SoftDrive (400-460V).
When used with VFD, pump must be equipped with terminal block instead of contactor.

Power Cable

20 m type S1BN8-F (standard cable):
4 x 2.5 sq.mm (230-500V)
20 m type NSSHÖU.../3E (heavy duty cable):
3x1.5+3x1.5/3E (230-500V)

Motor Protection

Built-in thermal switches in the stator windings (140°C, ±5), connected to built-in contactor.

Shaft Seal

Double mechanical seal in oil bath.
Primary seal: Silicon carbide on silicon carbide
Secondary seal: Stainless steel on antimony treated carbon

Bearings

Upper bearing: Single-row deep groove ball bearing
Lower bearing: Double angular contact ball bearing

Materials

		EN	ASTM
Motor housing:	Aluminium	EN 1706: AC-43100	ASTM AISi10mg
Handle, fasteners:	Stainless steel	10088: X5CrNi18-10 (1.4301)	AISI 304
Rotor shaft:	Stainless steel	10088: X20Cr13 (1.4021)	AISI 420
Volute, impeller:	Nodular cast iron	1563: ENGJS-HB150	ASTM A 536-80: 60-40-18
O-rings:	Nitrile rubber		

Discharge Connections

3", 4" (standard) hose connections
3", 4" B.S.P. threaded connections

Weight (without cable)

54 kg

Options and Accessories

Zinc anodes. Surface protection coating
Electronic motor supervision. Starter and control units.
Automatic level control unit. PumpFloater. Service kit
Discharge connection accessories and hose

