

Submersible sludge pump **SK 81H**

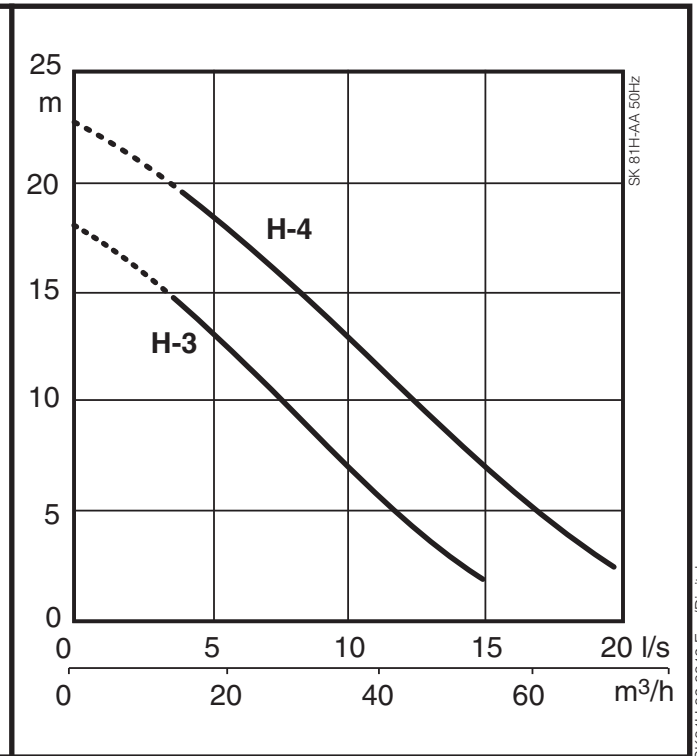
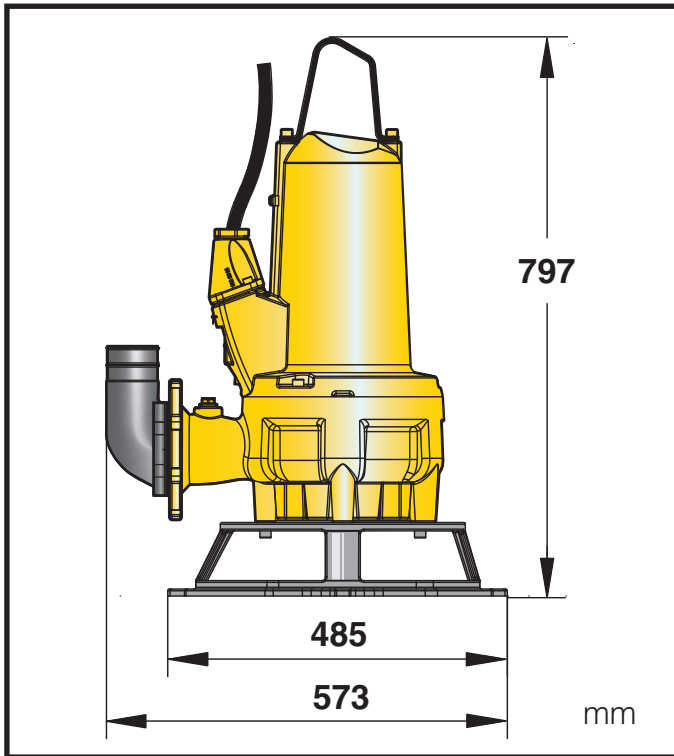

SK81H.02.0912.Eng/Digital
 The manufacturer reserves the right to alter performance, specifications or design without notice.

Specification

Electric submersible sludge pump with a robust ductile iron stand and vortex hydraulic. Free passage 50 mm. Protection class IP 68. Stator insulation Class H. Explosion-proof standard II 2G Ex d IIB T4 (ATEX). Maximum submergence: 20 m.

Pump Types

SK 81H-3 3-Phase
 SK 81H-4 3-Phase

Electric Motor

Premium Efficiency, 3-phase, 2-pole, squirrel-cage induction motor, 50 Hz.

Motor rating P_2 : 3.0 kW (H-3)
 4.0 kW (H-4)

Speed: 2895 rpm (H-3)
 2900 rpm (H-4)

Voltage, V	230	400	500
Nominal current, A (3.0kW)	9.7	5.6	4.5
Nominal current, A (4.0kW)	12.9	7.4	5.9

Power Cable

Length: 20 m
 Type: S1BN8-F
 Size: 7G1.5 sq.mm. (H-3)
 10G1.5 sq.mm. (H-4)

Motor Protection

Built-in thermal overload sensors. Leakage sensor in the seal chamber indicating presence of water.

Cooling System

Self-cooling.

Shaft Seal

Double mechanical seals.

Primary seal: Silicon carbide on silicon carbide
 Secondary seal: Silicon carbide on carbon

Bearings

Upper bearing: Single-row deep groove ball bearing
 Lower bearing: Double angular contact ball bearing

Materials

	EN	ASTM
Motor housing:	Cast iron EN-GJL-250	ASTM A48 35B / 40B
Fasteners:	Stainless steel 10088:X5CrNi-Mo17-12-2 (1.4401)	AISI 316
Rotor shaft:	Stainless steel 10088:X20Cr13 (1.4021)	AISI 420
Volute and impeller:	Cast iron EN-GJL-250	ASTM A48 35B / 40B
Stand:	Nodular cast iron 1563 EN GJS-400-18	ASTM A 536-80: 60-40-18

Discharge Connections

Volute DN 80, 3" hose, G 3" thread

Weight (without cable)

134 kg (H-3), 139 kg (H-4)

Options and Accessories

Starter box for DOL-start.
 Automatic level control box.
 Zinc anodes.

