

Submersible sludge pump SK 150N

50 Hz

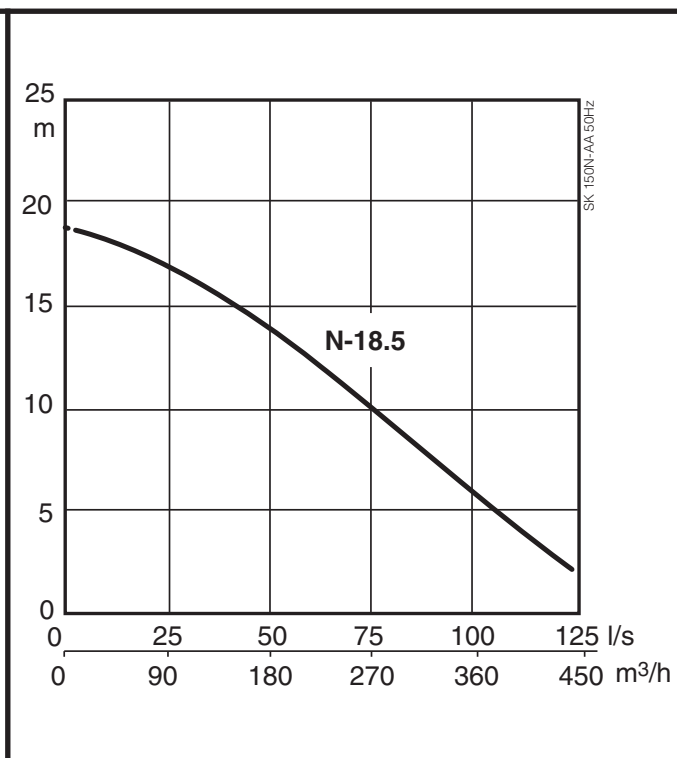
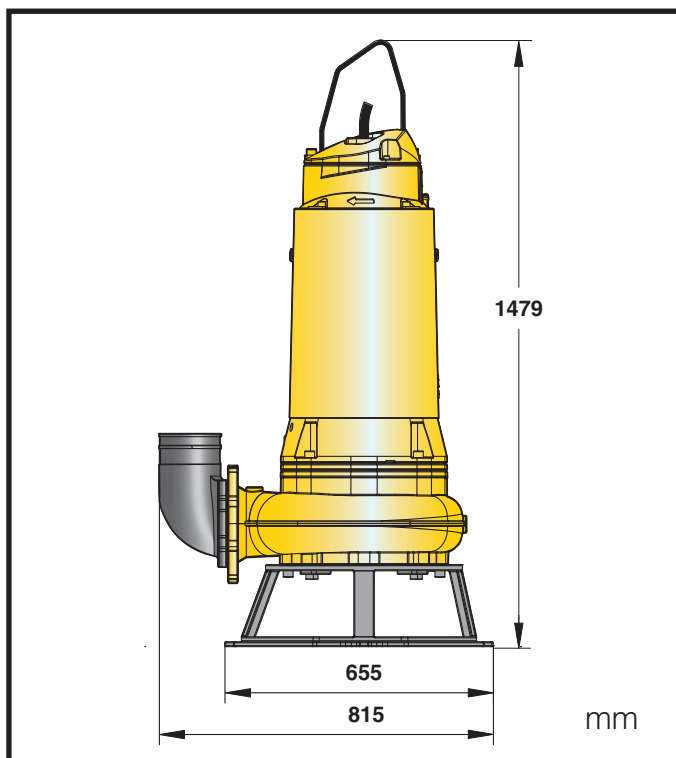

SK 150N.02.0912.Eng/Digital
The manufacturer reserves the right to alter performance, specifications or design without notice.

Specification

Electric submersible sludge pump with a robust ductile iron stand and vortex hydraulic. Free passage 100 mm. Protection class IP 68. Stator insulation Class H. Explosion-proof standard II 2G Ex d IIB T4 (ATEX). Maximum submergence: 20 m.

Pump Types

SK 150N-18.5 3-Phase

Electric Motor

Premium Efficiency, 3-phase, 4-pole, squirrel-cage induction motor, 50 Hz.

Motor rating P_2 : 18.5 kW

Speed: 1465 rpm

Voltage, V	230	400	500
Nominal current, A	64.1	36.9	29.5

Power Cable

Length: 20 m

Type: S1BN8-F

Size: 10G2.5 sq.mm.

Motor Protection

Built-in thermal overload sensors. Leakage sensor in the dry chamber indicating presence of water.

Cooling System

Closed cooling system using water mixed with Glycol (30%).

Shaft Seal

Double mechanical seals.

Primary seal: Silicon carbide on silicon carbide

Secondary seal: Silicon carbide on carbon

Bearings

Upper bearing: Single-row deep groove ball bearing

Lower bearing: Double angular contact ball bearing

Materials

	EN	ASTM
Motor housing:	Cast iron EN-GJL-250	ASTM A48 35B / 40B
Fasteners:	Stainless steel 10088:X5CrNi-Mo17-12-2 (1.4401)	AISI 316
Rotor shaft:	Stainless steel 10088:X20Cr13 (1.4021)	AISI 420
Volute and impeller:	Cast iron EN-GJL-250	ASTM A48 35B / 40B
Stand:	Nodular cast iron 1563 EN GJS-400-18	ASTM A 536-80: 60-40-18

Discharge Connections

Volute DN 150, 6" hose, G 6" thread

Weight (without cable)

475 kg

Options and Accessories

Starter box for DOL-start.

Automatic level control box.

Zinc anodes.

