

Grinding Systems

Product Overview, Technology and Application Areas

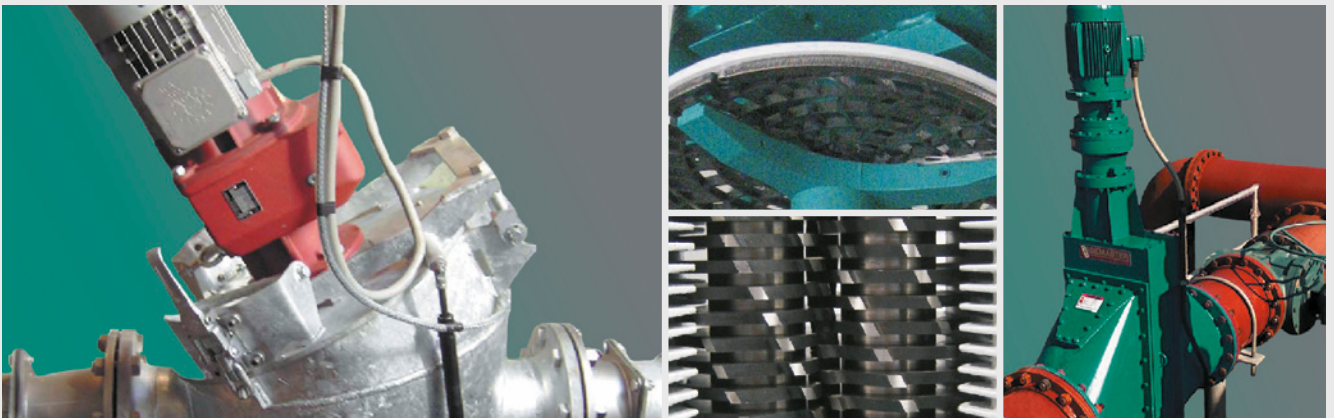

NETZSCH Pumps & Systems – Solutions you can trust ■

Grinding Systems

Universal Use

NETZSCH grinding systems are used to effectively protect your complete installation including the pumping equipment. They ensure that oversize solids are reliably reduced to a pumpable size therefore safely avoiding the danger of blockages.

NETZSCH conditioners and macerators are designed for the most arduous of industrial applications to prevent pipe blockage and damage to downstream equipment by reliably reducing the size of solid matter in pumped media.

The extensive selection of macerating systems provides an ideal solution for many industries and processes.

The robust design of the NETZSCH grinding systems ensures a high performance coupled with trouble free operation.

Advantages

- Low running costs through high operating efficiency
- High operational reliability
- Simple maintenance
- Comprehensive range of accessories is available for almost every application
- Worldwide service network and weekend emergency support

Primary Applications

- Waste water treatment
- Agriculture
- Slaughterhouses and recycling plants
- Canning/tinning factories
- Industrial kitchens
- Sugar factories



The Right Model for Every Application

NETZSCH Cutting Plate Macerator M-Ovas®

The special shape of the housing directs solid particles in the waste water towards the cutting plate, where they are held and chopped by the rotating blades.

NETZSCH Twin Shaft Macerator Taskmaster®

The NETZSCH twin shaft macerator has been designed for applications where the medium contains large solid objects. Dependent on the size reduction requirements there is a choice of different tooth and spacer plates with combinations.

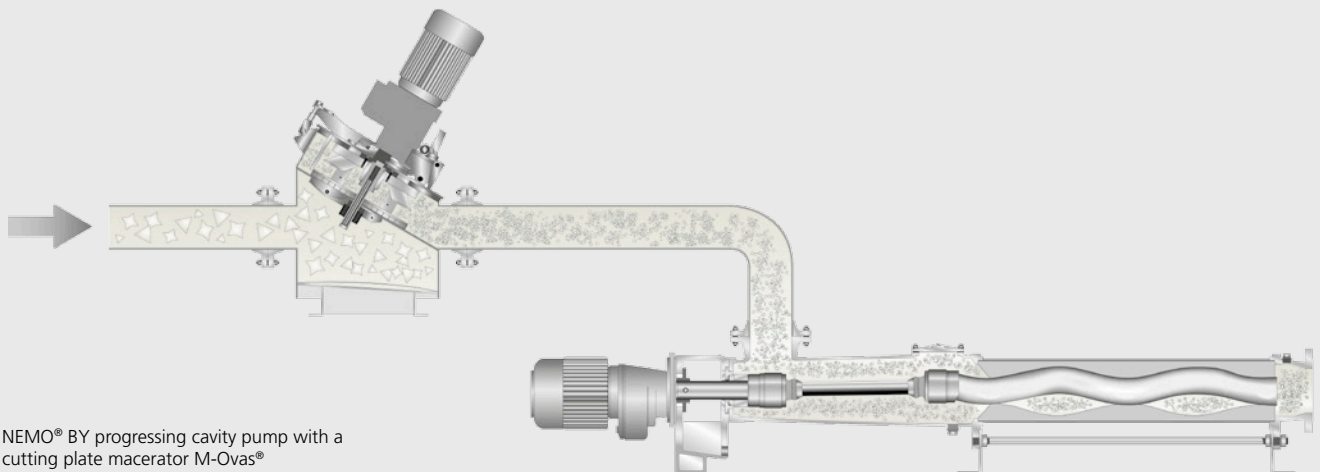

NEMO® BY progressing cavity pump with a cutting plate macerator M-Ovas®

Cutting Plate Macerator M-Ovas®

Features and Construction

The NETZSCH M-Ovas® is particularly useful in all industries, where particles in the medium endanger process reliability. All solids in the medium are reliably macerated to prevent pipework and downstream equipment from blocking.

High Delivery Capacities

- Flow capacities up to 300 m³/h of waste water and sludge with up to 7 % dry solids content
- Two sizes of model available depending on the flow rate

Wide Range of Applications

The NETZSCH M-Ovas® is particularly suitable for the use in the following industries:

- Sewage and waste water treatment
- Biogas plants
- Abattoirs
- Organic biological waste recycling plants
- Rendering plants
- Paper and pulp production
- Agriculture
- Sugar factories
- Leather production
- Spas and health resorts

Advantages

- Compact design for high flow rates
- Easy and fast disassembly of cutting plate and blade units
- Low energy demand at high flow rates
- Integrated stone trap with separate clean-out and drain ports
- Easy access allows simple disposal of the sediment
- Self-adjusting blades reduce maintenance and ensure optimal cutting performance
- Sealing by means of a mechanical seal with oil quench
- Easy to maintain

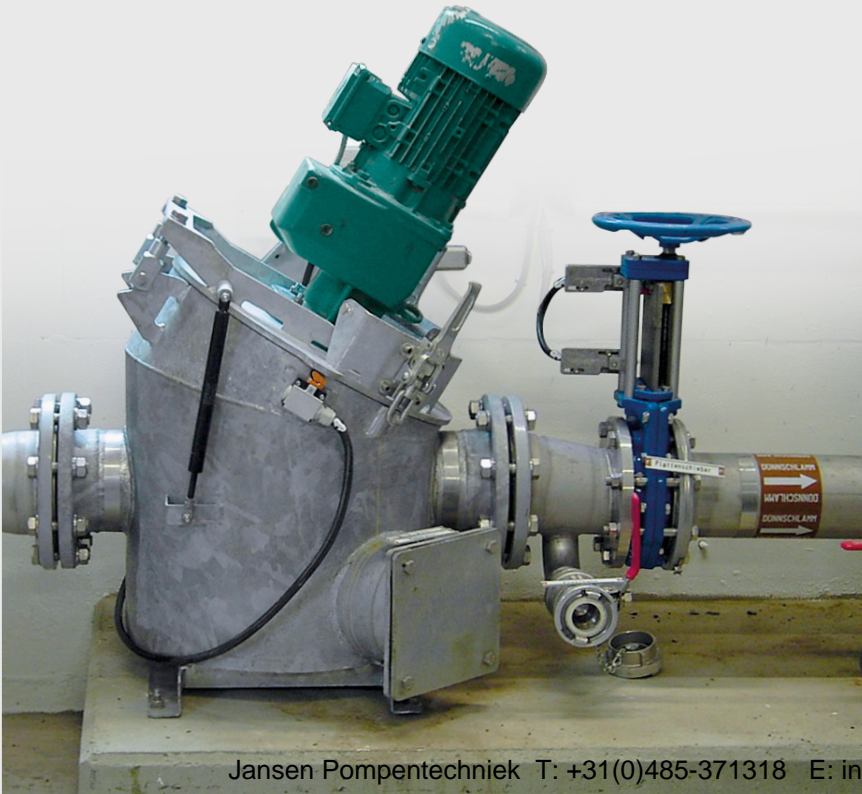

1 Housing

A hydrodynamic design with integrated stone trap for solids, with a clean-out port. The sediment can easily be removed by opening the cover plate. The housing is galvanized to ensure corrosion resistance. Available in stainless steel (optional).

2 Housing Cover

Cutting unit integrated into housing cover. A gas strut is fitted to the cover to assist opening. This allows for easy cleaning of solids in the stone trap.

3 Cutting Unit

Cutting plate of wear resistant, hardened steel. Optimum cutting performance through a cutting unit with self-adjusting blade mechanism. Blades made from wear resistant hardened steel. The flywheel effect of the cutter head reduces the installed power. Easy exchange of cutting plate and cutting blades without the necessity to disassemble the pipework.

4 Shaft Seal

Hard metal faced mechanical seal with oil quench to prevent product leakage.

5 Drive

The standard drive unit has reinforced bearings.

6 In-line Version

Product inlet and outlet are positioned on the same level. The NETZSCH M-Ovas® can be directly connected to a horizontal pipeline or to a NEMO® pump inlet where flange is set at 90°.

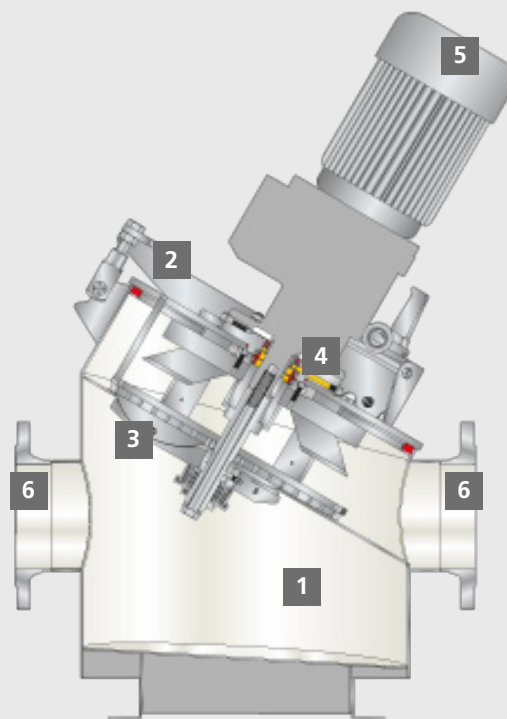

Twin Shaft Macerator Taskmaster®

Features and Construction

For applications with particularly chunky and sturdy solids in the waste water flow the NETZSCH Taskmaster® is needed.

The robust design of the NETZSCH Taskmaster® ensures a high performance coupled with trouble free operation. It offers the best performance even under the most arduous of operating conditions. The twin shaft macerator

provides a free flow through, protecting the pumps and other plant equipment. Depending on the application one of five different models and sizes can be installed. Through the different, very low number of revolutions of the shafts the NETZSCH twin shaft macerator offers the option of self cleaning. Low power drives can be used even on high throughput applications.

Wide Range of Applications

The NETZSCH Taskmaster® is particularly suitable for the use in the following industries:

- Waste water treatment
- Agriculture
- Slaughterhouses and recycling plants
- Canning/tinning factories
- Industrial kitchens
- Sugar factories

Advantages

- Optimized cost performance ratio
- Low running costs through highest efficiency
- Cartridge design cutter assemblies allow simple and quick maintenance providing high operational safety
- Through the different, very low number of revolutions of the shafts the NETZSCH twin shaft macerator offers the option of self cleaning
- Robust design, trouble free operation, high performance

High Delivery Capacities

Capacities up to 300 m³/h with a solids content rate of up to 10 %



1 Housing

A robust hydrodynamic inline housing which can be directly connected into a pipeline. Also available as channel unit.

2 Cutting unit

High quality blades made of special steel reliably macerate the solids in the medium. The cartridge units comprise of six cutters and six spacing rings. To reach the required particle size, a selection of different blades is available.

3 Shaft Seal

The shaft is sealed with a cartridge type mechanical seal.

4 Bearing

Robust bearings on both ends of the shafts ensure smooth running and prevent the shafts from spreading when especially hard solids are encountered.

5 Lantern

Via an elastic coupling with flange every IEC motor or drive can be accommodated.

6 In-line Version

Product inlet and outlet are positioned on the same level. The NETZSCH twin shaft macerator can be directly connected into a horizontal pipeline or to a pump inlet of a NEMO® pump or a NETZSCH TORNADO® industrial rotary lobe pump, where flange is set at 90°.

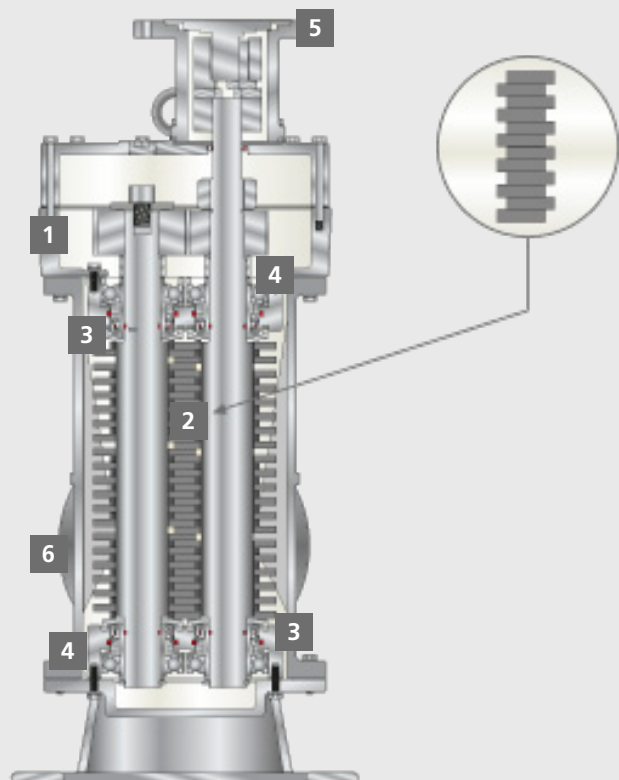

The NETZSCH Group is an owner-managed, internationally operating technology company headquartered in Germany.

The three Business Units – Analyzing & Testing, Grinding & Dispersing and Pumps & Systems – provide tailored solutions for highest-level needs. Over 2,200 employees at 125 sales and production centers in 23 countries across the globe guarantee that expert service is never far from our customers.

The NETZSCH Business Unit Pumps & Systems offers NEMO® progressing cavity pumps, TORNADO® rotary lobe pumps, screw pumps, macerators/grinders, dosing systems and equipment custom built and challenging solutions for different applications on a global base.

NETZSCH Mohnopumpen GmbH
Geretsrieder Straße 1
84478 Waldkraiburg
Germany
Tel.: +49 8638 63-0
Fax: +49 8638 67981
info.nmp@netzsch.com

www.netzsch.com