

Electric Submersible Sewage Pumps Range AK



Discharge Size
4" - 20"

Innovation in Hydraulic Performance

High Performance in Waste Water Pumping



HOMA submersible waste water and sewage pumps operate worldwide in numerous kinds of domestic, municipal and industrial applications. Decades of experience in the design and manufacturing of submersible pumps plus uncompromising attention to quality in every detail and strict monitoring of production quality ensure the utmost reliability and long service life of all **HOMA** products.

Flexible system-components for problem-free installation

HOMA combines efficiency, safety, high quality and robust design with a flexibility that allows the individual optimization of every project realization: Pumps for various types of application and installation, a complete program of installation equipment including pipes, valves, pump pits from concrete or composite materials, electric control and monitoring systems. With this range **HOMA** can provide a tailor-made solution for every waste water pumping application.

The reliability of fully automatic operation

HOMA waste water pumping stations feature fully automatic control and monitoring. Reliable liquid level control systems of various types (float switch, pneumatic, ultrasound or electronic systems) are available to secure reliable pump operation at minimum energy consumption. All possible fault factors like shaft seal condition, temperatures, moisture or power supply can be automatically monitored and transferred to various alarm systems.

Higher Performance to meet every Challenge

Various challenges – individual solutions:

HOMA submersible wastewater pumps are designed for pumping sewage, sludge, effluents or surface water, including liquids containing a large proportion of solid or fibrous matter. They are installed in domestic, municipal, industrial and agricultural pumping applications.

For chemically aggressive liquids, specific components like impellers, volutes or complete units are also available from high-resistant materials like stainless steel, duplex or bronze.



The right installation for every pump station

Wet well installation with auto-coupling system

Submerged autocoupling guide tube system for automatic connection and disconnection of the pump from the pipework from outside the sump. All maintenance or repair work can be done outside the sump. Back in operating position, the weight of the pump ensures leak-proof discharge connection.

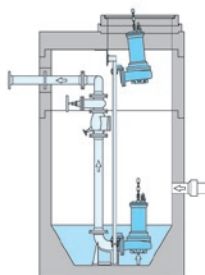

Wet well installation with base stand Operating conditions

Submerged pump mounted on a ring base stand for temporary, service or emergency operation. Discharge connection with pipe or hose.

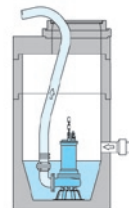

Permanent dry well installation, vertical or horizontal

Flood-proof installation for pump stations with separate collection sump. Fixed flanged connection of suction and discharge pipe.

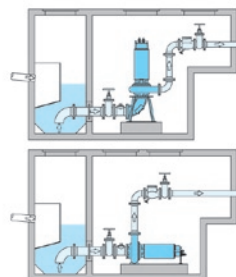

The motors are designed for continuous operating duty (S1) at maximum 15 starts per hour. In addition to a fully submerged motor housing in wet well installation, a jacket cooled motor-variant is available for S1 operating with a non-fully submerged motor or for dry well installation.

Pumps with enclosed two-channel impellers are designed for intermittent operation, normally in automatic levelcontrolled wet or dry well sump installations. They are also suitable for limited continuous operation, as in storm water retention tanks, or for unlimited continuous operation, such as industrial water supply.

Design - Proven Quality in Detail

More quality in design and materials – less maintenance and failures

Quality can be measured – **HOMA** submersible waste water pumps are characterized by the robust design, generous dimensioning and high quality materials of all components.

Materials

Motor housing	ASTM A 48; Cl.40 B ¹⁾
Pump housing	ASTM A 48; Cl.40 B ¹⁾
	ASTM A 395
Impeller	ASTM A 48; Cl.40 B ¹⁾
	ASTM A 395
Wear rings	Bronze / Stainless Steel
Motor shaft	Stainless steel
Mechanical seals	Silicon-carbide / Silicon-carbide
Motor cooling jacket (model U)	Stainless steel
Seals and O-rings	NBR (Perbonane) ³⁾
Cable	H07RN-F (PLUS) ⁴⁾

¹⁾ also available in stainless steel

²⁾ also available in bronze

³⁾ also available from FPM (vitone)

⁴⁾ screened cable on request

1 Discharge
With DIN/ANSI flange 4" up to 20"

2 Non-clogging, high efficiency impellers with large spherical clearance.
Enclosed two channel impeller with replaceable wear ring and large spherical clearance.

3 Shaft seals
Two independently working siliconcarbide mechanical seals in tandemarrangement.

4 Oil chamber
Separate large oil chamber, lubricating and cooling the mechanical seals, forming an extra safety and inspection element. Additional electronic seal condition monitoring probe.

5 Motor
Three-phase electric motors, with 4-, 6-, 8-, 10- or 12-pole motor speed. Insulation class F (155 °C), degree of protection IP 68

Explosion protection

All models available with Factory Mutual (FM) label for Class I, Div 1 Ex construction.

6 Motor cooling
Motors for submerged operation are cooled by the surrounding liquid. For dry well or non-submerged operation, motors are available with a cooling jacket, around the motor. 3 Systems are alternatively available:

- The standard system provides a cooling circulation of water from the pump volute (pump model code: U)
- Option 1 provides a cooling circulation by an external cooling liquid system (fresh water or radiator) trough inlet and outlet connections at the motor jacket (pump model code: UE)
- Option 2 is a closed circuit cooling system with a cooling liquid internally circulating, providing the heat exchange through a contact surface between heat exchange chamber and pump chamber.

7 Thermal sensor (bi-metal)
Embedded in the motor winding. PTC sensors or PT 100 available on request.

8 Moisture monitoring in stator housing
Separate chamber with float monitoring.

9 Shaft bearing
Maintenance-free, prelubricated ball bearings.

10 Temperature monitoring of the shaft bearings
Available on request.

11 Cable junction chamber
Separate junction chamber.

12 Electronic moisture sensor in junction chamber

13 Pressure sealed, strain relief cable entry

14 Anti-condensation heating for cable junction chamber and stator housing available on request

Option 1

External cooling system

inlet and outlet for external cooling liquid supply



Option 2

Closed circuit cooling system

backflow of hot cooling liquid into heat-exchange chamber

inflow of cold cooling liquid into motor jacket chamber

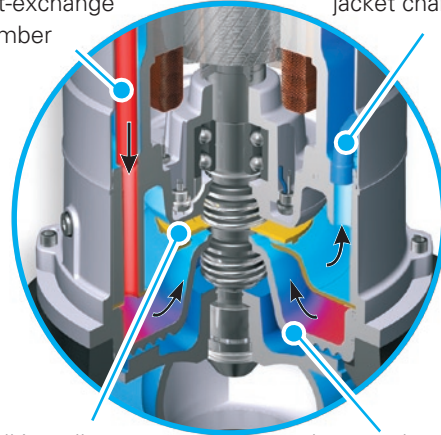

small impeller for pumping the cooling liquid

heat exchange of cooling liquid with cold pumped liquid through pump flange, spiral-shaped for maximum surface

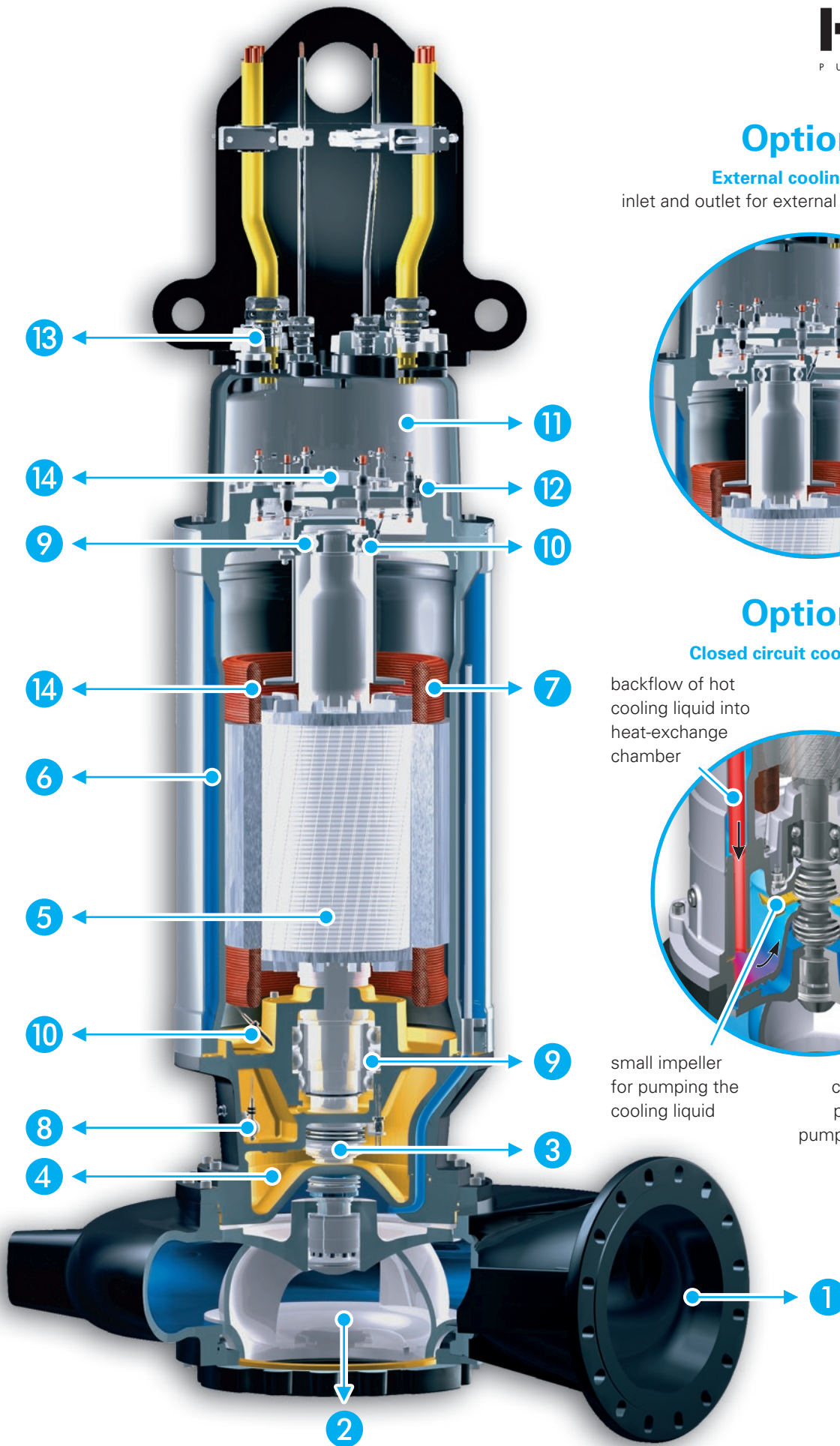

Motor selection

Motor speed:

For the standard hydraulic ranges, the motors are designed with the following speeds:

- 1750 rpm = 4-pole
- 1160 rpm = 6-pole
- 890 rpm = 8-pole
- 710 rpm = 10-pole
- 590 rpm = 12-pole

Voltages:

All specified data relate to an operating voltage of 230 V / 460 V, 3 Ph, 60 Hz. Different voltages are available on request.

Type of starting:

The motors are supplied as standard suitable for Direct- or Star-Delta-Start. All motors are also suitable for operating with frequency converter or soft starter device.

Explosion protection:

In addition to the standard version, all motors are available explosion proof according to Factory Mutual (FM) label for Class I, Div 1.

Dry well variant:

Besides the version for submerged operation, all pumps are also available for dry well or non-submerged operation.

Motor monitoring:

All motors are supplied with temperature sensors in the winding, bi-metallic sensors (standard) or PTC sensors or PT 100 (on request).

- Motors for wet well installation (without cooling jacket):
As C-version (see pump type code) with oil chamber seal condition monitoring probe and moisture sensor in junction chamber)
- Motors with cooling jacket:
Supplied as standard with oil chamber seal condition monitoring probe. S-version additionally with moisture monitoring in the stator housing.
Additional monitoring devices (e. g. bearing temperature) on request.

Hydraulic selection

Discharge and suction flange:

- 4"
- 6"
- 8"
- 10"
- 12"
- 16"
- 20"

Reducing adapters for different autocoupling system and valve dimensions are available.

Enclosed two channel impeller

For liquids containing impurities and sludge with solid particles.

Impeller spherical clearance:

The pumps are available with impeller spherical clearances from 3" to 8" according to pump range.

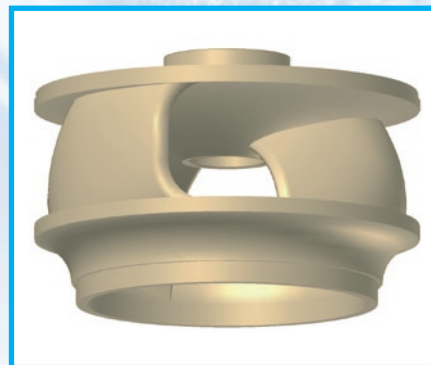

International Customer Service



Worldwide Presence

HOMA pumps are installed in more than 60 countries around the world – in countless projects of various kinds. They comply to all international safety and quality standards and are certified by many institutions and organisations responsible for national waste water treatment standards. To maintain and further develop this high quality level is our main target.

Network of Sales and Service Partners



HOMA provides a worldwide network of agents and distributors supporting our customers with excellent sales and service assistance in planning, specification and selection, including a computer software program available on CD-ROM or from the WorldWideWeb.

HOMA product range

- Submersible waste water pumps with channel- and vortex-hydraulic
- Submersible propeller pumps
- Submersible grinder pumps
- Submersible, surface and venturi aerators
- Packaged pump stations
- Waste water lifting stations
- Submersible drainage pumps
- Contractor pumps
- Submersible mixers and flow generators
- Electric and electronic pump controls



HOMA Pumpenfabrik GmbH
P.O.Box 22 63, D-53814 Neunk.-Seelscheid
Tel. +49 (0) 22 47/702-0, Fax +49 (0) 22 47/702 -44
e-mail: info@homa-pumpen.de
www.homapumps.com