

CARATTERISTICHE - FEATURES**COMPONENTI DELLA POMPA - PUMP COMPONENTS**

- 1 ROTORE - ROTOR**
MATERIALI: AISI 304 / 316, duplex, con possibilità di cromatura, tempra e nitrurazione.
MATERIALS: stainless steel 304 / 316, duplex, nitride steel, hardened steel and chromed steel.
- 2 STATORE - STATOR**
TIPI DI GOMMA: NBR, NBR alimentare, EPDM, EPDM alimentare, VITON.
RUBBER TYPE: NBR, NBR food grade, EPDM, EPDM food grade, VITON.
- 3 SNODO - JOINT**
CROCIERA: AISI 316 con manicotto in gomma NBR, NBR alimentare, EPDM, VITON.
CROSS JOINT: stainless steel 316 with rubber sleeve NBR, NBR foodgrade, EPDM, VITON.
- 4 TENUTA - SEALING**
Tenuta meccanica singola.
Mechanical seal.
- 5 BOCCA ASPIRANTE - SUCTION**
Precamera dove viene aspirato il prodotto. Inox, ghisa o bronzo a seconda della versione.
Pre-chamber where the fluid comes in, made of stainless steel, cast iron or bronze, depending by the version.
- 6 CORPO PREMENTE CON BOCCA DI MANDATA
CASING WITH DELIVERY PART**
Inox, ghisa o bronzo a seconda della versione.
Made of stainless steel, cast iron or bronze depending by the version.
- 7 BY PASS - BY PASS**
Per la versione in ghisa è in lega di ottone o in ferro, per quella in inox è in AISI 304 / 316 (solo su richiesta).
For the cast iron version it is made of brass or iron, for the other version it is in stainless steel 304 / 316 (on request).
- 8 MOTORE - ENGINE**
L'accoppiamento con il motore è in B3 / B14 o con supporto flangiato.
The coupling with the engine is B3 / B14 or with flanged support.

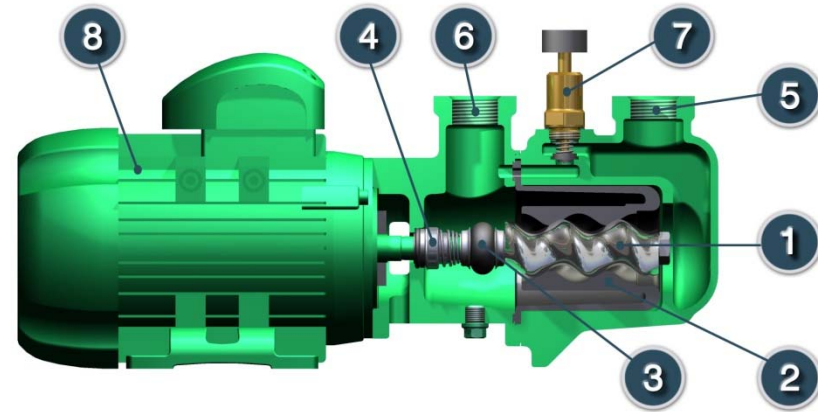

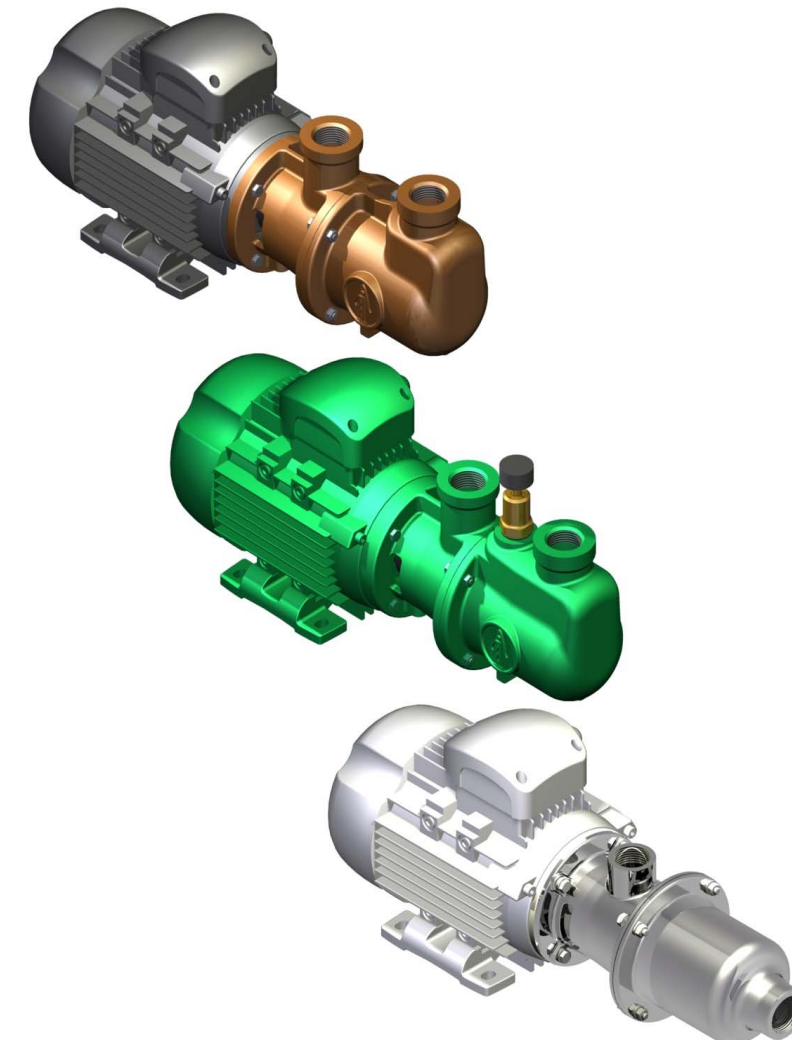

POMPE A STATORE FLOTTANTE – WOBBLE PUMPS

Le pompe serie R, dal design compatto e lineare, hanno un ottimo rapporto prezzo-performance e permettono il pompaggio senza pulsazioni mantenendo inalterato il prodotto. Possono convogliare svariati tipi di liquidi, leggermente abrasivi, viscosi e con piccole parti in sospensione. La versione inox è idonea per fluidi ad uso alimentare, mentre la versione in bronzo per l'uso navale.

R series has compact and linear design, it has a good price-performance ratio and not pulsating flow without jeopardize the physic, chemical and organoleptic characteristics of fluids. The wobble pump is used for many different application, slightly abrasive, viscous or gravel liquids. The st. steel version is particularly suitable for food grade fluids and bronze version is for marine use.

DIMENSIONI - DIMENSION

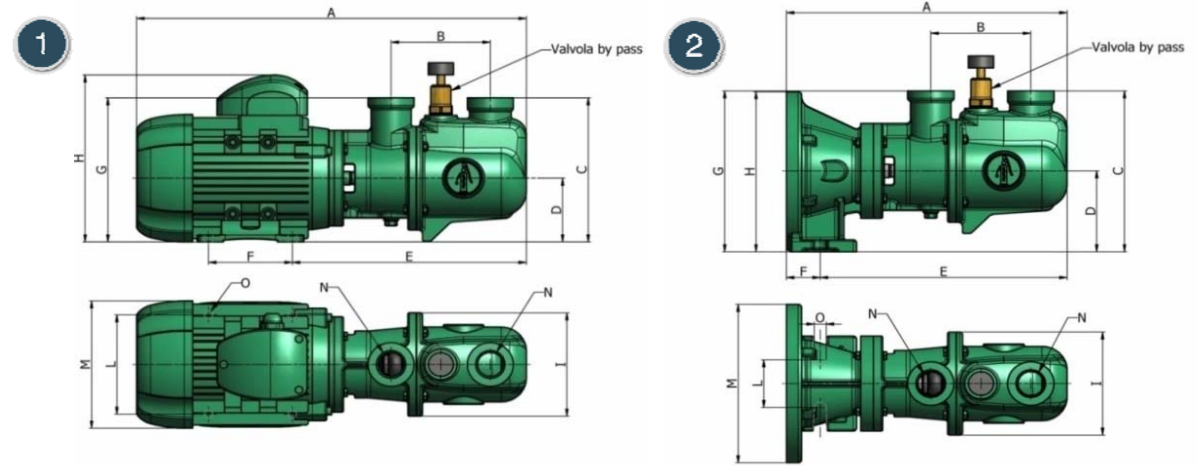

VERSIONE GHISA E BRONZO CAST IRON AND BRONZE VERSION

CORPO: Ghisa G25 UNI 5007 / Bronzo UNI EN 1982 CC491K
PUMP CASING: G25 UNI 5007 cast iron / Bronze UNI EN 1982 CC491K

ROTORE: AISI 304/316 e 304/316+cromo
ROTOR: St.Steel 304 / 316 / 304 HCP / 316 HCP

STATORE: NBR alimentare / EPDM / VITON

STATOR: NBR food grade / EPDM / VITON

GIUNTINO: AISI 316 / NBR / EPDM / VITON

COUPLING: St. steel. 316 / NBR / EPDM / VITON

BY-PASS: Lega di ottone

BY-PASS: OT 58

ALBERO MOTORE: AISI 304

MOTOR SHAFT: St.Steel 304

TENUTA MECCANICA DI SERIE: grafite / nitrile / altre a richiesta

STD MECHANICAL SEAL: graphite / nitrile / other on req.

MOTORIZZAZIONE: accoppiamento diretto con motore elettrico o supporto flangiato

MOTOR: electric motor direct coupling or with flanged support

VERSIONE INOX ST. STEEL VERSION

CORPO: AISI 304/316

PUMP CASING: St. Steel 304/316

ROTORE: AISI 304/316 e 304/316+cromo

ROTOR: St.Steel 304 / 316 / 304 HCP / 316 HCP

STATORE: NBR alimentare / EPDM / VITON

STATOR: NBR food grade / EPDM / VITON

GIUNTINO: AISI 316 / NBR alimentare / EPDM / VITON

COUPLING: St.Steel 316 NBR foodgrade / EPDM / VITON

BY-PASS: AISI 304 / 316

BY-PASS: St.Steel 304 / 316

ALBERO: AISI 304

DRIVE SHAFT: St.Steel 304

TENUTA DI SERIE: grafite / nitrile / altre a richiesta

STD MECHANICAL SEAL: graphite / nitrile / other on req.

MOTORIZZAZIONE: accoppiamento diretto con motore elettrico o supporto flangiato

MOTOR: electric motor direct coupling or with flanged support

PORTATE - PERFORMANCE

TYPE	l/min at 1bar	BAR MAX	RPM MAX
R24	9	7	1400
R28	5	7	1400
R40*	96	4	1400
R44	41	7	1400
R48	15	7	1400
R64	62	7	1400
R68	53	7	1400
R84	100	7	1400
R88	75	7	1400

(*) R40 disponibile solo inox / Available only st. steel

PERFORMANCE at 1 bar

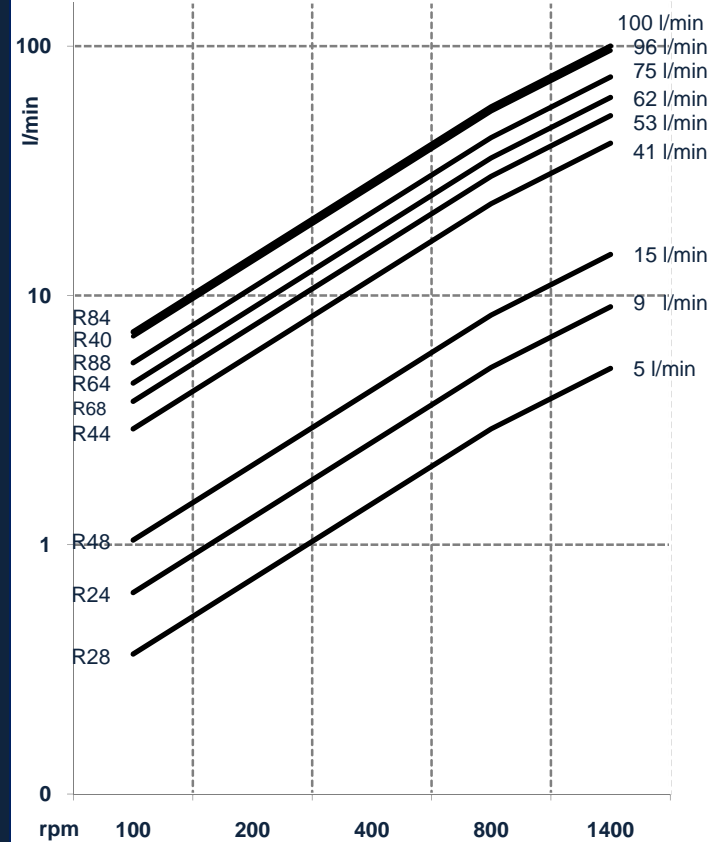

POTENZE MOTORI - POWER MOTORS

TYPE	4 poli / pole 1400 RPM	6 poli / pole 900 RPM	8 poli / pole 700 RPM
R24 R28	0,25 Kw	0,18 Kw	-
R44 R48	0,55 Kw	0,55 Kw	0,25 Kw
R64 R68	1,1 Kw	0,75 Kw	0,55 Kw
R84 R88	2,2 Kw	1,5 Kw	0,75 Kw

1 Dimensioni flottanti ghisa e bronzo* / Wobble cast iron and bronze* dimensions

TYPE	A	B	C	D	E	F	G	H	I	L	M	N	O	Kg
R24 R28	398	96	155	71	231,5	90	155	190	112	112	140	¾"	7	11,5
R44*R48*	466	118,5	181	80	279,5	100	181	210	130	125	163	1"	10	16,5
R64 R68	553	155	215	90	354	100	215	235	180	140	176	1" ¼	10	26
R84 R88	717	255	240	100	469	140	225	260	195	160	197	1" ½	12	43,5

2 Dimensioni flangiate flottanti ghisa e bronzo* / Flanged wobble cast iron and bronze* dimensions

TYPE	A	B	C	D	E	F	G	H	I	L	M	N	O	Kg
R24 F R28 F	-	-	-	-	-	-	-	-	-	-	-	-	-	-
R44 F* R48 F*	332,5	118,5	203	102	292,5	40	203	202	130	60	200	1"	14	15
R64 F R68 F	401	155	227	102	361	40	217	202	180	60	200	1" ¼	14	22

Valvola By-Pass a richiesta (come disegni) nei modelli R24-R28-R44-R48. By-Pass valve on request (as the drawings) in models R24-R28-R44-R48

(*) Disponibile anche in bronzo solo per i modelli R44-R48. Bronze available only for the models R44-R48

1 Dimensioni flottanti inox / Wobble stainless steel dimensions

TYPE	A	B	C	D	E	F	G	H	I	L	M	N	O	Kg
R24 R28	402	145	60	71	236	90	131	190	110	112	140	¾"	7	10
R44 R48	471	180	68	80	284,5	100	148	210	132	125	160	1"	10	15
R64 R68	566	240	90	90	366,5	100	180	235	180	140	176	1" ¼	10	22

2 Dimensioni flangiate flottanti inox / Flanged stainless steel dimensions

TYPE	A	B	C	D	E	F	G	H	I	L	M	N	O	Kg
R44 F R48 F	337,5	180	68	102	297,5	40	170	202	132	60	200	1"	14	13
R64 F R68 F	413,5	240	90	102	373,5	40	192	202	180	60	200	1" ¼	14	19

R40: Dimensioni disponibili solo a richiesta / Dimensions available only on request. R84-88 non disponibili inox / R84-88 not available st. steel