

## Centrifugal pumps - side mounted

Type **SQ**



### Usages:

The pumps are suitable to transfer liquids containing impurities measuring up to 2-3 mm. The hydraulic components, namely the impeller in nylon and the scroll in cast iron allow the pumps to be used with water, emulsions and oily substances in general with a maximum viscosity of 3° Engler (21 CST) and a maximum temperature of 70° c.

### They are usually used on:

**Machine tools (milling machines – lathes)**

**Surface treatment systems (de-oilers)**

They should be installed on the side of the tank to allow the liquid to enter straight into the suction mouth (see Figure).

In cases where the liquid is particularly dirty, the user is recommended to construct the tank in compartments to allow the dirt to deposit before it is stirred up by the pump.

**For other usages you are advised to consult our technical office**

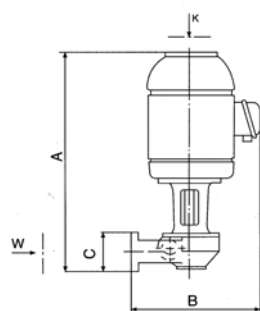

Vista secondo K

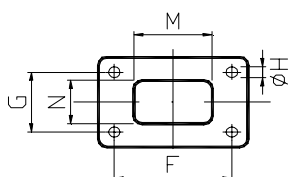
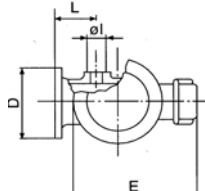

	M	N
SQ 56 - 63	50	30
SQ 71 - 80	80	40

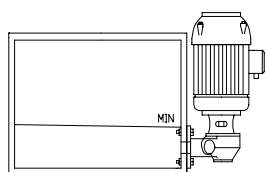
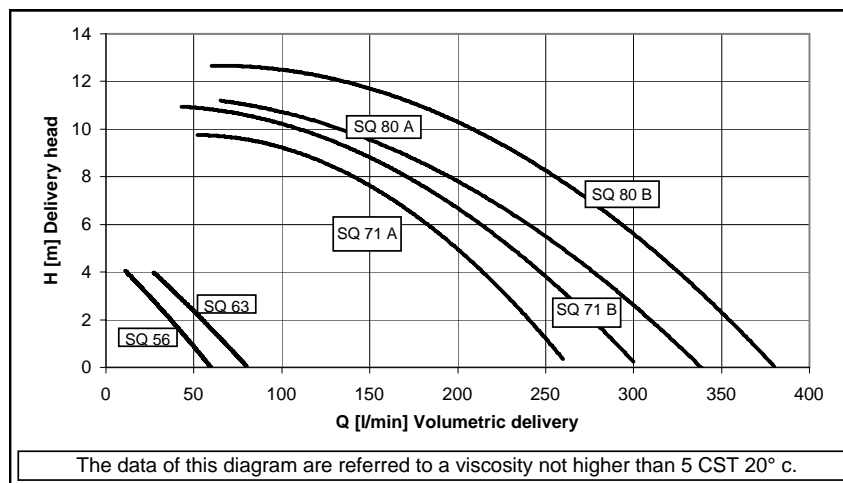

Table of dimensions and weights

TYPE	A mm	B mm	C mm	D mm	E mm	F mm	G mm	ØH mm	ØI mm	L mm	Kg.
SQ 56/S	265	170	60	95	140	75	45	7	3/8" 1/2"	51	3,87
SQ 63/S	300	180	60	95	158	75	45	7	3/8" 1/2"	51	4,95
SQ 71A	330	245	80	145	175	115	60	9	1"	62	14,50
SQ 71B	330	245	80	145	175	115	60	9	1"	62	15,20
SQ 80A	335	250	80	145	210	115	60	9	1 1/4"	62	16,30
SQ 80B	335	250	80	145	210	115	60	9	1 1/4"	62	17,30

Electrical features

TYPE	Kw Input	Hz. 50		Hz. 60			
		230/400	254-290/440-500	230/400	208-230/440-460	254-277/440-480	318-346/550-600
SQ 56/S	0,16	0,90/0,55	0,70/0,40	1,10/0,64	0,98/0,57	0,90/0,55	0,74/0,42
SQ 63/S	0,30	1,00/0,58	0,76/0,44	1,20/0,70	1,10/0,60	1,00/0,58	0,80/0,45
SQ 71A	0,53	2,40/1,40	1,94/1,12	3,00/1,68	2,60/1,50	2,40/1,40	2,00/1,17
SQ 71B	0,78	3,30/1,90	2,60/1,50	4,00/2,30	3,60/2,10	3,30/1,90	2,80/1,60
SQ 80A	1,15	3,30/1,90	2,60/1,50	4,00/2,30	3,60/2,10	3,30/1,90	2,80/1,60
SQ 80B	1,47	4,80/2,80	3,70/2,20	5,80/3,40	5,20/3,00	4,80/2,80	4,00/2,30



# Centrifugal pumps - side mounted

Type **SQ**

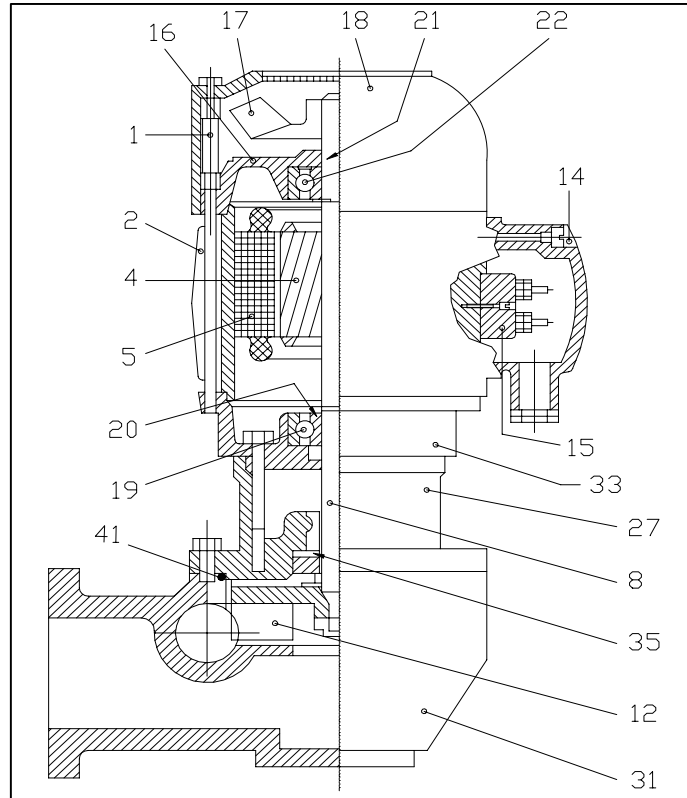

Type	SQ 56	SQ 63	SQ 71A-B	SQ 80A-B
<b>Components</b>	<b>Materials</b>	<b>Materials</b>	<b>Materials</b>	<b>Materials</b>
1 Rod	Steel	Steel	Steel	Steel
2 Frame	Aluminium	Aluminium	Aluminium	Aluminium
3 V-Ring	NBR ø 12	NBR ø 14	NBR ø 16	NBR ø 20
4 Rotor				
5 Stator				
8 Shaft	Steel C 40**	Steel C 40**	Steel C 40**	Steel C 40**
12 Impeller	Nylon*	Nylon*	Brass 58*	Brass 58*
14 Terminal box	Nylon	Nylon	Nylon	Nylon
15 Terminal block	mm. 40x25 6P	mm. 40x25 6P	mm. 40x25 6P	mm. 50X32 6P
16 Non-drive end shield	Aluminium	Aluminium	Aluminium	Aluminium
17 Fan	Nylon	Nylon	Nylon	Nylon
18 Fan cover	Nylon***	Nylon***	Nylon***	Nylon***
19 Bearing	6201 ZZ	6003 ZZ	6204 ZZ	6304 ZZ
21 Spring ring	ø 32	ø 35	ø 40	ø 47
22 Bearing	6201 ZZ	6202 ZZ	6203 ZZ	6204 ZZ
24 Flange	Aluminium	Aluminium	Aluminium	Aluminium
27 Cone	PBT	PBT	No	No
27 Coupling	No	No	Cast iron G20	Cast iron G20
31 House impeller	Cast iron G20	Cast iron G20	Cast iron G20	Cast iron G20
35 Mechanical seal	ø 12	ø 12	ø 19	ø 19
41 OR ring	NBR 56,87X1,78	NBR 56,87X1,78	No	No

**On request**

**	Aisi 420
***	Sheet