

## Immersion pumps

## Type SPV 12- 18



### Usages:

The pumps are suitable to transfer liquids containing impurities measuring up to 2-3 mm. The hydraulic components, namely the impeller, scroll and pump body in PBT allow the pumps to be used with water, emulsions and oily substances in general with a maximum viscosity of 3 Engler (21 CST). The temperature of the liquid must not exceed 70 °C.

### They are usually used on:-

**Machine tools** (milling machines – lathes - drills)  
**Glass processing machines** (TRI version)  
**Printing machines** (axis in AISI 420-316  
– PBT on depth of immersion 270 mm.)

### Air-conditioning systems

### Filtration systems

They should usually be installed on a tank, with a capacity in proportion to the flow rate, at about 3 – 4 cm. from the bottom. It is important to check that the maximum level of the liquid in the tank always remains 3– 4 cm. lower than the flange (see figure).

In cases where the liquid is particularly dirty, the user is recommended to construct the tank in compartments to allow the dirt to deposit before it is stirred up by the pump.

**For other usages you are advised to consult our technical office**

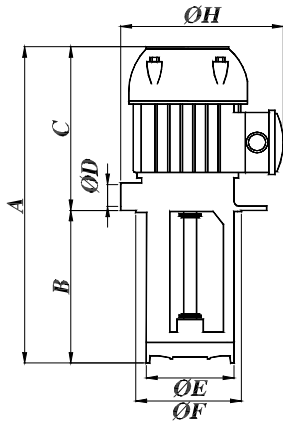

Table of dimensions and weights

TYPE	A mm	B mm	C mm	ØD	ØE mm	ØF mm	ØG mm	H mm	ØI mm	ØI mm	Kg.
SPV 12	255	90 T	165	3/4"	98	100	130	151	115	7 N. 4	2,80
	285	120 T									2,87
	335	170 T									2,95
	385	220 T									3,05
	435	270 T									3,15
	515	350									3,30
SPV 18	255	90 T	165	3/4"	98	100	130	151	115	7 N. 4	2,85
	285	120 T									2,92
	335	170 T									3,00
	385	220 T									3,10
	435	270 T									3,20
	515	350									3,35

On request: T = execution TRI

### Electrical features

TYPE	KW. Input	Hz. 50		Hz. 60			
		230/400	254-290/440-500	230/400	208-230/440-460	254-277/440-480	318-346/550-600
SPV 12	0,15	0,55/0,32	0,53/0,30	0,84/0,50	0,57/0,33	0,55/0,32	0,55/0,32
SPV 18	0,16	0,9/0,55	0,7/0,4	1,1/0,64	0,98/0,57	0,9/0,55	0,74/0,42

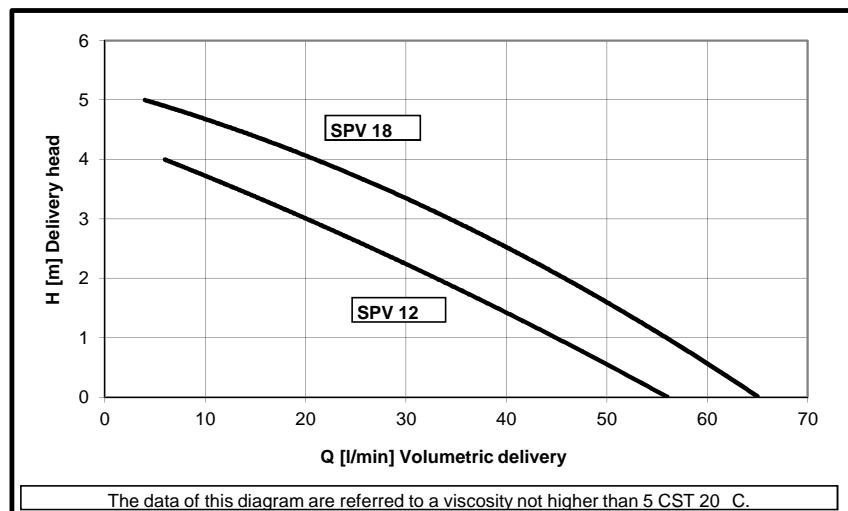
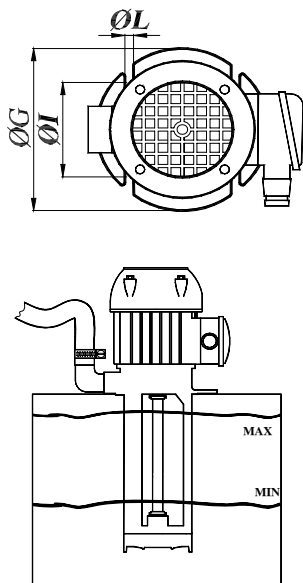

The data of this diagram are referred to a viscosity not higher than 5 CST 20 °C.

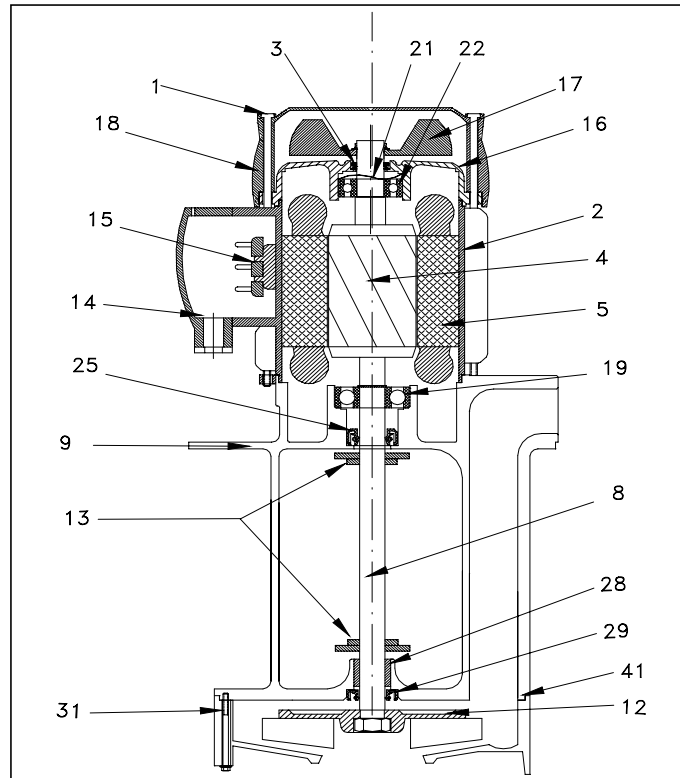

Type	SPV 12	
Components	Materials	
1	Rod	Steel
2	Frame	Aluminium
3	V-Ring Ø 12	NBR
4	Rotor	
5	Stator	
8	Shaft	Steel C 40**
9	Pump body	PBT
12	Impeller	PBT
13	Rubber washer	PBT
14	Terminal box	Nylon
15	Terminal block	mm. 40x25 6P
16	Non-drive end shield	Aluminium
17	Fan	Nylon
18	Fan cover	Nylon
19	Bearing	6201 2 RS
21	Spring ring	ø 32
22	Bearing	6201 ZZ
25	Sealing ring	NBR 12X22X5
28	Bronze bearing	14X12X10
29	Sealing ring	NBR 12X22X5
31	House impeller	PBT
41	OR 82,27X1,78	NBR

Type	SPV 18	
Components	Materials	
1	Rod	Steel
2	Frame	Aluminium
3	V-Ring Ø 12	NBR
4	Rotor	
5	Stator	
8	Shaft	Steel C 40**
9	Pump body	PBT
12	Impeller	PBT
13	Rubber washer	PBT
14	Terminal box	Nylon
15	Terminal block	mm. 40x25 6P
16	Non-drive end shield	Aluminium
17	Fan	Nylon
18	Fan cover	Nylon
19	Bearing	6201 2 RS
21	Spring ring	ø 32
22	Bearing	6201 ZZ
25	Sealing ring	NBR 12X22X5
28	Bronze bearing	14X12X10
29	Sealing ring	NBR 12X22X5
31	House impeller	PBT
41	OR 82,27X1,78	NBR

**Details 28-29 only on length mm. 220-270-350**

**On request**

\*\*

Aisi 420 - Aisi 316