

Immersion pumps

Type SP 25 - 33



Usages:

The pumps are suitable to transfer liquids containing impurities measuring up to 2-3 mm. The hydraulic components, namely the impeller and scroll in PBT and the cast iron pump body allow the pumps to be used with water, emulsions and oily substances in general with a maximum viscosity of 3° Engler (21 CST). The temperature of the liquid must not exceed 70° C.

They are usually used on:

- Machine tools (milling machines – lathes - drills)
- Surface treatment systems
- Filtration systems

They should usually be installed on a tank, with a capacity in proportion to the flow rate, at about 3 – 4 cm. from the bottom. It is important to check that the maximum level of the liquid in the tank always remains 3 – 4 cm. lower than the flange (see figure).

In cases where the liquid is particularly dirty, the user is recommended to construct the tank in compartments to allow the dirt to deposit before it is stirred up by the pump.

For other usages you are advised to consult our technical office

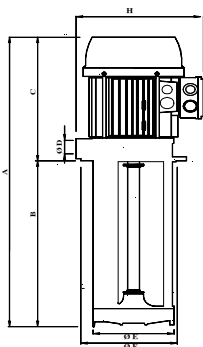
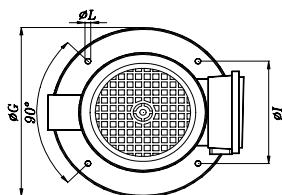

Table of dimensions and weights

TYPE	A mm	B mm	C mm	ØD	ØE mm	ØF mm	ØG mm	H mm	ØI mm	ØL mm	Kg.
SP 25	305	90 T	215	3/4"	98	100	130	170	115	7 N. 4	6,54
	335	120 T									6,84
	385	170 T									7,06
	435	220 T									7,24
	485	270 T									7,52
	565	350									8,08
SP 33	305	90 T	215	3/4"	98	100	130	170	115	7 N. 4	7,06
	335	120 T									7,34
	385	170 T									7,56
	435	220 T									7,74
	485	270 T									8,02
	565	350									8,58

On request: T = execution TRI



Electrical features

TYPE	KW. Input	Hz. 50		Hz. 60			
		230/400	254-290/440-500	230/400	208-230/440-460	254-277/440-480	318-346/550-600
SP 25	0,30	1,0/0,58	0,76/0,44	1,2/0,7	1,1/0,6	1,0/0,58	0,8/0,45
SP 33	0,40	1,6/0,9	1,2/0,7	1,9/1,1	1,73/1,0	1,6/0,9	1,2/0,7

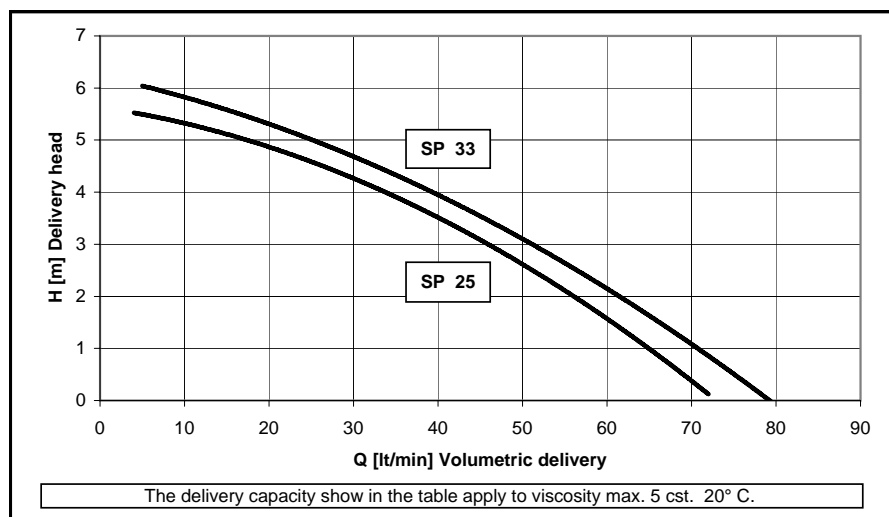
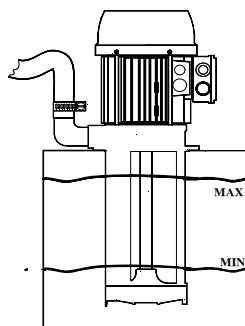

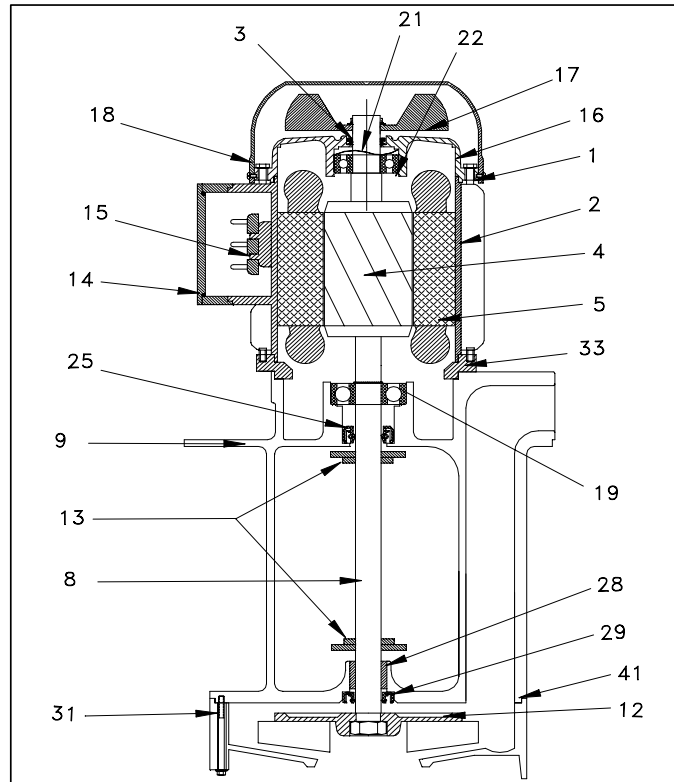

Type	SP 25	
Components	Materials	
1	Rod	Steel
2	Frame	Aluminium
3	V-Ring ø 16	NBR
4	Rotor	
5	Stator	
8	Shaft	Steel C 40**
9	Pump body	Cast iron G 20
12	Impeller	PBT*
13	Rubber washer	PBT
14	Terminal box	Nylon
15	Terminal block	mm. 40x25 6P
16	Non-drive end shield	Aluminium
17	Fan	Nylon
18	Fan cover	Nylon***
19	Bearing	6003 ZZ
21	Spring ring	ø 35
22	Bearing	6202 ZZ
25	Sealing ring	NBR 17X25X4
28	Bronze bearing	19X17X15
29	Sealing ring	NBR 17X25X4
31	House impeller	PBT*
33	Flange	Aluminium
41	OR ring	NBR 82,27X1,78

Type	SP 33	
Components	Materials	
1	Rod	Steel
2	Frame	Aluminium
3	V-Ring ø 16	NBR
4	Rotor	
5	Stator	
8	Shaft	Steel C 40**
9	Pump body	Cast iron G 20
12	Impeller	PBT*
13	Rubber washer	PBT
14	Terminal box	Nylon
15	Terminal block	mm. 40x25 6P
16	Non-drive end shield	Aluminium
17	Fan	Nylon
18	Fan cover	Nylon***
19	Bearing	6003 ZZ
21	Spring ring	ø 35
22	Bearing	6202 ZZ
25	Sealing ring	NBR 17X25X4
28	Bronze bearing	19X17X15
29	Sealing ring	NBR 17X25X4
31	House impeller	PBT*
33	Flange	Aluminium
41	OR ring	NBR 82,27X1,78

Details 28 - 29 only non body pump length mm. 350

Details 28 - 29 only non body pump length mm. 350

On request

*	Cast iron G 20
**	Aisi 420
***	Sheet

On request

*	Cast iron G 20
**	Aisi 420
***	Sheet