

Immersion pumps

Type EPC 63 - 71



Usages:

These pumps are suitable for transferring clean liquids containing impurities measuring up to 30 micron.

The hydraulic components, namely the brass impeller, scroll and cast iron pump body, allow the pumps to be used with emulsions and oily substances, glycols and liquids in general, as long as they are not oxidative for the construction materials.

Viscosity must not exceed 3° Engler (21 CST).

The temperature of the liquid must not exceed 90° C.

They are usually used on:

- Boring centres
- Cooling exchanges

They should usually be installed on a tank, with a capacity in proportion to the flow rate, at about 3-4 cm. from the bottom. It is important to check that the maximum level of the liquid in the tank always remains 3 – 4 cm. lower than the flange (see figure).

For other usages you are advised to consult our technical office.

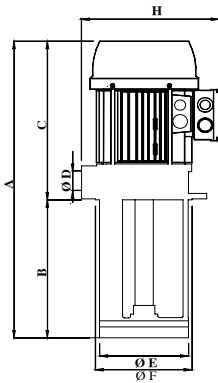
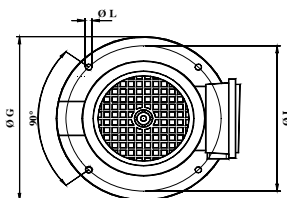

Table of dimensions and weights

TYPE	A mm	B mm	C mm	ØD	ØE mm	ØF mm	ØG mm	H mm	ØI mm	ØL mm	Kg.
EPC 63 C	310	100	210	3/4"	98	100	130	185	115	7 N. 4	8,900
	340	130									9,210
	390	180									9,410
	440	230									9,610
	490	280									9,780
	570	360									10,340
EPC 71 B	360	100	260	3/4"	98	100	130	193	115	7 N. 4	11,580
	390	130									11,890
	440	180									12,090
	490	230									12,290
	540	280									12,460
	620	360									13,020



Electrical features

TYPE	KW. Input	Hz. 50		Hz. 60			
		230/400	254-290/440-500	230/400	208-230/440-460	254-277/440-480	318-346/550-600
EPC 63C	0,54	1,9/1,1	1,52/0,88	2,3/1,32	2,2/1,3	1,9/1,1	1,6/0,92
EPC 71B	1,10	3,3/1,9	2,6/1,5	4,00/2,3	3,6/2,1	3,3/1,9	2,8/1,6

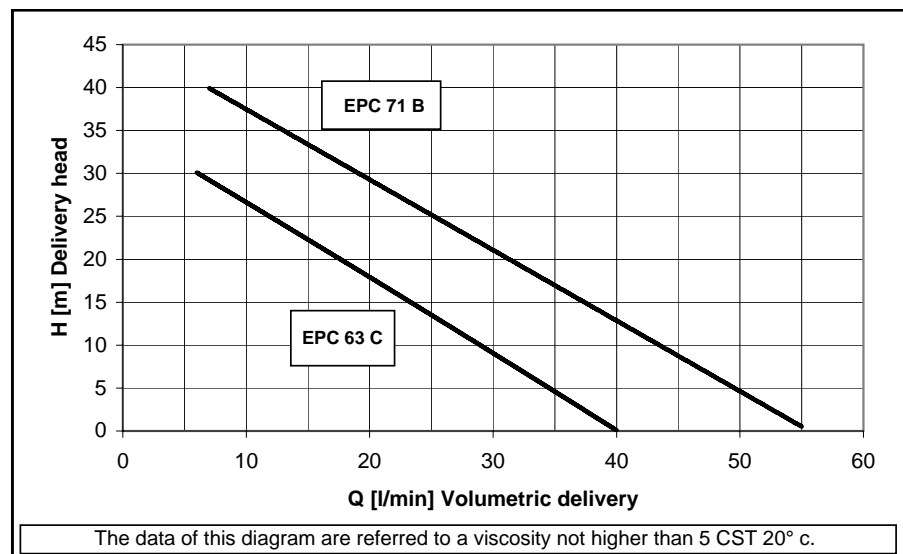
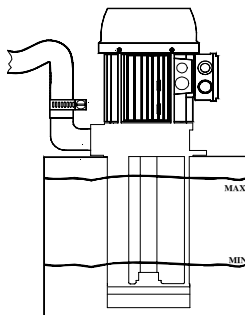

Immersion pumps

Type EPC 63 - 71

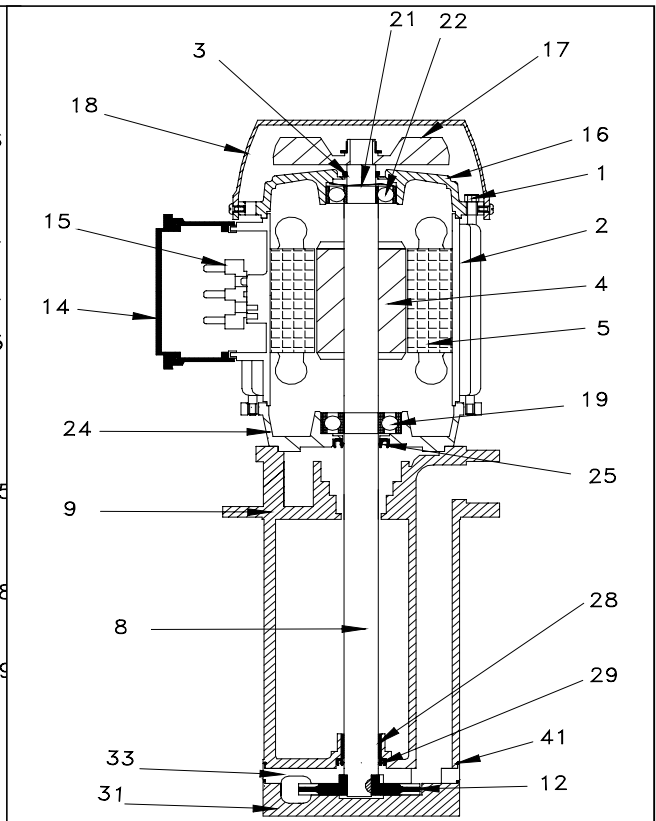
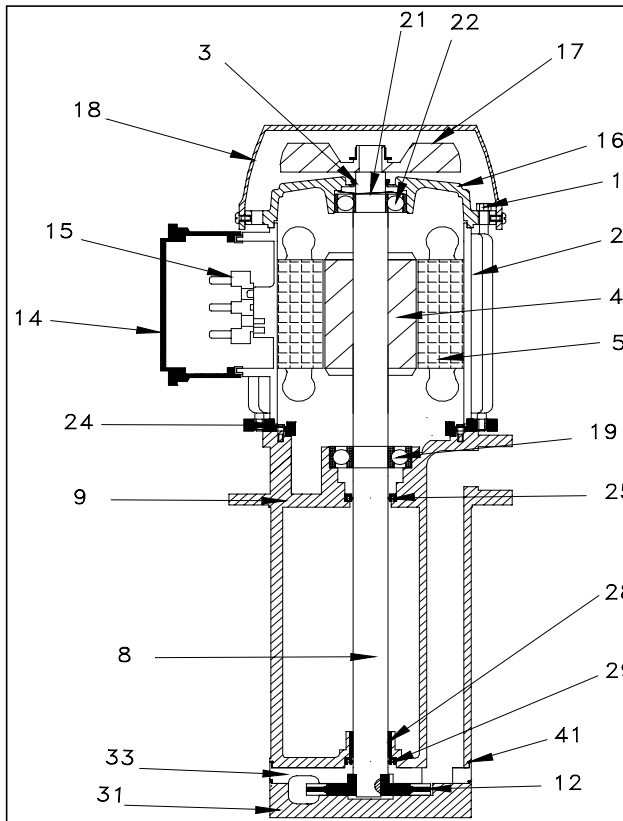

Type EPC 63C

Type EPC 71B

Components	Materials
1 Rod	Steel
2 Frame	Aluminium
3 V ring	NBR ø 16
4 Rotor	
5 Stator	
8 Shaft	Steel C 40**
9 Pump body	Cast iron G 20
12 Impeller	Brass 58
14 Terminal box	Nylon
15 Terminal block	mm. 40x25 6P
16 Non-drive end shield	Aluminium
17 Fan	Nylon
18 Fan cover	Nylon***
19 Bearing	6203 ZZ
21 Spring ring	ø 35
22 Bearing	6202 ZZ
24 Spacer	Aluminium
25 Sealing ring	NBR 17x25x4
28 Bronze bearing	19X17X15
29 Sealing ring	NBR 17x25x4
31 House impeller	Cast iron G 20
33 Adapter flange	Cast iron G 20
41 O-Ring	NBR 82,27x1,78

Components	Materials
1 Rod	Steel
2 Frame	Aluminium
3 V ring	NBR ø 16
4 Rotor	
5 Stator	
8 Shaft	Steel C 40**
9 Pump body	Cast iron G 20
12 Impeller	Brass 58
14 Terminal box	Nylon
15 Terminal block	mm. 40x25 6P
16 Non-drive end shield	Aluminium
17 Fan	Nylon
18 Fan cover	Nylon***
19 Bearing	6304 ZZ
21 Spring ring	ø 40
22 Bearing	6203 ZZ
24 Drive end shield	Aluminium
25 Sealing ring	NBR 20X32X7
28 Bronze bearing	19X17X15
29 Sealing ring	NBR 17x25x4
31 House impeller	Cast iron G 20
33 Adapter flange	Cast iron G 20
41 O-Ring	NBR 82,27x1,78

On request

**

Aisi 420

Sheet