

Submersible pumps for wastewater without sewage

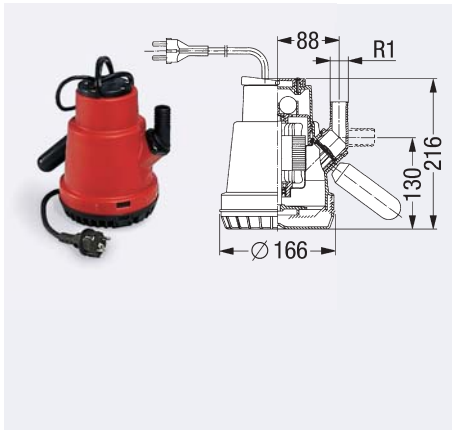

Illustration and dimensioned drawing



Article description

Submersible pump **KTP 300**

with/without float switch

With backwater flap, pivotable connection.

Intake power: 340 W.
Voltage: 230 V ~ 50 Hz.
max. pumping height: 6 m.
max. pumping capacity: 8 m³/h.
Max. submersible depth: 10 m.
max. particle size: 10 mm.
Pressure connection: 1 inch side / vertical
Cable length: 10 m.

Removable intake basket - reduction in the water level to 8 mm possible.



CE EN 12050-1

Pressure connection

Article

Model without float switch

1 inch 28740

Model with float switch

1 inch 28840

Performance diagram **KTP 300**

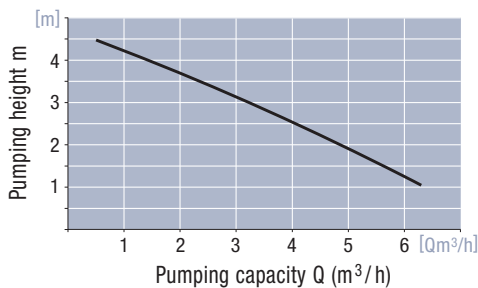

Current type	Voltage	Current	Motor rating P ₁ / P ₂	RPM	Motor protection	Plug
Alternating current	230 V	1.9 A	340 W / 220 W	2800 min ⁻¹	integrated	Schuko

Jansen
POMPEN- & WATERTECHNIEK

Hoogeindsestraat 5
NL - 5447 PD Rijkevoort
Nederland
T : +31 (0) 485 - 371318
F : +31 (0) 485 - 371918
info@pompentechniek.nl
www.pompentechniek.nl