



Hoogeindsestraat 5
NL - 5447 PD Rijkevoort
Nederland
T : +31 (0) 485 - 371318
F : +31 (0) 485 - 371918

Submersible motor pumps DN 40 to DN 700

Cast iron and various materials for industrial effluents

**50 Hz
standard range**

**Stationary installation
Transportable installation
Dry-installed**



Other versions on request

Automation products available:

- PumpExpert
- Hyamaster
- hyatronic
- LevelControl Basic 2

Applications

Amarex submersible motor pumps are used for pumping all types of sewage and effluent in water treatment and industry, especially untreated sewage with long fibrous and solid substances, liquids containing air and gas as well as raw, activated and digested sludge.

Operating data

Capacity	Q	up to 10 000 m ³ /h, 2 778 l/s
Head	H	up to 100 m
Motor power	P ₂	from 0.8 kW to 850 kW
Temperature of pumped liquid	t	up to 60 °C
Enclosure type	IP 68 to IEC 60034-5 additional flameproof versions ATEX II 2G T3 or T4	

Drive

Three-phase asynchronous motor
400 V (variants: 230 V, 380 V, 415 V, 500 V, 690 V)

Material

Standard version of cast iron
Material variants of wear-resistant chilled iron and corrosion-resistant duplex stainless steel

Shaft sealing

2 mechanical seals being independent of the direction of rotation, lubricated with non-toxic oil

Bearings

grease lubricated ball bearings

Designation

Example

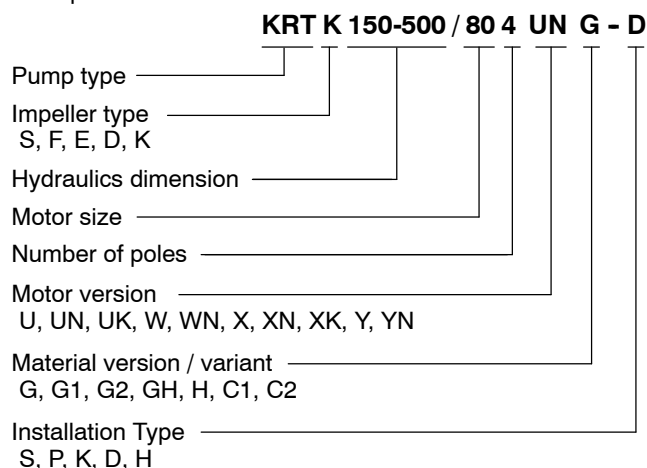

New:

Motor versions with energy-saving motors IE2 - High Efficiency or IE3 - Premium Efficiency (classification to EN 60034-30 based on EC Directive 640/2009 for standardised motors)

Contents

	Page
Product advantages _____	3
Impeller Types _____	4
Guide to material and hydraulics selection for individual pumped liquids _____	5
Selection Diagrams 50 Hz _____	6-9
Guarantee, Tests / Inspections and Quality Assurance _____	9
Technical Data _____	10-12
Installation Types _____	13
Materials _____	14
TECHNICAL DATA - STANDARD PROGRAMME / (standard variants) _____	15-16
Typical sectional drawing _____	17-18
Shaft Seal _____	19

Product advantages

Example: Amarex KRT K 100-250/7 4WG

Absolutely water-tight

Even in the event of power cable damage, no fluid can penetrate into the motor.

Reliability

Motors specially developed for submersible motor pumps offer maximum operating safety.

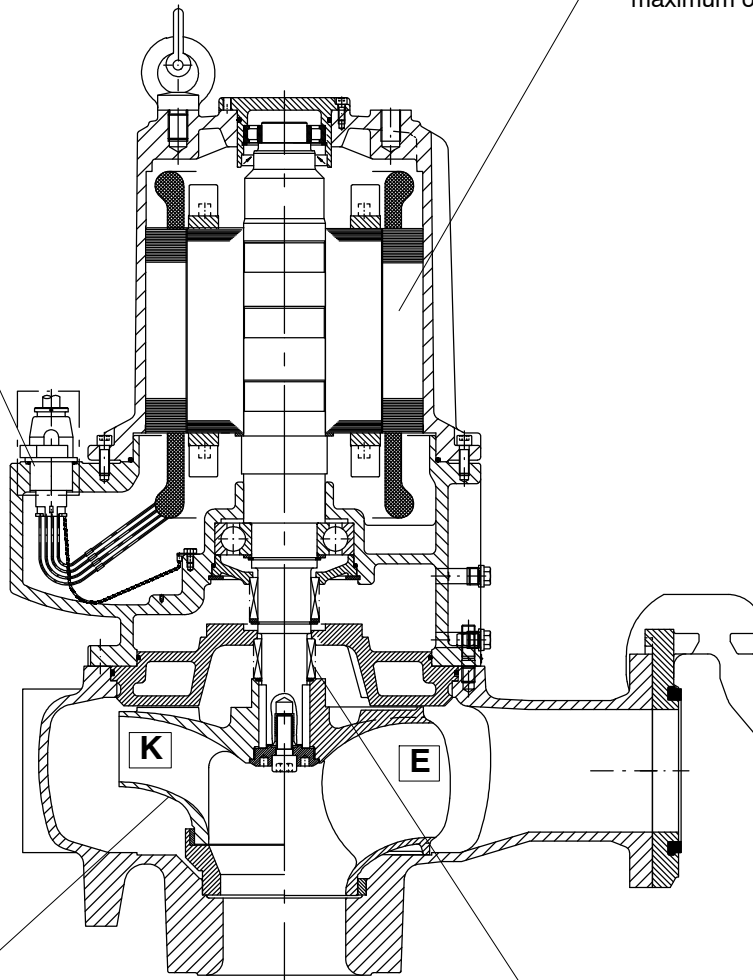

Variable hydraulic system

The right impeller with optimum efficiency for every fluid. High operating reliability due to wide free passages.





Long service life

2 bi-rotational mechanical seals

Impeller Types

KRT K 150-315 / 12 6 U G - S

S, F, E, D, K

 <p>(S)</p>	<p>Impeller with cutting device</p> <hr/> <p>S-Impeller for handling domestic sewage with coarse and / or long fibrous matter</p> <ul style="list-style-type: none"> ● domestic sewage ● dirty water ● faeces 	 <p>(D)</p>	<p>Open single vane impeller</p> <hr/> <p>D-Impeller for sewage containing solid substances, long fibres and coarse dirt.</p> <ul style="list-style-type: none"> ● raw sewage ● mixed water ● raw and digested sludge ● activated sludge ● circulated and heated sludge
 <p>(F)</p>	<p>Vortex impeller</p> <hr/> <p>F-Impeller or liquids containing long fibres, solid substances, coarse dirt as well as gas or air.</p> <ul style="list-style-type: none"> ● raw sewage ● activated sludge ● circulated and heated sludge ● raw and digested sludge ● mixed water 	 <p>(K)</p>	<p>Closed non-clogging 2 or 3 canal impeller</p> <hr/> <p>K-Impeller for contaminated liquids containing sludges and solids which are non-gaseous and not containing fibres liable to twist or bunch.</p> <ul style="list-style-type: none"> ● screened sewage ● mechanically treated sewage ● industrial waste water ● effluent from waste disposal sites ● storm water ● activated sludge ● industrial effluent
 <p>(E)</p>	<p>Single vane impeller</p> <hr/> <p>E-Impeller for sewage containing long fibres and solid substances.</p> <ul style="list-style-type: none"> ● raw sewage ● mixed water ● raw and digested sludge ● activated sludge ● circulated and heated sludge 	<p>! Hydraulic systems with S-, D-, F- and E-impellers are available only as shown in the documented QH parameters. !</p> <p>■ K-impellers can be adjusted to the required duty point. ■</p>	

Guide to material and hydraulics selection for individual pumped liquids

The table below is intended as a guide for selecting pump materials and hydraulics and is based on many years of KSB experience. The data given in the table is intended as a recommendation / guide only. For more detailed information, please consult your nearest KSB sales office or ask for expert advice from the KSB advisory departments. Take advantage of the extensive KSB laboratory know-how when selecting pump materials.

Recommended material	Pumped liquid	Suggested impeller type	Comments and recommendations
Cast Iron	Dirty water	K, D, E, F	free passage >solids in pumped liquid, possibly pre-screened
	River water		
	Storm water		
	Waste water		
	- untreated municipal sewage	F, S, D, E, K	ATV recommendation: free passage of 100 mm, min 76 mm (3")
	- containing gas and air	F	up to 8 % , consult KSB when pumping highly gaseous liquids.
	Sludges		
	- raw sludge	F, D, E	can be pumped with a solids content : 13 % (D), 8 % (F), 6 % (E), 5 % (K)
	- digested sludge	F, D, E	
	- activated sludge	D, K	
	Industrial effluent contaminated with ...		
	- paint suspension	K	solvent-free; refer to operator instruction
	- varnish suspension	F, E	solvent-free; consult KSB for silicone-free version
	- fibrous substances	F, S, D	
	- filings / chippings	K, F	G2 or GH variant, special mechanical seal
	- abrasive substances	K, F	Solids content <5 g/l
	Industrial effluent, slightly acid	K, F	ph-value <5.5 C1 variant and FPM (Viton) O-rings
	Waste water, chemically neutral in respect of corrosion		
	- ammonia water	K	
	- ammonia hydroxide 5 % NH ₄ OH	K	
	- urea 25 % (NH ₂) ₂ -CO	K	
	- potassium hydroxide 10 % KOH	K	
	- calcium hydroxide 5 % Ca(OH) ₂	K	
	- sodium hydroxide 5 % NaOH	K	
	- sodium carbonate 30 % Na ₂ CO ₃	K	
	Waste water, chemically neutral in respect of corrosion, contaminated with ...		
	- aliphatic hydrocarbons, e.g. oils, petrol, butane, methane	K	FPM (Viton) O-rings, for high concentrations consult KSB
- aromatic hydrocarbons, e.g. benzene, styrene	K		
- chlorinated hydrocarbons, e.g. trichloroethylene, ethylene chloride, chloroform, methylene chloride	K		
Chilled iron	Highly abrasive industrial waste water (chemically neutral)		
	- sinter water	K	A sinter content of <5 g/l requires GH design A sinter content of >5 g/l requires H design
	- lime-milk with quartz and pigment suspension	K	up to 15% lime-milk requires GH design >15% lime-milk requires H design
	- wash water containing solids	K, F	material variant depends on liquid analysis
	- waste water containing dust / ash	K	
	Water-sand mixture	K, F	up to 5 g/l solids content requires GH variant - above 5 g/l: H variant
Duplex-steel	Sea water	K, F	C2-variant
	Brackish water	K, F	C1 or G1 (with 250 µm 2-comp. epoxy resin), - depending on salt content
	Corrosive industrial effluent	K, F	C1 or C2, depending on analysis of pumped media

Selection Diagrams 50 Hz

S-Impeller

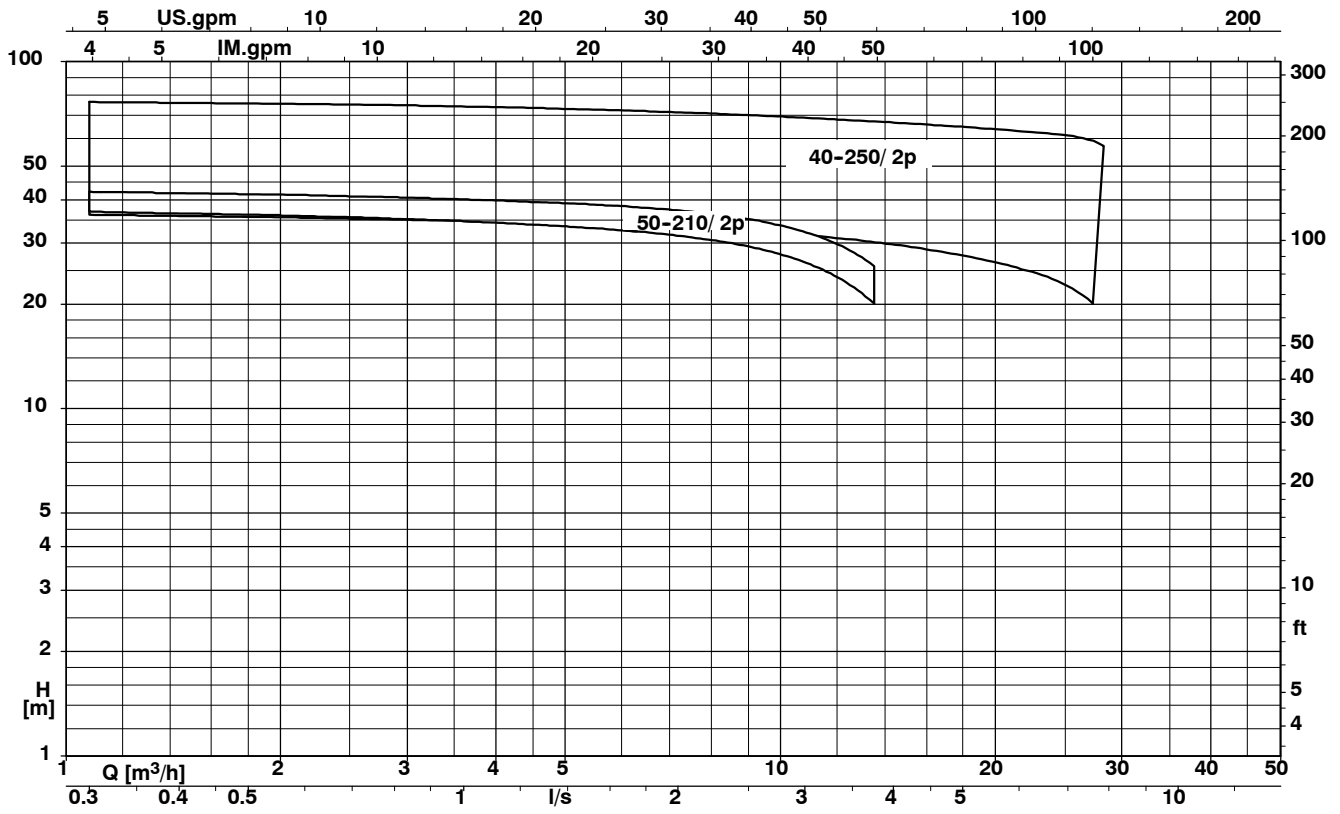

F-Impeller

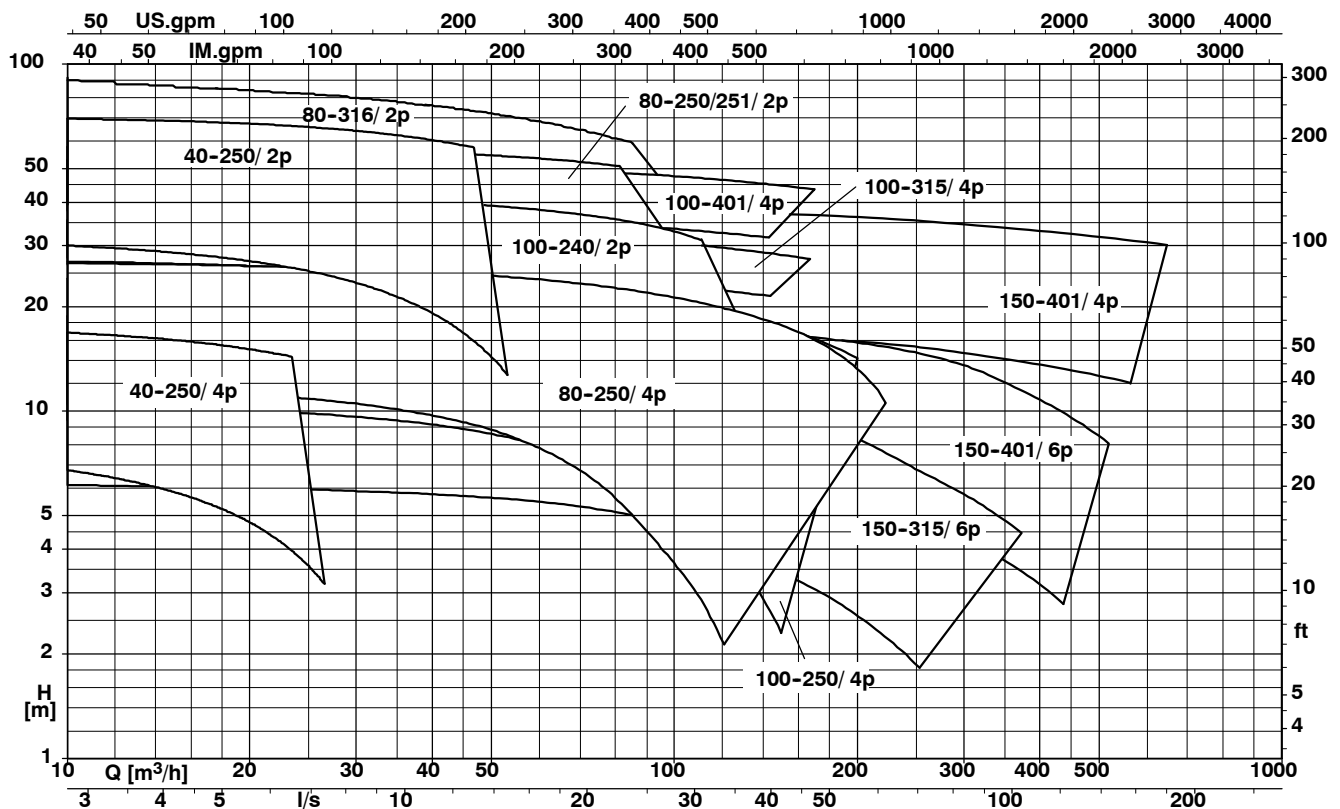

E-Impeller

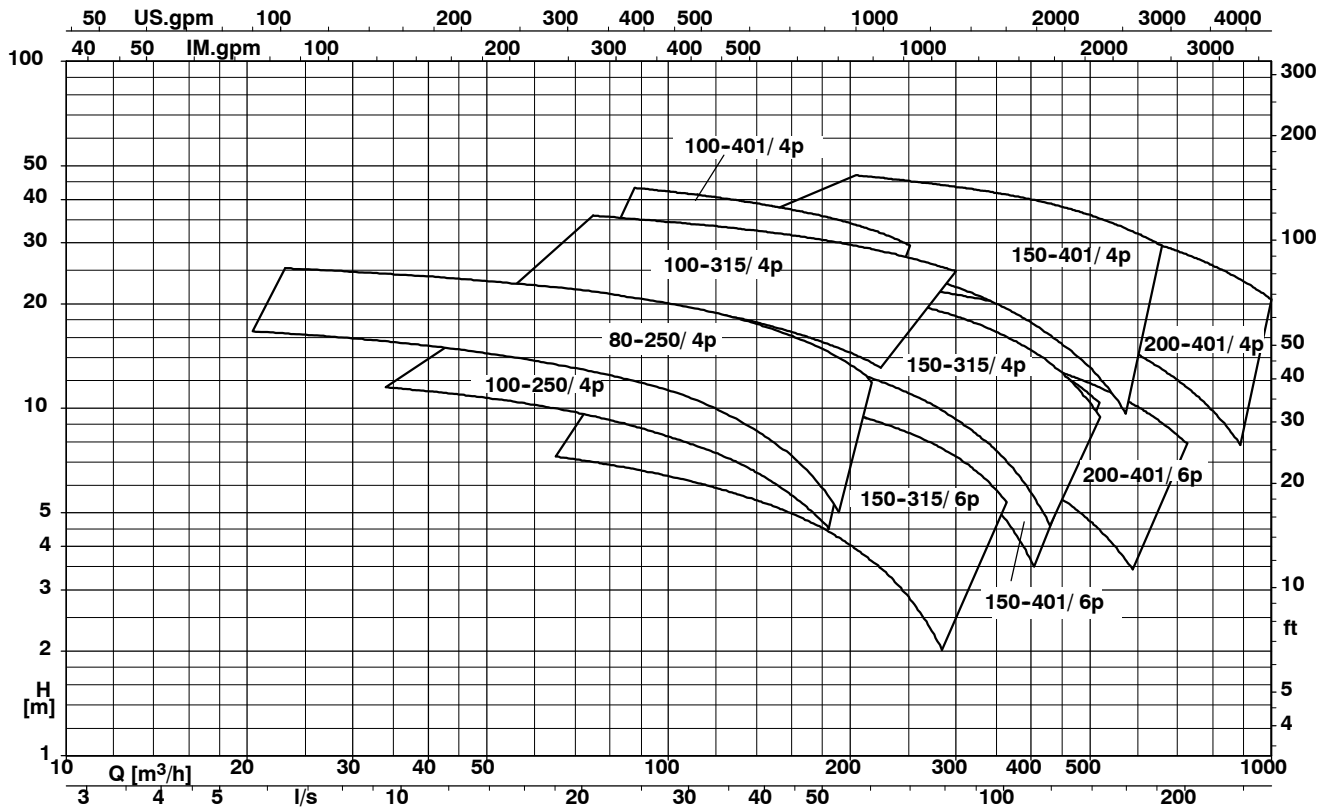

D-Impeller

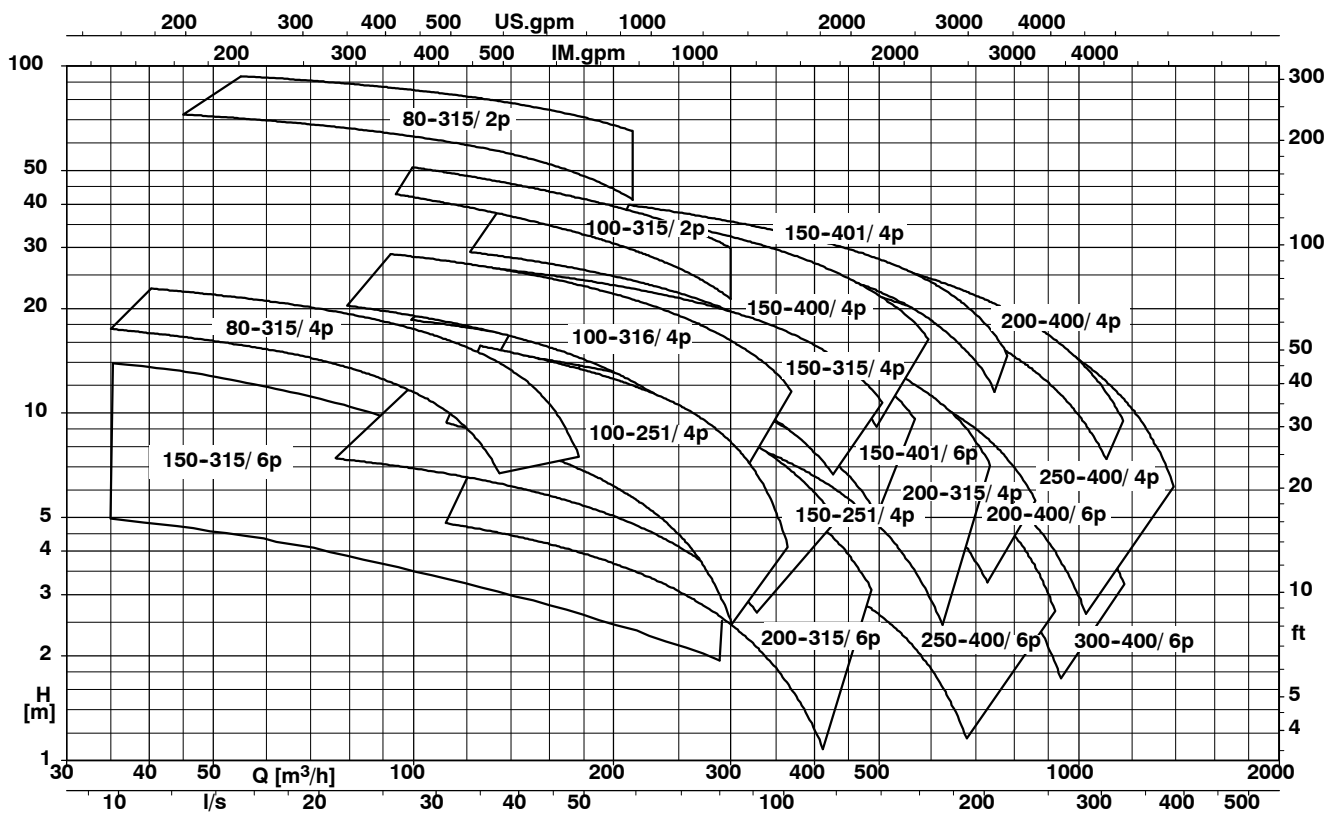

K-Impeller

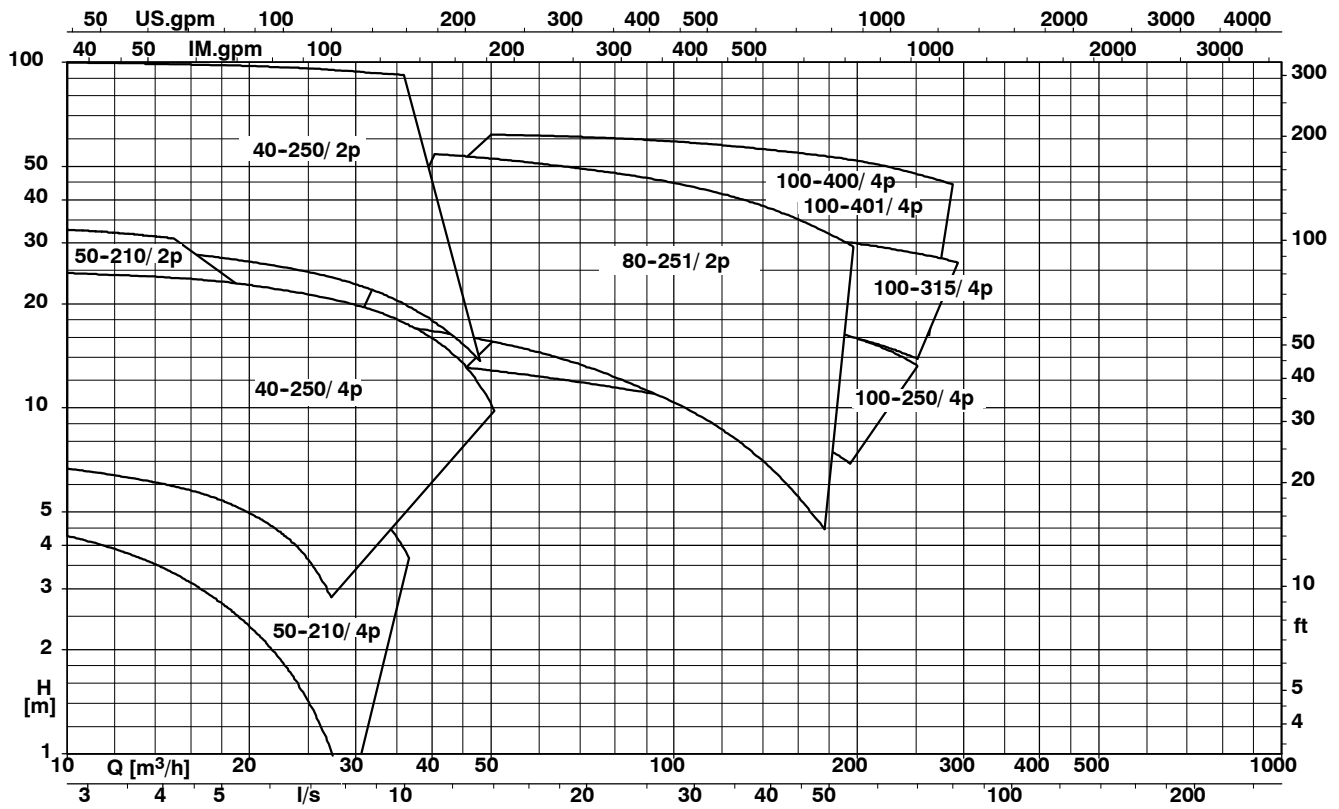

K-Impeller

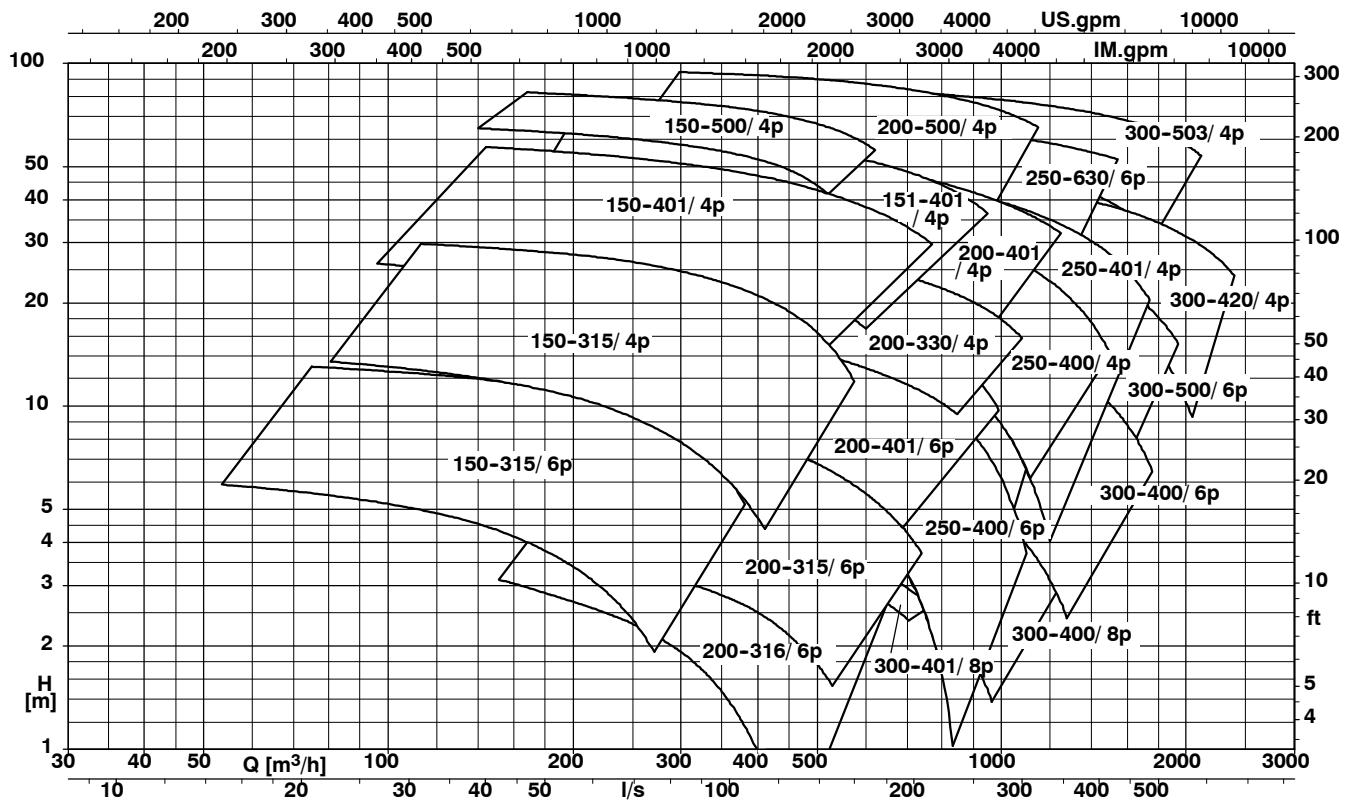

K-Impeller

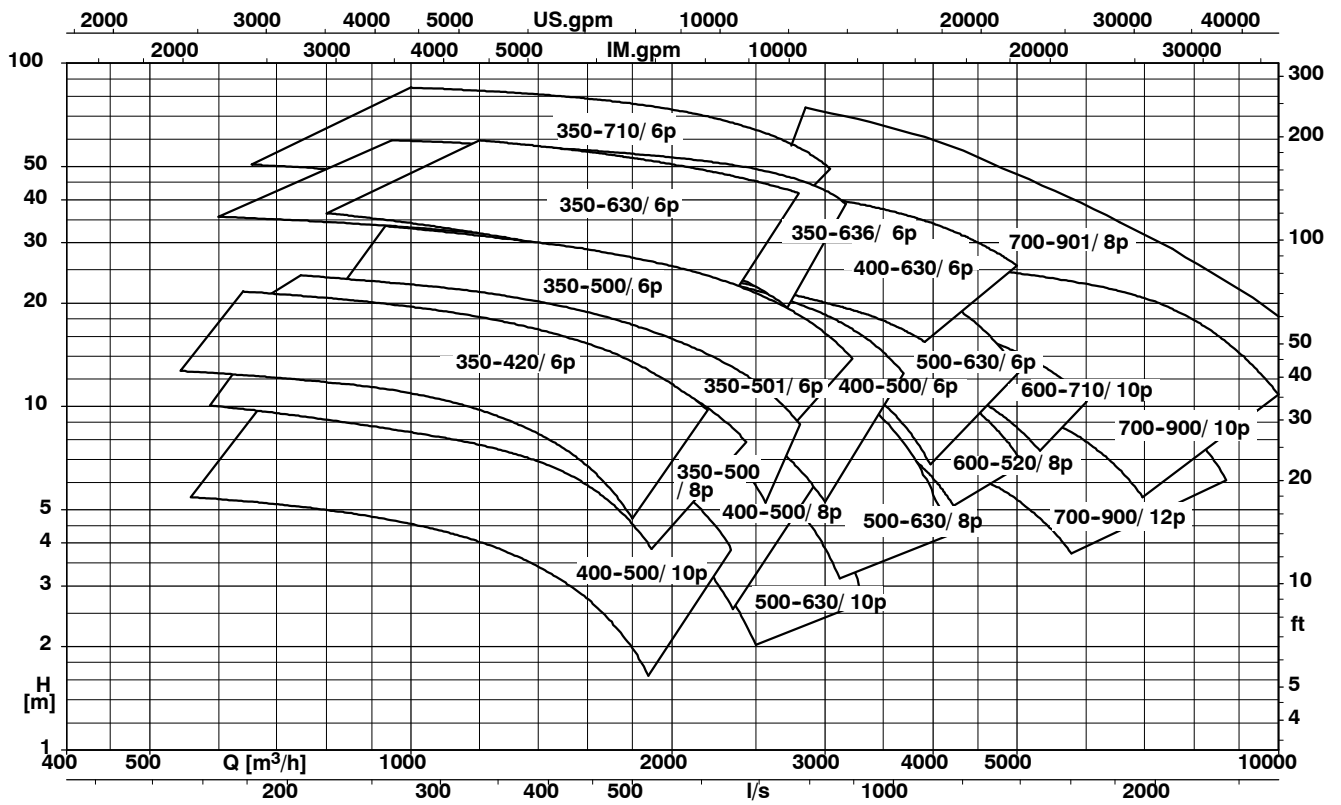

Guarantee, Tests / Inspections and Quality Assurance

Each pump is subjected to a functional test to KSB standard ZN 56 525. Pump performance is guaranteed to ISO 9906/A. Acceptance inspections conforming to ISO / DIN or another comparable standard are possible at a surcharge. The quality is assured under a tested and to DIN EN ISO 9001 certified quality assurance system.

Technical Data
Cast iron (G, G1, G2, GH)

Pump sizes	Material variants	Impeller				Dry installation (Installation Type "D", "H")		Wet-well installation (Installation Type "S", "P", "K")		Moment of inertia $J_{2, 3}$		
		Impeller channels	Free passage	D _{2max}	D _{2min}	max. operating pressure ¹⁾	max. test pressure	max. operating pressure ¹⁾	max. test pressure			
		qty.	[mm]	[mm]	[mm]	[bar]	[bar]	[bar]	[bar]			
S 40-250	G	4	7	225	175	-	-	10.1	13.1	0.030		
F 40-250	G, G1, G2, GH	-	25	210	150	-	-	10.0	13.0	0.030		
F 80-250			76	265	150	6	9	6.5	8.5	0.140		
F 80-251	G	-	50	230	145	-	-	6.7	8.7	0.057		
F 80-316			65	265	200	-	-	8.1	10.5	0.075		
F 100-240	G, G1, G2, GH	-	100	190	170	-	-	3.7	4.8	0.130		
F 100-250			100	265	200	6	9	3.6	4.7	0.056		
F 100-315			100	310	270	-	-	4.3	5.6	0.056		
F 100-401			100	390	325	10	15	9.5	12.4	0.248		
F 150-315			120	290	250	6	9	3.5	4.6	0.144		
F 150-401			135	390	270	10	15	9.1	11.8	0.248		
E 80-250	G	1	76	270	225	6	9	6.5	8.5	0.17		
E 100-250			90	245	202	6	9	3.6	4.7	0.16		
E 100-315			100	330	262	-	-	4.3	5.6	0.26		
E 100-401			80	412	389	-	-	9.5	12.4	0.60		
E 150-315			110	320	254	6	9	3.5	4.6	0.31		
E 150-401			115	407	348	10	15	9.1	11.8	0.68		
E 200-401			120	400	319	10	15	7.2	9.4	0.86		
D 80-315			G, G1	1	65	265	234	10	15	10.6	13.8	0.124
D 100-251	76	265			234	6	9	3.5	4.6	0.115		
D 100-315	75	222			196	-	-	6.8	8.8	0.065		
D 100-316	85	306			270	-	-	3.6	4.7	0.233		
D 150-251	100	254			225	6	9	1.9	2.5	0.115		
D 150-315	100	317			280	6	9	3.3	4.3	0.289		
D 150-400	100	363			326	-	-	5.2	6.8	0.573		
D 150-401	110	384			370	-	-	5.4	7.0	0.999		
D 200-315	100	315			280	6	9	2.7	3.5	0.261		
D 200-400	100	375			365	-	-	3.4	4.4	0.825		
D 250-400	120	375			320	-	-	3.6	4.7	0.653		
D 300-400	150	408			375	-	-	1.7	2.2	0.925		
K 40-250	G, G1, GH	3			15	260	150	-	-	10.0	13.0	0.047
K 80-251	G	3			33	220	140	-	-	6.7	8.7	0.150
K 100-250	G, G1, GH	2	71	256	210	6	9	3.6	4.7	0.070		
K 100-315			80	312	254	-	-	4.3	5.6	0.150		
K 100-400	G	2	76	408	350	-	-	9.5	12.4	1.100		
K 100-401	G, G1, GH	2	50	404	310	10	15	9.5	12.4	0.504		
K 150-315			76	310	235	6	9	3.5	4.6	0.180		
K 150-401			76	404	330	10	15	9.1	11.8	0.916		
K 151-401			3	80	404	320	10	15	8.8	11.4	0.520	
K 150-500	G, G1	3	60	460	420	10	15	9.0	11.7	0.710		
K 200-315	G, G1, GH	3	70	295	245	6	9	1.9	2.5	0.22		
K 200-316		2	100	305	265	6	9	1.7	2.2	0.22		
K 200-330		3	70	326	287	10	15	5.5	7.2	0.35		
K 200-401		80	404	330	10	15	7.2	9.4	0.52			
K 200-500	G, G1	3	76	504	400	10	15	10.0	13.0	0.83		
K 200-501		2	105	502	450	10	15	6.5	8.5	1.68		
K 200-631		105	622	540	10	15	10.0	13.0	4.41			
K 250-400	G, G1, GH	3	85	370	300	10	15	7.0	9.1	0.50		
K 250-401		2	105	400	310	10	15	6.0	7.8	0.55		
K 250-630	G, G1	3	90	630	500	10	15	10.5	13.7	2.76		
K 300-400	G, G1, GH	3	100	408	332	10	15	3.6	4.7	0.75		
K 300-401		2	135	408	367	10	15	2.3	3.0	0.75		

¹⁾ Allow. operating pressure = inlet pressure + pressure at Q = 0

²⁾ Values for biggest impeller diameter

³⁾ Impeller with water fill

Cast iron (G, G1, G2, GH)

Pump sizes	Material variants	Impeller				Dry installation (Installation Type "D", "H")		Wet-well installation (Installation Type "S", "P", "K")		Moment of inertia J _{2), 3)} [kgm ²]
		Impeller channels	Free passage	D _{2max}	D _{2min}	max. operating pressure ¹⁾	max. test pressure	max. operating pressure ¹⁾	max. test pressure	
		qty.	[mm]	[mm]	[mm]	[bar]	[bar]	[bar]	[bar]	
K 300-420	G, G1	3	100	408	370	6	9	5.6	7.3	0.95
K 300-500			90	504	430	10	15	4.5	5.9	1.48
K 300-503		5	50	480	405	10	15	9.2	12.0	2.50
K 350-420		3	100	450	387	6	9	3.6	4.7	1.22
K 350-500			110	508	426	6	9	5.8	7.5	3.12
K 350-501		2	170	509	495	6	9	2.8	3.6	3.00
K 350-630		3	135	630	500	10	15	7.5	9.8	5.22
K 350-636		5	75	630	510	10	15	6.5	8.5	5.42
K 350-710		3	110	730	560	10	15	9.0	11.7	10.60
K 400-500			130	508	443	6	9	3.6	4.7	3.37
K 400-630			132	620	546	6	9	6.3	8.2	8.21
K 500-630			133	582	520	4	6	4.5	5.9	6.11
K 600-520			145	532	457	4	6	2.5	3.3	7.02
K 600-710			165	736	685	4	6	4.3	5.6	17.0
K 700-900			190	850	738	3	4.5	3.4	4.4	40.0
K 700-901			180	908	760	9	13.5	7.5	9.8	50.0

¹⁾ Allow. operating pressure = inlet pressure + pressure at Q = 0

²⁾ Values for biggest impeller diameter

³⁾ Impeller with water fill

Industrial materials (H, C1, C2)

Pump sizes	Material variants	Impeller				Dry installation (Installation Type "D", "H")		Wet-well installation (Installation Type "S", "P", "K")		Moment of inertia J _{2), 3)} [kgm ²]	
		Impeller channels	Free passage	D _{2max}	D _{2min}	max. operating pressure ¹⁾	max. test pressure	max. operating pressure ¹⁾	max. test pressure		
		qty.	[mm]	[mm]	[mm]	[bar]	[bar]	[bar]	[bar]		
S 50-210	C1, C2	4	7	185	170	-	-	4.3	5.6	0.006	
F 40-250	H, C1, C2	-	25	210	150	-	-	10.0	13.0	0.030	
F 50-210			40	190	170	-	-	3.6	4.7	0.008	
F 65-210			65	195	115	-	-	2.1	2.7	0.014	
F 80-210			80	210	158	-	-	1.4	1.8	0.027	
F 80-250			76	265	190	6	9	6.5	8.5	0.140	
F 100-240			100	190	170	-	-	3.7	4.8	0.130	
F 100-250			100	265	200	6	9	3.6	4.7	0.056	
F 100-315			100	310	270	-	-	4.3	5.6	0.056	
F 100-401			100	390	325	10	15	9.5	12.4	0.248	
F 150-315			120	290	250	6	9	3.5	4.6	0.144	
F 150-401			135	390	270	10	15	9.1	11.8	0.248	
K 50-210		C1, C2	5	7	208	130	-	-	3.6	4.7	0.025
K 40-250		H, C1, C2	3	15	260	150	-	-	10.0	13.0	0.047
K 80-251			33	220	140	-	-	6.7	8.7	0.150	
K 100-250	2		71	256	210	6	9	3.6	4.7	0.070	
K 100-315			80	312	254	-	-	4.3	5.6	0.150	
K 100-401			50	404	310	10	15	9.5	12.4	0.504	
K 150-315			76	310	235	6	9	3.5	4.6	0.180	
K 150-401			76	404	330	10	15	9.1	11.8	0.916	
K 151-401	3		80	404	320	10	15	8.8	11.4	0.520	
K 200-315			70	295	245	6	9	1.9	2.5	0.22	
K 200-316	2		100	305	265	6	9	1.7	2.2	0.22	
K 200-330	3		70	326	287	10	15	5.5	7.2	0.35	
K 200-401			80	404	330	10	15	7.2	9.4	0.52	
K 250-400	3		85	370	300	10	15	7.0	9.1	0.50	
K 250-401	2		105	400	310	10	15	6.0	7.8	0.55	
K 300-400	3		100	408	332	10	15	3.6	4.7	0.75	
K 300-401	2		135	408	367	10	15	2.3	3.0	0.75	

¹⁾ Allow. operating pressure = inlet pressure + pressure at Q = 0

²⁾ Values for biggest impeller diameter

³⁾ Impeller with water fill

Moment of inertia (Rotors)

Motor sizes	Moment of inertia J [kgm ²]	Motor sizes	Moment of inertia J [kgm ²]	Motor sizes	Moment of inertia J [kgm ²]	Motor sizes	Moment of inertia J [kgm ²]	Motor sizes	Moment of inertia J [kgm ²]
5 2	0.01	4 4 / 5 4	0.01	4 6	0.02	10 8	0.09	40 10.N..	1.75
6 2	0.01	7 4	0.02	6 6	0.02	17 8	0.12	60 10.N..	1.93
8 2	0.01	11 4	0.04	9 6	0.05	21 8	0.18	75 10.N..	2.20
12 2	0.02	16 4	0.05	12 6	0.07	26 8	0.37	90 10.N..	2.49
17 2	0.03	4 4.KG / 5 4.KG	0.05	4 6.KG	0.07	35 8	0.47	110 10.N..	7.96
22 2 / 25 2	0.04	7 4.KG	0.06	6 6.KG	0.09	26 8.N..	0.40	150 10.N..	9.66
23 2	0.05	19 4 / 21 4	0.06	15 6	0.09	35 8.N..	0.50	190 10.N..	11.8
37 2	0.13	23 4	0.07	19 6	0.09	50 8.N..	0.66	230 10.N..	17.7
55 2	0.14	29 4	0.11	20 6	0.10	75 8.N..	0.94	270 10.N..	20.5
		35 4	0.22	26 6	0.13	90 8.N..	1.98	310 10.N..	23.2
		50 4	0.25	32 6	0.34	110 8.N..	2.25	350 10.N..	25.8
		65 4	0.30	40 6	0.42	130 8.N..	2.55	390 10.N..	36.1
		35 4.N..	0.25	50 6	0.51	150 8.N..	7.30	430 10.N..	41.6
		50 4.N..	0.28	32 6.N..	0.37	185 8.N..	8.57	475 10.N..	47.2
		65 4.N..	0.33	40 6.N..	0.45	220 8.N..	9.84	535 10.N..	52.7
		80 4.N..	0.46	50 6.N..	0.54	260 8.N..	13.3	600 10.N..	58.2
		95 4.N..	0.55	60 6.N..	0.66	300 8.N..	15.9	660 10.N..	63.7
		110 4.N..	0.63	80 6.N..	0.80	350 8.N..	19.1		
		130 4.N..	1.26	100 6.N..	0.94	400 8.N..	20.7		
		155 4.N..	1.43	120 6.N..	1.89	460 8.N..	31.5		
		175 4.N..	1.57	140 6.N..	2.25	530 8.N..	36.3		
		200 4.N..	3.78	165 6.N..	2.55	580 8.N..	41.1		
		250 4.N..	4.13	190 6.N..	7.30	630 8.N..	45.8	105 12.N..	7.96
		300 4.N..	4.82	225 6.N..	8.57	690 8.N..	50.6	135 12.N..	9.66
		350 4.N..	5.51	260 6.N..	9.84	760 8.N..	55.3	165 12.N..	11.8
				320 6.N..	14.3			195 12.N..	17.7
				360 6.N..	15.9			230 12.N..	20.5
				400 6.N..	17.6			265 12.N..	23.2
				440 6.N..	19.2			290 12.N..	36.1
				480 6.N..	20.7			300 12.N..	25.8
				530 6.N..	31.5			340 12.N..	41.6
				580 6.N..	36.3			380 12.N..	47.2
				630 6.N..	41.1			450 12.N..	52.7
				690 6.N..	45.8			490 12.N..	58.2
				770 6.N..	50.6			560 12.N..	63.7
				850 6.N..	55.3				

Installation Types

KRT K 150-500 / 80 4 UN G - D

S, P, K, D, H

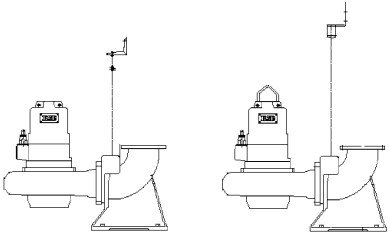
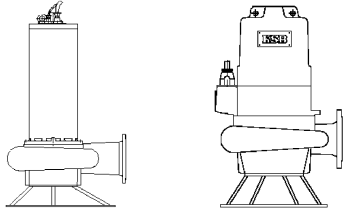
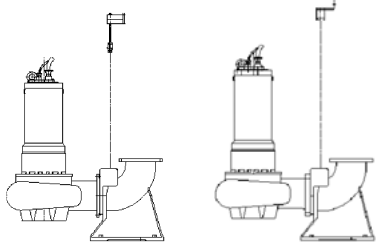
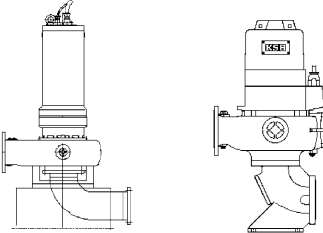
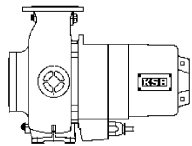
<p>S</p>	<p>Stationary wet-well installation (S1 operation with motor submerged) - with guide wire or guide rails</p>	
<p>P</p>	<p>Transportable wet-well installation (S1 operation with motor submerged)</p>	
<p>K</p>	<p>Stationary wet-well installation (S1 operation with motor outside the fluid) - with guide wire or guide rails</p>	
<p>D</p>	<p>Stationary dry installation, vertical (S1 operation)</p>	
<p>H</p>	<p>Stationary dry installation, horizontal (S1 operation)</p>	

Materials

Material variants

Component	Material version						
	G	G1	G2	GH	H	C1	C2
Pump unit							
Pump casing	JL 1040			JN 3029		1.4517	
Wear Plate (for D-impeller)	JL 1040			-			
Casing wear ring (for E and K impeller)	JL 1040			VG 434			
Impeller (D-impeller JL 1040, with hardened edges)	JL 1040 JS 1030	1.4517	JN 3029			1.4517	
Intermediate casing / discharge cover	JL 1040			JN 3029		1.4517	
Mechanical seal (pump side)	SiC / SiC						
Mechanical seal (motor side)	Carbon / SiC						
Shaft	1.4021 / C45+N (see table, page 15)				1.4021 / 1.4462 / C45+N (see table, page 16)		
Bearing bracket	JL 1040			1.4517			
Motor housing	JL 1040 / 1.0038			1.4517			
Motor housing cover	JL 1040			1.4571		1.4462	
Elastomer components	Nitrile rubber (NBR)					Viton (FPM)	
Bolts	A4 (equivalent to 1.4571)					1.4462	
Cooling jacket	1.4571 / 1.0038			-			
Installation parts							
Duckfoot bend	JL 1040			JN 3029		1.4517	
Claw	JL 1040 or JS 1030 / JS 1050			1.4517			
Mounting bracket	1.4571 up to DN 200; 1.0038 + Z from pump size 200-500					1.4571	
Clamp	1.4571 up to DN 200; JL 1040 from pump size 200-500					1.4571	
Guide wire	1.4401					1.4401 / Tefzel	
Foot plate / feet	1.0038 + Z			1.4571		1.4517 / or 1.4462	
Lifting chain / lifting rope	chain: 1.0038 + Z / 1.4401 / rope: Polyamid / rope: Polypropylene					rope: Polypropylene	

Materials - Information

**Cast Iron
JL 1040 (GG-25)**
Lamellar Graphite Cast Iron

This graphited cast iron to DIN 1691 is mostly used in the pumping of municipal sewage, sludges and rain- or surface water. Suitable for neutral, slightly aggressive media and media unlikely to cause excessive wear. The pH value of the pumped medium should be ≥ 6.5 , sand content ≤ 0.5 g/l.

Duplex Steel
Cast Stainless Steel
(1.4517 or a technically equivalent material)

The resistance to pitting of this ferritic-austenitic stainless cast steel makes it particularly suitable to pump sewage containing substantial amounts of chlorides and acids or sea- and brackish water. Its good chemical resistance, even against sewage containing phosphorus and sulphuric acid, has ensured its wide application in the chemical and process industries. Pumps made from duplex steel have been used very successfully to pump brine, chemical effluents (pH 1 - 12), foul water and seepage from waste disposal sites.

Wear resistant White Iron
(JN3 029 or a technically equivalent material)

A wear resistant white iron for highly abrasive media, such as liquids containing sand, ashes or scale. Its hardness is approximately 61,5 to 68 Rockwell and therefore higher than hardened chromium steel. The alloyed cast iron of chromium- molybdenum has a significantly higher resistance to wear than cast iron JL 1040 (GG-25) or other cast materials.

Material comparison

EN	DIN	ASTM equivalent
JL 1040	GG-25	A 48 Class 40 B
JN 3029	0.9635	A 532 II C 15 % CrMo-Hc
1.4517	1.4517	A 890 CD 4 MCu
1.4021	1.4021	A 276 Type 420
1.4401	1.4401	A 276 Type 316
1.4462	1.4462	A 182 F51
1.4571	1.4571	A 276 Type 316 Ti
C45+N	C 45 N	A 576 Gr. 1045

EN	DIN	ASTM equivalent
1.0038	ST	steel
1.0038 + Z	ST TZN	galv. steel
NBR	NBR	NBR
FPM	FPM	FKM
JS 1030	GGG-40	A 536: 60-40-18
JS 1050	GGG-50	A 536: 60-45-12
VG 434	VG 434	AISI 329

TECHNICAL DATA - STANDARD PROGRAMME / (standard variants)
Material variants G, G1, G2, GH

Motor size						
2-polig	5 2 ... 25 2	37 2 ... 55 2	-	95 4N ... 175 4N	-	-
4-polig	4 4 ... 29 4	35 4 ... 65 4	35 4N ... 80 4N	80 6N ... 165 6N	200 4N ... 350 4 N	-
6-polig	4 6 ... 19 6	32 6 ... 50 6	32 6N ... 60 6N	75 8N ... 130 8N	190 6N ... 480 6N	530 6N ... 850 6N
8-polig	-	26 8, 35 8	26 8N ... 50 8N	40 10N ... 80 10N	150 8N ... 400 8N	460 8N ... 760 8N
10-polig	-	-	-	-	110 10N ... 350 10N	390 10N ... 660 10N
12-polig	-	-	-	-	105 12N ... 300 12N	340 12N ... 560 12N
Shaft material	1.4021		C45+N	1.4021		
Shaft prot. sleeve	-		1.4021			
Bearings	rolling element with lifetime lubrication	rolling element with lifetime lubrication ¹⁾	pump side: rolling element bearings with re-lubrication facility motor side: rolling element with lifetime lubrication			
Explosion protection						
Version U	standard, non-flameproof					
Version X	flameproof, ATEX II 2G T3					-
Version Y	(Var.: II 2G T4)				-	
Version W	non-flameproof					
Motor						
Starting method	direct or star-delta (690 V only direct)					direct
Voltage	400 V (Var.: 380 V, 415 V, 500 V, 690 V)					400 V
Cooling	surrounding pumped liquid		surrounding pumped liquid (Var.: jacket cooling)			
Immersion depth	max. 100 ft					
Power cable	Rubber hose, type see motor catalogue (Var.: EMV-power cable)					
	(Var.: Tefzel = fluoropolymer ETFE modified)		-			
Length	10 m (Var.: up to 50 m)					
Entry	sealed over its entire length					
Sealing						
Elastomers	nitrile rubber NBR (Var. Viton = fluororubber FPM)					
Shaft sealing	bellows-type mechanical seal (Var.: mechanical seal with covered spring)					mechanical seal with covered spring
Monitoring						
Version U, W	one control circuit, i. e. automatic start/stop when reaching the admissible winding temperature					
Version X, Y	same as U, W ; with additional limiting circuit for flameproof equipment					-
Version U, X incl. cooling jacket	-	Winding temperature monitoring Coolant temperature monitoring				
Bearing temp.	-	with PT100 on pump side (Var.: with PT100 on motor side)				pump side and motor side with PT100
Moisture	moisture electrode in motor chamber	moisture electrode in motor chamber				
Mechanical seal - leakage	float switch in leakage area for impeller type D	float switch in leakage area				
Acceleration sensor	-	option				
Paint coat	non-toxic standard KSB coating, colour RAL 5002 (Var.: 250 µm)					
Max. temperature of pumped media						
Version U	40 °C					
Version X, Y	40 °C					-
Version W	60 °C					-
Tests						
Hydraulic tests	ZN 56525 (Var.: impeller types S, D, E, F to ISO 9906/A, impeller type K to ISO 9906/1/2/A)					
General accep. test	ZN 56525 (Var.: with test report EN 10 204-2.2)					
Installation						
stationary with guide wire	Installation depth up to 4.5 m (Var.: up to 30 m; from size 200-500 on up to 15 m)					
transportable	up to size 300-401, except sizes 200-500/501, 200-631, 250-630					-
stationary with guide rail installation	Installation depth up to 4.5 m (Var.: up to 100 ft (30 m))					
stationary, dry	-	with cooling jacket				

¹⁾ for impeller type D: - pump side: rolling element bearings with re-lubrication facility
- motor side: rolling element with lifetime lubrication

TECHNICAL DATA - STANDARD PROGRAMME / (standard variants)
Material variants H, C1, C2

Motor size					
2-pole	01 2 ... 03 2	5 2 ... 25 2	-	-	-
4-pole	01 4 ... 03 4	4 4 ... 29 4	35 4 ... 65 4	80 4	95 4 ... 175 4
6-pole	-	4 6 ... 19 6	32 6 ... 50 6	60 6	80 6 ... 165 6
8-pole	-	-	26 8 ... 35 8	50 8	75 8 ... 130 8
Shaft material for material variants H		1.4021		C45+N	1.4021
Shaft prot. sleeve		-		1.4021	
Shaft material for material variants C1, C2		1.4462 / C45+N		1.4021	
Shaft prot. sleeve		-		1.4462	
Inlet flange (Var.: drilled to DIN 2501)					
Bearings		rolling element with lifetime lubrication		pump side: rolling element bearings with re-lubrication facility motor side: rolling element with lifetime lubrication	
Explosion protection					
Version U		standard, non-flameproof			
Version X		-	ATEX II 2G T3		
Version Y		ATEX II 2G T4	(Var.: ATEX II 2G T4)	-	
Version W		non-flameproof			
Motor					
Starting method		direct	direct or star-delta		
Voltage		400 V (Var.: 230 V, 500 V, 690 V)	400 V (Var.: 380 V, 415 V, 500 V, 690 V)		
Cooling		by surrounding pumped liquid			
Immersion depth		max. 30 m			
Power cable		C2: TEFZEL H, C1: Rubber hose, type see motor catalogue	Rubber hose, type see motor catalogue		
- Special cable		(Var.: TEFZEL = fluoropolymer ETFE modified), (Var.: EMV-cable)			
Length		10 m (Var.: up to 50 m)			
Entry		sealed over its entire length			
Sealing					
Elastomers		nitrile rubber NBR, (Var.: fluororubber), for C2 always fluororubber FPM			
Shaft sealing		C1: bellows-type mechanical seal, (Var.: mech. seal with covered spring) H, C2: mechanical seal with covered spring			
Monitoring					
Version U, W		one control circuit, i. e. automatic start/stop when reaching the admissible winding temperature			
Version X, Y		same as U, W ; with additional limiting circuit for flameproof equipment			
Moisture		moisture electrode in motor chamber			
Paint coat		H: non-toxic KSB standard paint, colour RAL 5002 (Var.: 250 µm 2-comp. epoxy resin) C1, C2: without paint coat			
Max. temperature of pumped media					
Version U		40 °C			
Version X, Y		40 °C			
Version W		60 °C			
Tests					
Hydraulic tests		ZN 56525 (Var.: impeller types S, F to ISO 9906/A, impeller type K to ISO 9906//1/2/A)			
General acceptance test		ZN 56525 (Var.: with test report EN 10 204-2.2)			
Installation					
stationary with guide wire		Installation depth up to 4.5 m (Var.: up to 30 m)			
transportable		Installation depth up to 4.5 m			

Typical sectional drawing

Pump sizes up to 4 kW

Installation types P and S

Example: Amarex KRT F 80-210 / 03 4 YC2

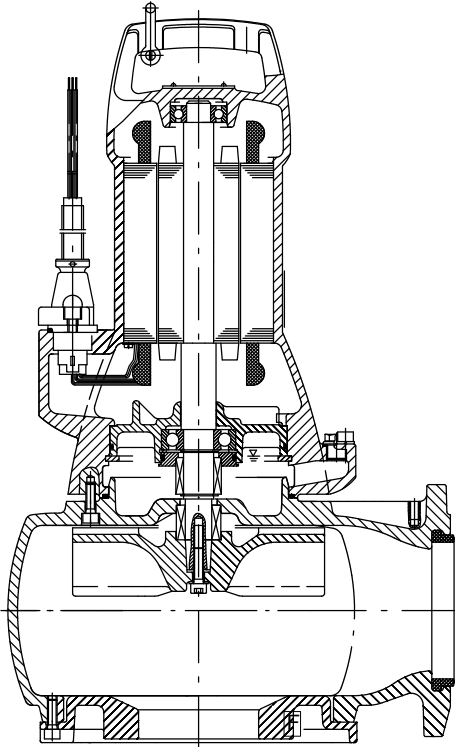

Pump sizes > 4 kW to 30 kW

Installation types D, H, K, P and S

Example: Amarex KRT F 100-250 / 7 4 XG

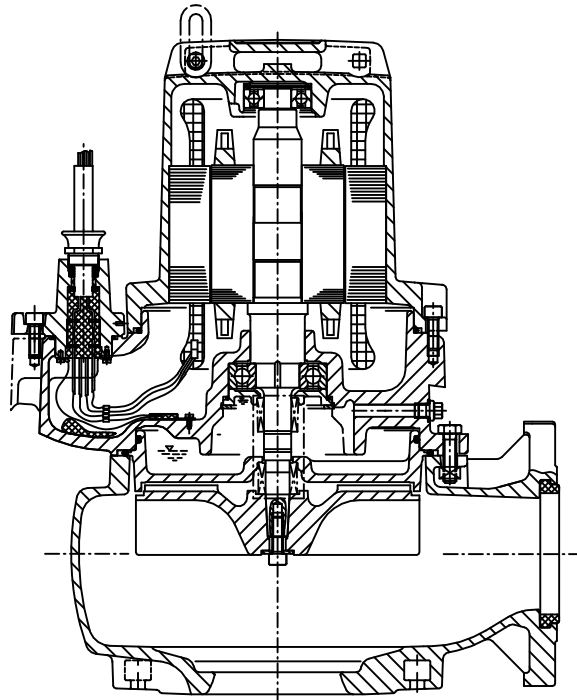

Pump sizes > 30 kW up to approx. 60 kW, installation types P and S

Example: Amarex KRT 150-401 / 65 4 XG

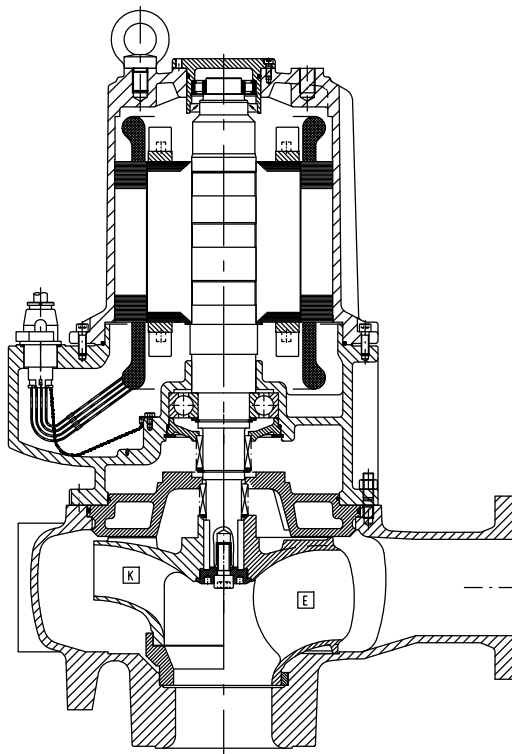

Example: Amarex KRT D 300-400 / 32 6 XG

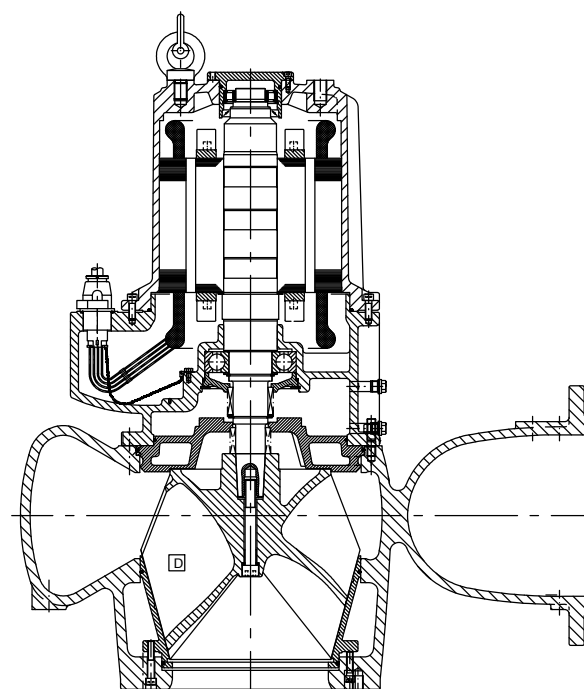

Typical sectional drawing

Pump sizes > 60 kW

Installation types P and S

Example: Amarex KRT K 150-401 / 80 4 XNG-S

Pump sizes > 30 kW

Installation types D and K

Example: Amarex KRT K 150-401 / 80 4 XNG-K

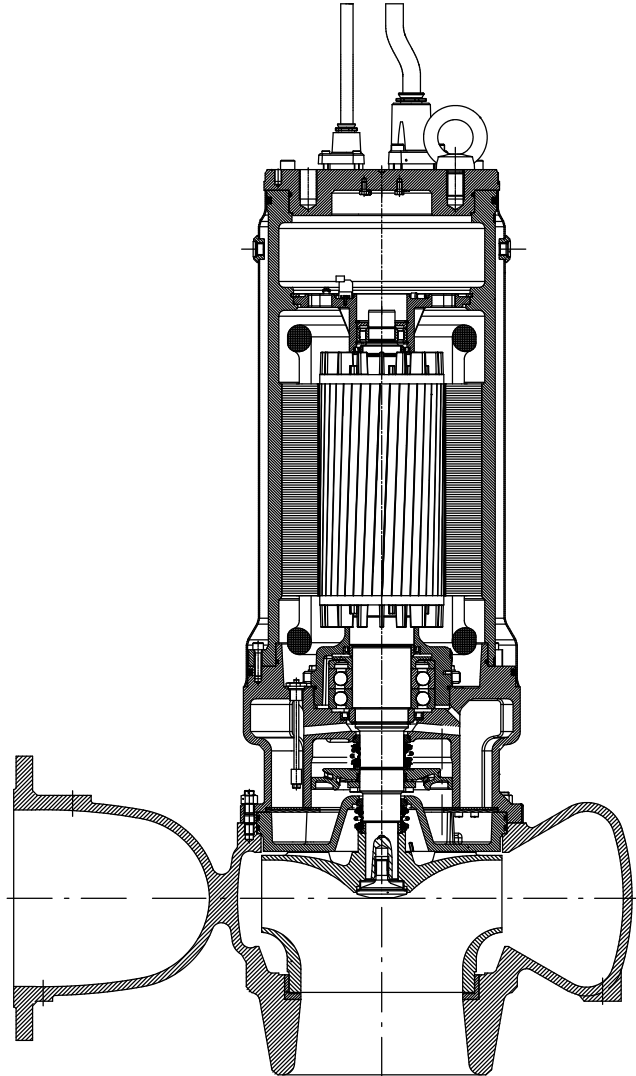
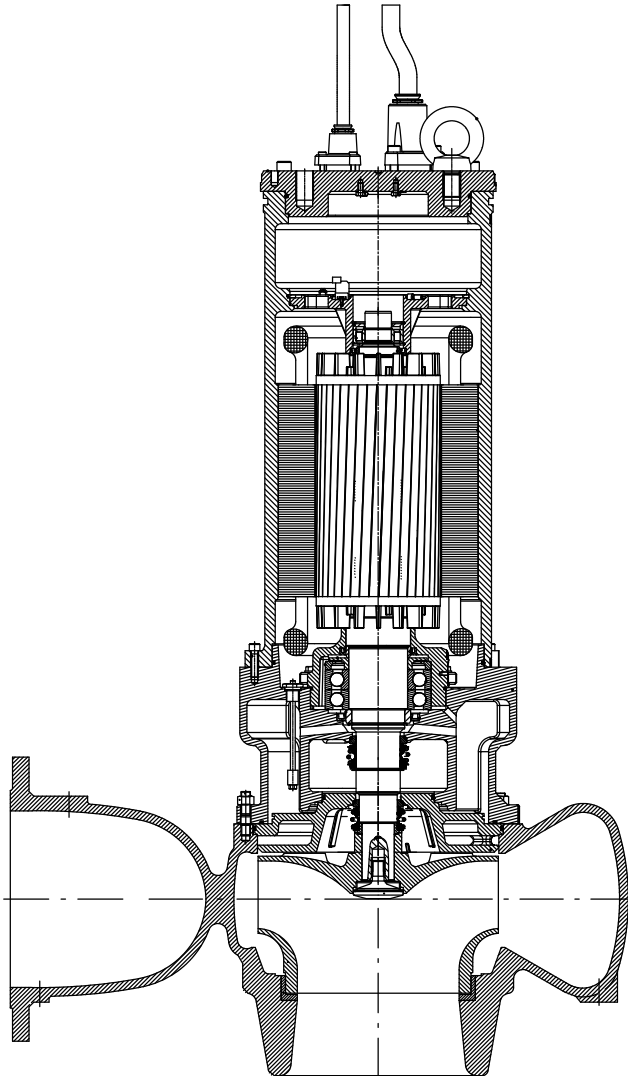

Shaft Seal

Standard version

Mechanical seal with elastomer bellows (NBR, optional: Viton) for all kinds of waste water.

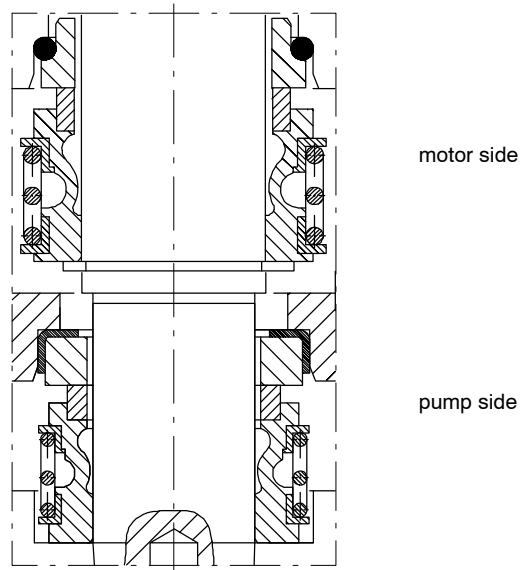

Standard variant

Inboard mechanical seal with covered spring for heavily abrasive products or products containing metal solids (e.g. swarf).

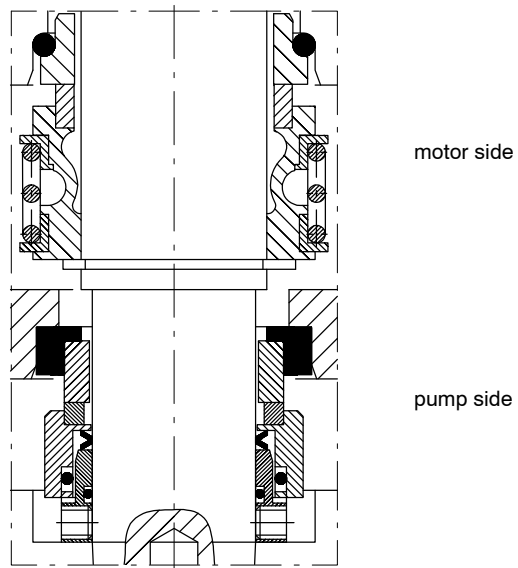

standard for H and C2
(optional for G, G1, G2, GH, C1)



KSB Aktiengesellschaft

P.O. Box 200743 • 06008 Halle (Saale) • Turmstraße 92 • 06110 Halle (Germany)
Tel. +49 (345) 48 26 0 • Fax +49 (345) 48 26 46 99 • www.ksb.com

Jansen Pompentechniek T: +31(0)485-371318 E: info@pompentechniek.nl