

Blokpompen

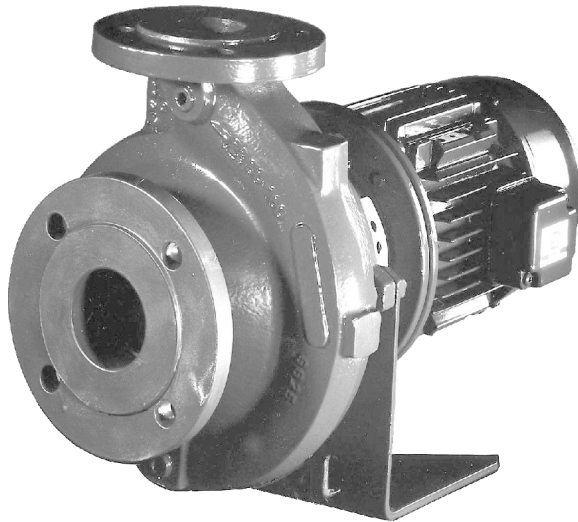

Hoogeindsestraat 5
NL - 5447 PD Rijkevoort
Nederland
T : +31 (0) 485 - 371318
F : +31 (0) 485 - 371918
info@pompentechniek.nl
www.pompentechniek.nl

Automatisering mogelijk met:

- PumpExpert
- PumpDrive (MM)
- Hyamaster
- hyatronic

Toepassingen

- watervoorziening
- beregening
- bevoeiing
- waterafvoer
- Verwarming
- airconditioning
- drinkwater
- tapwater
- heetwater
- koelwater
- zwembadwater
- zeewater
- bluswater
- brakwater
- condensaat
- pekelwater
- oliën
- reinigingsmiddelen

Technische gegevens

	50 Hz	60 Hz
Q	tot 650 m ³ /h, 180 l/s	tot 740 m ³ /h, 205 l/s
H	tot 101 m	tot 97 m
t	-30 tot +140 °C	
p ₂ ¹⁾	tot 16 bar	

1) zie druk-/temperatuurgrenzen blz. 5

Benaming

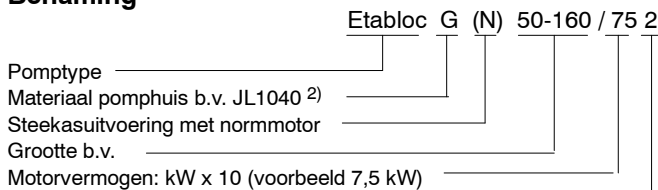

2) volgens EN 1561 = GJL-250

Asafdichting

Mechanische asafdichting volgens EN 12756.

Bouwwijze/uitvoering

Centrifugaalpompe, eentraps³⁾, met capaciteiten volgens EN 733. As in het bereik van de asafdichting met uitwisselbare asbus, pomphuis en waaier met uitwisselbare slijtringen⁴⁾.

3) Etabloc 32-23 tweetraas

4) uitgezonderd Etabloc 25-20 en 32-23

Etabloc GN, MN, SN, BN, CN

Pomp en normmotor zijn tot een blokaggregaat verbonden d.m.v. een flens.

De pompas is star met de motoras verbonden.

Etabloc G, M

Pomp en motor zijn tot een blokaggregaat verbonden d.m.v. een flens, met gemeenschappelijke as.

Certificering

Gecertificeerd kwaliteitsmanagement volgens ISO 9001.

Aandrijving

Standaarduitvoering Etabloc N

oppervlaktegekoelde KSB-IEC-draaistroom-kortsluitankermotor.

Wikkeling: 50Hz	tot 2,2 kW 220-240 V/380-420 V vanaf 3 kW 380-420 V/660-725 V
60Hz	tot 2,6 kW 440-480 V vanaf 3,6 kW 440-480 V

Bouwwijze: tot 4 kW IM V1
vanaf 5,5 kW IM V15

Beschermingsklasse IP 55
Isolatieklasse: F met temperatuurvoeler: 3 PTC voelers
Bedrijfswijze: continubedrijf S1
of

oppervlaktegekoelde draaistroom-kortsluitankermotor zoals hierboven beschreven, echter Westeuropees merkfabrikaat naar onze keuze.

Explosiebeveiligde uitvoering Etabloc N

oppervlaktegekoelde IEC-draaistroom-kortsluitankermotor, Westeuropees merkfabrikaat naar onze keuze.

Wikkeling: 50Hz	tot 1,85 kW 220-240 V/380-420 V ab 2,5 kW 380-420 V/660-725 V
-----------------	--

Bouwwijze: tot 3,3 kW IM V1
vanaf 4,6 kW IM V15

Beschermingsklasse: IP 55 of IP 54
Ontstekings-
beschermklasse: EExe II

Temperatuurklasse: T3
Bedrijfswijze: continubedrijf S1

Standaarduitvoering Etabloc G, M

oppervlaktegekoelde KSB-draaistroom - kortsluitankermotor met verlengde as, met speciale flens.

Wikkeling: 50Hz	tot 2,2 kW: 220-240 V / 380-420 V vanaf 3 kW: 380-420 V / 660-725 V
60Hz	tot 2,6 kW 440-480 V vanaf 3,6 kW 440-480 V

Bouwwijze: tot 4 kW: zonder voet
vanaf 5,5 kW: met voet

Beschermingsklasse IP 55
Isolatieklasse: F met temperatuurvoeler: 3 PTC voelers
Bedrijfswijze: continubedrijf S1

Bescherming tegen aanraking

Afdekplaten aan aandrijflantaarn volgens EN 294.

Grafieken

n = 2900 1/min

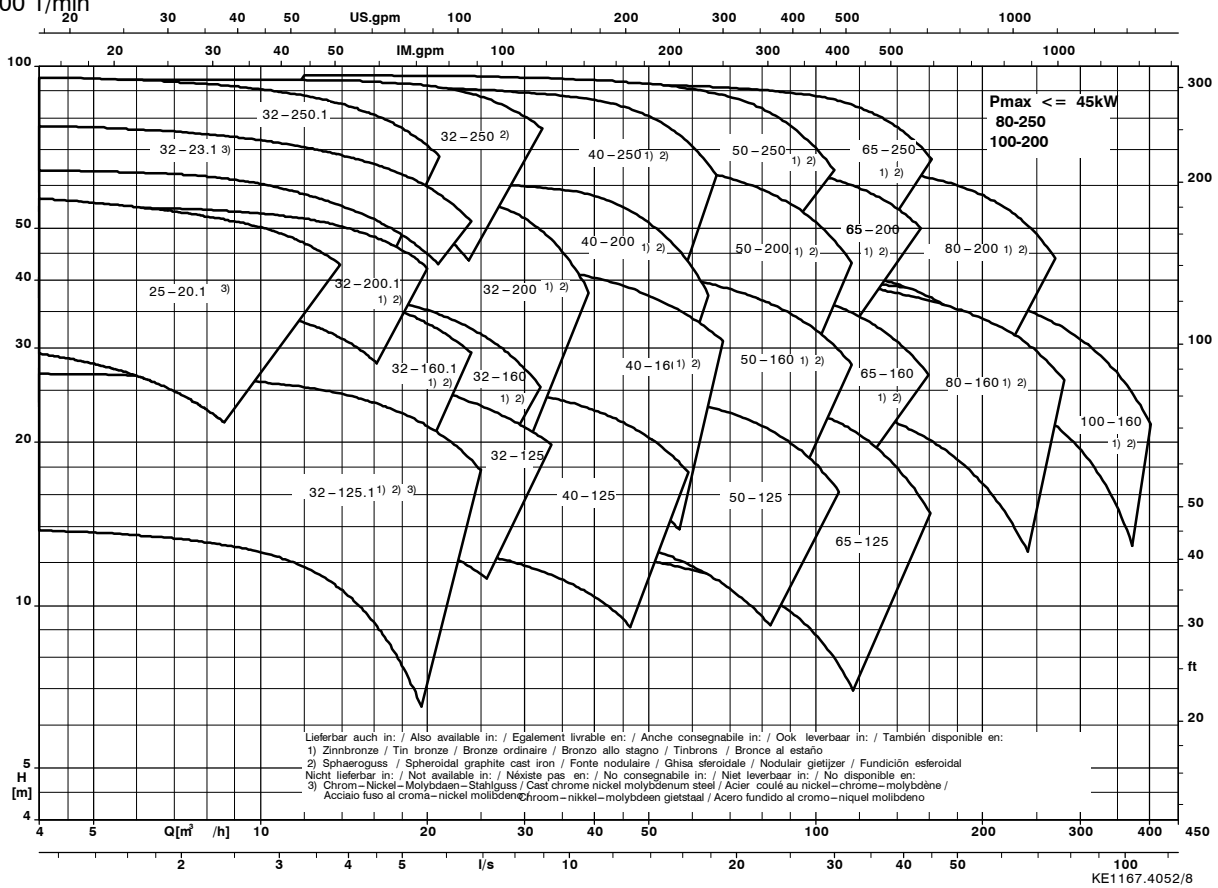

n = 1450 1/min

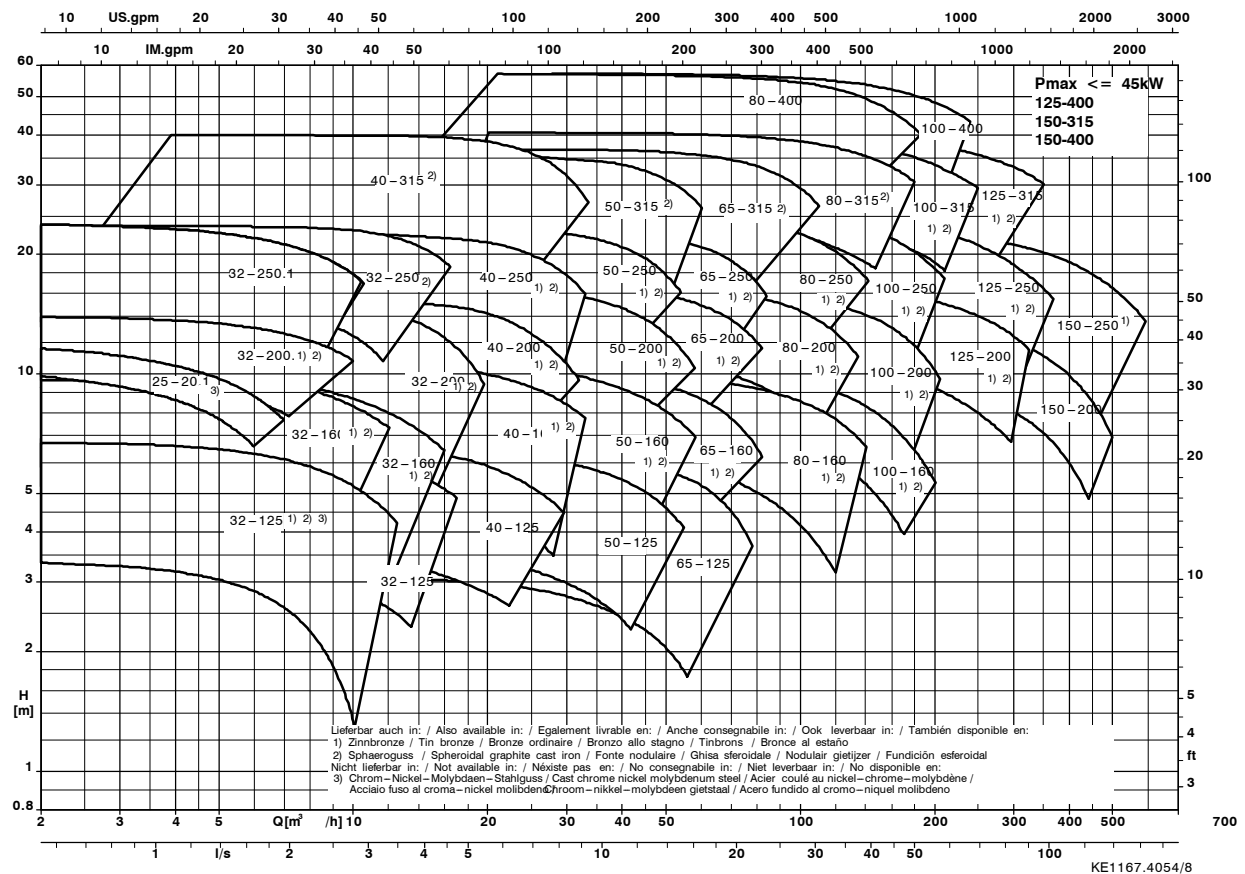

Grafieken

n = 3500 1/min

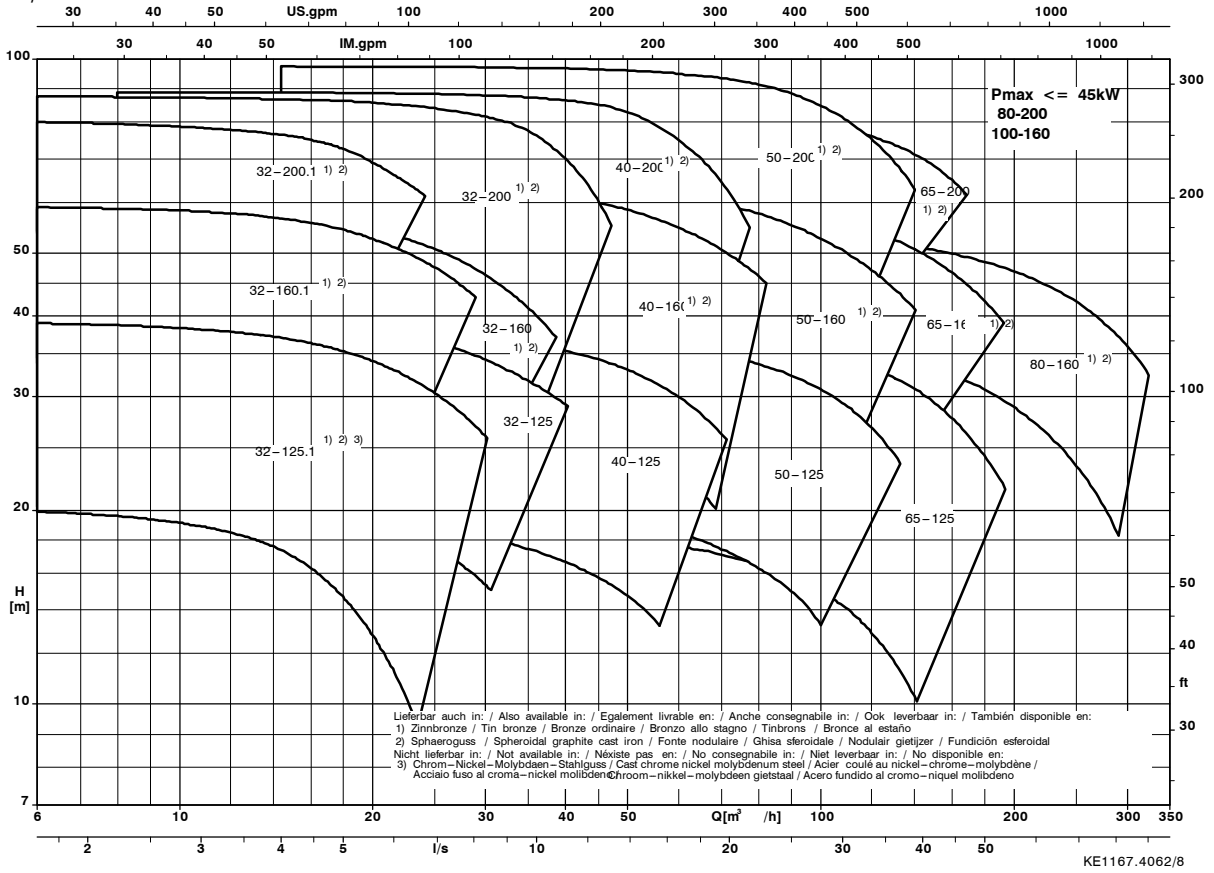

n = 1750 1/min

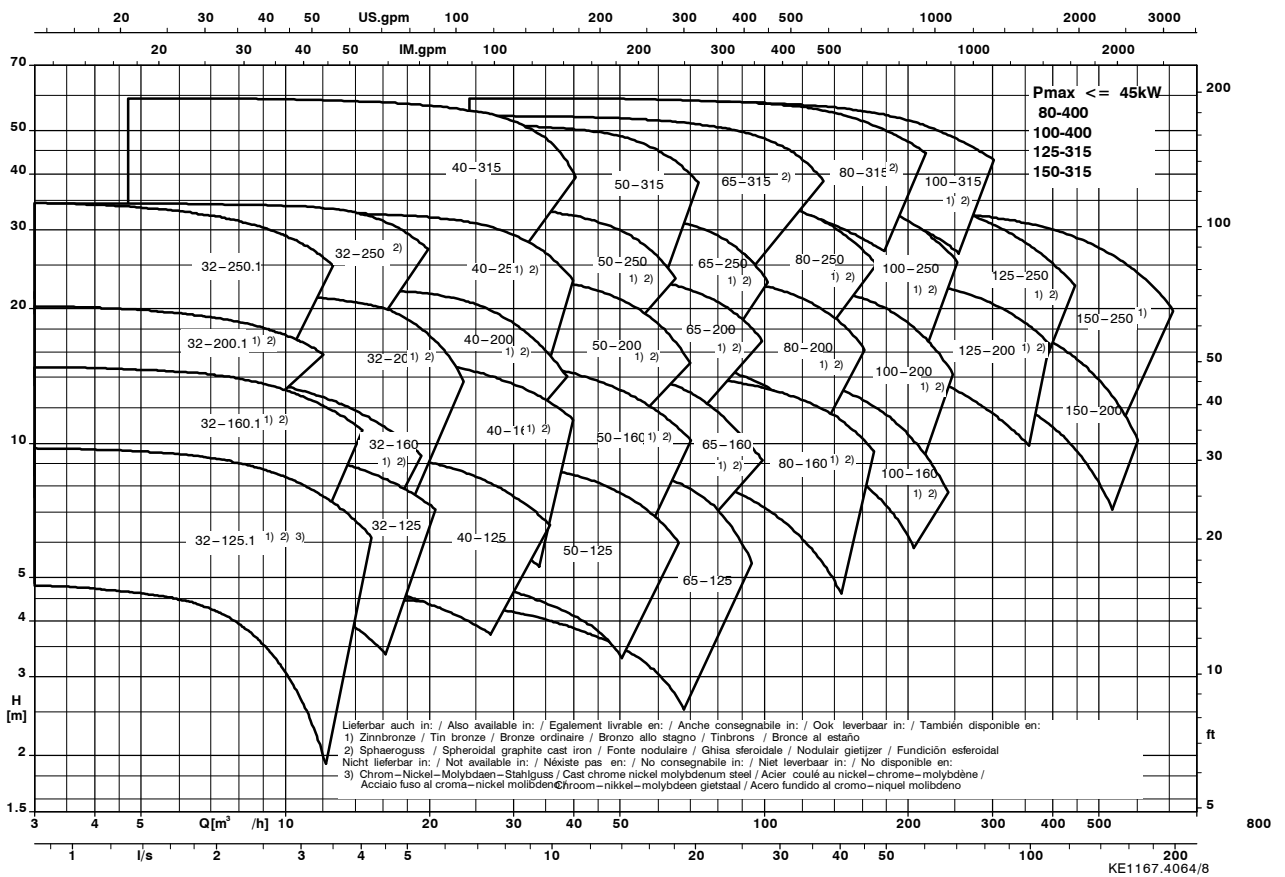

Materialen

	Etabloc G, GN	Etabloc M, MN	Etabloc BN
Pomphuis	Gietijzer JL1040 ¹⁾	Gietijzer JL1040 ¹⁾	Tinbrons CC480K-GS ³⁾
Drukdeksel	Gietijzer JL1040 ¹⁾	Gietijzer JL1040 ¹⁾	Tinbrons CC480K-GS ³⁾
Waaier	Gietijzer JL1040 ¹⁾	Tinbrons CC480K-GS ³⁾	Tinbrons CC480K-GS ³⁾
Slijtringen	Gietijzer JL1040	Gietijzer/Brons GG/CC495K-GS ³⁾	Brons CC495K-GS ³⁾
As	TemperstaalC45N	TemperstaalC45N	Chroom-nikkel-molybdeen-staal 1.4571
Asbus	Chroom-nikkel-molybdeen-staal 1.4571	Chroom-nikkel-molybdeen-staal 1.4571	Chroom-nikkel-molybdeen-staal 1.4571
Aandrijflantaarn	Gietijzer JL1040 ¹⁾	Gietijzer JL1040 ¹⁾	Gietijzer JL1040 ¹⁾

	Etabloc SN	Etabloc CN
Pomphuis	nodulair gietijzer JS1025 ²⁾	Chroom- nikkel- molybdeen- staal 1.4408
Drukdeksel	nodulair gietijzer JS1025 ²⁾	Chroom- nikkel- molybdeen- staal 1.4408
Waaier	Gietijzer JL1040 ¹⁾	Chroom-nikkel-molybdeen-staal 1.4408
Slijtringen	Gietijzer JL1040	Chroom-nikkel-molybdeen-staal 1.4408
As	TemperstaalC45N	Chroom-nikkel-molybdeen-staal 1.4571
Asbus	Chroom-nikkel-molybdeen-staal 1.4571	Chroom-nikkel-molybdeen-staal 1.4571
Aandrijflantaarn	Gietijzer JL1040 ¹⁾	Gietijzer JL1040 ¹⁾

- 1) volgens EN 1561 = GJL-250
 2) volgens EN 1563 = GJS-400-18-LT
 3) volgens EN 1982

Etabloc N

grote keuze in materiaal-uitvoering, gietijzer, tinbrons, nodulair gietijzer, chroom-nikkel-molybdeen-staal

Asbus
voorkomt slijtage aan de as

Servicevriendelijke, robuuste KSB-IEC-draaistroommotor

Slijtringen servicevriendelijk, geen slijtage aan het huis/de waaier

Waaier
met geoptimaliseerde hydrauliek, hoog rendement

Toevoergeometrie
geconstrueerd voor goede zuigeigenschappen (NPSH) en lage cavitatiegevoeligheid

Drukdeksel berekend voor 16 bar voor hoge bedrijfszekerheid

Bedrijfszekere **mechanische asafdichting**, onderhoudsvrij

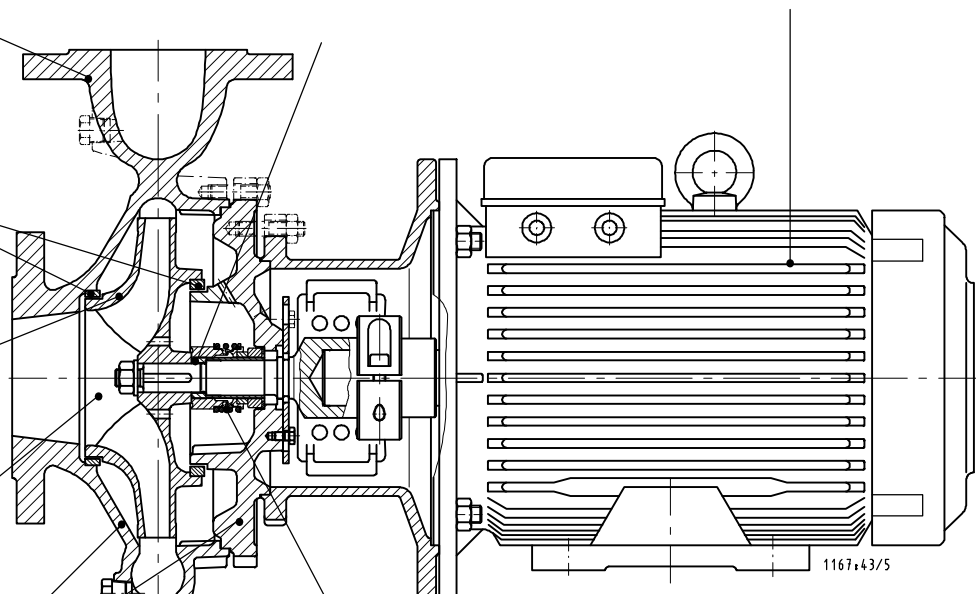

Druk- en temperatuurgrenzen

Etabloc	Mediumtemperatuur ¹⁾⁴⁾	Einddruk p_2 ²⁾	Testdruk ³⁾
G, GN	-30 °C tot +140 °C		tot 21 bar
M, MN	-30 °C tot +140 °C	⁵⁾	tot 21 bar
SN	-30 °C tot +140 °C		tot 25 bar
BN	-30 °C tot +140 °C	10 bar	tot 13 bar
CN	-30 °C tot +140 °C	⁵⁾	tot 21 bar

- 1) Bij heetwaterinstallaties volgens DIN 4752, paragraaf 4.5, toepassingsgebieden in acht nemen
- 2) De som van de toeloopdruk en de opvoerhoogte in het capaciteitsnulpunt mag de in de tabel aangegeven waarden niet overschrijden
- 3) De huisdelen worden door interne testen volgens AN 1897/75-03 met water op dichtheid getest
- 4) Bij mediumtemperatuur > 140 °C dient Etabloc SY, Etaline SY ingezet te worden
- 5) zie tabel

Druk-/temperatuurafhankelijkheid voor flenzen volgens EN 1092-1 en EN 1092-2

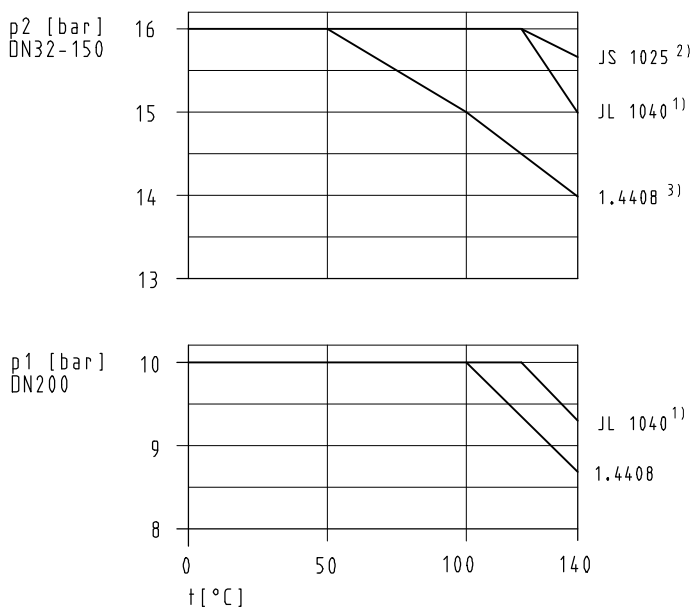

- 1) volgens EN 1561 = JL1040
- 2) volgens EN 1563 = JS1025
- 3) alleen DN 65-150; DN 32-50 = 16 bar

Leverbare grootte-gerelateerde materialen

Pompgrootte	Etabloc						
	G	GN	M	MN	SN	BN	CN
25-20.1/...	X	X	X	X	-	-	-
32-23.1/...	X	X	X	X	-	-	-
32-125.1/...	X	X	X	X	X	X	X
32-160.1/...	X	X	X	X	X	X	X
32-200.1/...	X	X	X	X	X	X	X
32-250.1/...	X	X	X	X	-	-	X
32-125/...	X	X	X	X	-	-	X
32-160/...	X	X	X	X	X	X	X
32-200/...	X	X	X	X	X	X	X
32-250/...	X	X	X	X	X	-	X
40-125/...	X	X	X	X	-	-	X
40-160/...	X	X	X	X	X	X	X
40-200/...	X	X	X	X	X	X	X
40-250/...	X	X	X	X	X	X	X
40-315/...	X	X	X	X	X	-	X
50-125/...	X	X	X	X	-	-	X
50-160/...	X	X	X	X	X	X	X
50-200/...	X	X	X	X	X	X	X
50-250/...	X	X	X	X	X	X	X
50-315/...	X	X	X	X	X	-	X
65-125/...	X	X	X	X	-	-	X
65-160/...	X	X	X	X	X	X	X
65-200/...	X	X	X	X	X	X	X
65-250/...	X	X	X	X	X	X	X
65-315/...	X	X	X	X	X	-	X
80-160/...	X	X	X	X	X	X	X
80-200/...	X	X	X	X	X	X	X
80-250/...	X	X	X	X	X	X	X
80-315/...	X	X	X	X	X	-	X
80-400/...	X	X	X	X	-	-	X
100-160/...	X	X	X	X	X	X	X
100-200/...	X	X	X	X	X	X	X
100-250/...	X	X	X	X	X	X	X
100-315/...	X	X	X	X	X	X	X
100-400/...	X	X	X	X	-	-	X
125-200/...	X	X	X	X	X	X	X
125-250/...	X	X	X	X	X	X	X
125-315/...	X	X	X	X	X	X	X
125-400/...	X	X	X	X	X	-	X
150-200/...	X	X	X	X	-	-	X
150-250/...	X	X	X	X	-	X	X
150-315/...	X	X	X	X	X	X	X

Medium	Toepas- singsgebied	Materiaal huis/waaier										Uitvoeringscode	Aanwijzing		
		Gietijzer/Gietijzer		Gietijzer/Tinbrons		Nodular gietijzer/Gietijzer		Tinbrons/Tinbrons		CrNiMo-gietstaal/ CrNiMo-gietstaal				Asafdichting Mechanische asafdichting	
		G, GN	M, MN	SN	BN	CN	6	9	10	11	12				
Water															
Bluswater ¹⁾	t ≤ 60 °C ⁶⁾ p ≤ 10 bar		X								X		M10, MN10	Navraag noodzakelijk als VdS-gewenst is	
Brakwater ³⁾	t ≤ 25 °C p ≤ 10 bar				X					X			BN10	Chroom-nikkel-molybdeen-gietstaal mogelijk	
Condensaat niet geconditio- neerd	t ≤ 120 °C p ≤ 10 bar					X					X		CN11		
Condensaat ²⁾	t ≤ 120 °C p ≤ 10 bar	X									X		G11, GN11		
Drinkwater ¹⁾	t ≤ 60 °C ⁷⁾ p ≤ 10 bar		X								X		MN11		
Gedeeltelijk ontzout water ²⁾	t ≤ 120 °C p ≤ 10 bar	X									X		G11, GN11		
Koelwater ¹⁾ (zonder antivries)	t ≤ 60 °C ⁶⁾ p ≤ 10 bar	X								X			G10, GN10	open kringloop: M10/MN10 toepassen	
Koelwater pH-waarde ≥ 7,5 (met antivries)	t ≤ 30-110 °C p ≤ 10 bar	X									X		G11, GN11	open kringloop: M11/MN11 toepassen	
Licht verontreinigd water ¹⁾	t ≤ 60 °C ⁶⁾ p ≤ 10 bar	X								X			G10, GN10		
Onbehandeld water ¹⁾	t ≤ 60 °C ⁶⁾ p ≤ 10 bar	X								X			G10, GN10		
Schoon water ⁵⁾	t ≤ 60 °C ⁷⁾ p ≤ 10 bar	X									X		G11, GN11		
Stuwmeerwater ¹⁾	t ≤ 60 °C ⁶⁾ p ≤ 10 bar		X							X			MN10	bij het verpompen van media met vaste deeltjes is navraag noodzakelijk	
Verwarmingswater ²⁾	t ≤ 120 °C p ≤ 10 bar	X									X		G11, GN11	Bij toepassing als circulatiepomp volgens DIN 4752: p _{max} ≥ 10 bar Bij het verpompen van visceuze media: "S"	
Verwarmingswater ²⁾	t ≤ 140 °C p ≤ 16 bar	X						X					G6, GN6		
Verwarmingswater ²⁾	t ≤ 110 °C p ≤ 10 bar	X								X			G10, GN10		
Volledig ontzout (VE-) water	t ≤ 120 °C p ≤ 10 bar					X					X		CN11	aan allerhoogste reinheidseisen kan niet worden vol- daan	
Volledig ontzout (VE-) water als ketelvoedingwater ²⁾	t ≤ 120 °C p ≤ 10 bar	X									X		G11, GN11		
Zeewater ³⁾	t ≤ 25 °C p ≤ 10 bar				X					X			BN10	Chroom-nikkel-molybdeen-gietstaal mogelijk	
Zwembadwater; zeewater ³⁾	t ≤ 40 °C p ≤ 10 bar				X					X			BN10	Chroom-nikkel-molybdeen-gietstaal bij t ≤ +25 °C mogelijk	
Zwembadwater; zoetwater ¹⁾	t ≤ 60 °C p ≤ 10 bar	X								X			G10, GN10	geldt ook bij eisen volgens DIN 19 643	
Koelvloeistof, koelmiddel															
Koelmiddel, anorganisch pH-waarde ≤ 7,5	t -30-+25 °C p ≤ 10 bar	X									X		G11, GN11		
Water met antivries pH- waarde ≥ 7,5 ¹⁾⁵⁾	t -30-+110 °C p ≤ 10 bar	X									X		G11, GN11		

- algemene beoordelingscriteria voor wateranalyse: pH-waarde ≥ 7; Chloridegehalte (Cl) ≤ 250 mg/kg, chloor (Cl₂) ≤ 0,6 mg/kg.
- behandeld volgens VdTUV 1466, extra geldt O₂ ≤ 0,02 mg/l
- voor onderdelen van brons geldt:
ammoniak (NH₃) ≤ 5 mg/kg, vrij van zwavelwaterstof (H₂S); daardoor kan de beperking van het Cl-gehalte vervallen.
Bij het niet aanhouden van de grenswaarden, KSB raadplegen.
- antivries op ethyleen-glycolbasis met inhibitors, gehalte: >20 % tot 50 % (bijv. antifrogeen N)
- Geen schoonwater met allerhoogste reinheidseisen!
Geleidbaarheid bij 25 °C: ≤ 800 µS/cm, corrosiechemisch neutraal
- mechanische asafdichting toegestaan voor t ≤ 110 °C
- mechanische asafdichting toegestaan voor t ≤ 120 °C

Keuzevoorbeeld:

 Gegeven: schoon water 15 °C; Q = 50 m³/h; H = 20 m

Gevonden:

Etabloc GN 40 - 125/402 GN 11

Materiaal resp. uitvoeringsvarianten

(volgens bovenstaande tabel)

Grootte (volgens grafiek 2900 1/min)

Uitvoeringscode (volgens bovenstaande tabel)

Medium	Toepassingsgebied	Materiaal huis/waaier					Asafdichting Mechanische asafdichting			Uitvoeringscode	Aanwijzing
		Gietijzer/Gietijzer	Gietijzer/Tinbrons	Nodulair gietijzer/Gietijzer	Tinbrons/Tinbrons	CrNiMo-gietijzer/CrNiMo-gietijzer	U3U3VGG	Q1Q1X4GG	Q1Q1M1 GG		
		G, G N	M, MN	SN	BN	CN	9	10	12		
Oliën/emulsies											
Boor-/slijpemulsies	$t \leq 60^\circ\text{C}$ $p \leq 10\text{ bar}$	X					X		G9, GN9		
Dieselolie, stookolie EL	$t \leq 60^\circ\text{C}$ $p \leq 10\text{ bar}$			X				X	SN10	Gietijzer mogelijk, als er geen bepaalde eisen zijn	
Olie-Water-emulsie	$t \leq 60^\circ\text{C}$ $p \leq 16\text{ bar}$	X					X		G9, GN9		
Smeerolie, turbineolie, geldt niet voor SF-D-oliën (moeilijk brandbaar)	$t \leq 80^\circ\text{C}$ $p \leq 10\text{ bar}$			X				X	SN10	Bij eisen "zonder" inwendige grondverf, fabriek raadplegen. Gietijzer mogelijk, als er geen bepaalde eisen zijn	
Reinigingsmiddelen											
Waslogen voor flessenspoelers	$t \leq 90^\circ\text{C}$ $p \leq 10\text{ bar}$	X							G7, GN7	Q ₁ Q ₁ EGG	
Inzetten bij brouwerijen											
Bierbeslag	$t \leq 100^\circ\text{C}$ $p \leq 10\text{ bar}$	X						X	GN 12	Bij gevaar voor drooglopen door overmatig legen van het reservoir dient een Etabloc of Etanorm met dubbele pakking in tandem-opstelling ingezet te worden	
Bierwort	$t \leq 100^\circ\text{C}$ $p \leq 10\text{ bar}$	X						X	GN 12		

Keuzevoorbeeld:

 Gegeven: stookolie EL 15 °C; Q = 50 m³/h; H = 20 m

Gevonden:

Etabloc SN 40 - 125/402 SN 10

 Materiaal resp uitvoeringsvarianten
(volgens bovenstaande tabel)

Grootte (volgens grafiek 2900 1/min)

Uitvoeringscode (volgens bovenstaande tabel)

Etabloc G, M 25-20.1, 32-23.1

Medium	Toepassingsgebied	Materiaal Huis Waaier ³⁾		Asafdichting Mechanische asafdichting			Uitvoering	Aanwijzing
		Gietijzer/ Gietijzer	Gietijzer/ Tinbrons	U3U3VGG	Q1Q1X4GG	BQ1EGG		
		G	M	9	10	11		
Water								
Bluswater ¹⁾	t ≤ 60 °C ⁶⁾ p ≤ 10 bar		X		X		M10	Navraag noodzakelijk als VdS-gewenst is
Condensaat ²⁾	t ≤ 110 °C p ≤ 10 bar	X				X	G11	
Drinkwater ¹⁾	t ≤ 60 °C ⁷⁾ p ≤ 10 bar		X			X	M11	
Gedeeltelijk ontzout water ²⁾	t ≤ 120 °C p ≤ 10 bar	X				X	G11	
Koelwater ¹⁾ (zonder antivries)	t ≤ 60 °C ⁶⁾ p ≤ 10 bar	X			X		G10	open kringloop : M 10 toepassen
Koelwater pH-waarde ≥ 7,5 (met antivries) ⁴⁾	t -30-+110 °C p ≤ 10 bar	X				X	G11	open kringloop: M 11 toepassen
Licht verontreinigd water ¹⁾	t ≤ 60 °C ⁶⁾ p ≤ 10 bar	X			X		G10	
Ongehandeld water ¹⁾	t ≤ 60 °C ⁶⁾ p ≤ 10 bar	X			X		G10	
Schoon water	t ≤ 60 °C ⁷⁾ p ≤ 10 bar	X				X	G11	geen allerhoogste reinheidseisen
Stuwmeerwater ¹⁾	t ≤ 60 °C ⁶⁾ p ≤ 10 bar		X		X		M10	bij het verpompen van media met vaste deeltjes is navraag noodzakelijk
Verwarmingswater ²⁾	t ≤ 110 °C p ≤ 10 bar	X				X	G10	Bij toepassing als circulatiepomp volgens DIN 4752 P _{max} ≤ 10 bar
Volledig ontzout (VE-) water als ketelvoedingwater ²⁾	t ≤ 120 °C p ≤ 10 bar	X				X	G11	
Zwembadwater ¹⁾ zoetwater	t ≤ 60 °C p ≤ 10 bar	X			X		G10	geldt ook voor eisen volgens DIN 19643
Koelvloeistof, koelmiddelen								
Koelmiddelen, anorganisch pH-Wert ≥ 7,5	t -30-+25 °C p ≤ 10 bar	X				X	G11	
Water met antivries pH-Wert ≥ 7,5 ¹⁾⁵⁾	t -30-+110 °C p ≤ 10 bar	X				X	G11	
Oliën/emulsies								
Boor-/slijpemulsies	t ≤ 60 °C p ≤ 10 bar	X		X			G9	
Olie-Water-emulsie	t ≤ 60 °C p ≤ 10 bar	X		X			G9	
Reinigingsmiddelen								
Waslogen voor flessenspoelers	t ≤ 90 °C p ≤ 10 bar	X					G7	Q ₁ Q ₁ EGG

- algemene beoordelingscriteria voor wateranalyse: pH-waarde ≥ 7; chloridegehalte (Cl) ≤ 250 mg/kg, chloor (Cl₂) ≤ 0,6 mg/kg.
- behandeld volgens VdTÜV 1466, extra geldt O₂ ≤ 0,02 mg/l
- voor onderdelen van brons geldt: ammoniak (NH₃) ≤ 5 mg/kg, vrij van zwavelwaterstof (H₂S); daardoor kan de beperking van het Cl-gehalte vervallen. bij het niet opvolgen van de grenswaarden, KSB raadplegen.
- antivriesmiddelen op ethyleen-glycolbasis met inhibitors. gehalte: >20 % tot 50 % (z.B. Antifrogen N)
- geleidbaarheid bij 25 °C: ≤ 800 μS/cm, corrosiechemisch neutral
- mechanische asafdichting toegestaan voor t ≤ 110 °C
- mechanische asafdichting toegestaan voor t ≤ 120 °C

Keuzevoorbeeld:

 Gegeven: schoon water 15 °C; Q = 10 m³/h; H = 41 m

Gevonden:

	Etabloc G 25 - 20.1/302 G 11
Materiaal resp. uitvoeringsvarianten	
(volgens bovenstaande tabel)	
Grootte (volgens grafiek 2900 1/min)	
Uitvoeringscode (volgens bovenstaande tabel)	

Etabloc	Ⓜ	50 Hz	60 Hz	50Hz, 400V; 60Hz, 460V; ≈A ²)
		kW	kW	
2 - polig				
25-20.1/152	90S	1,5		3,4
25-20.1/222	90L	2,2		4,6
25-20.1/302	100L	3,0		6,3
25-20.1/402	112M	4,0		8,3
32-23.1/402 ¹⁾	112M	4,0		8,3
32-23.1/552 ¹⁾	112L	5,5		11
32-125.1/072	80	0,75		1,8
32-125.1/112	80	1,1	1,3	2,6
32-125.1/152	90S	1,5	1,75	3,4
32-125.1/222	90L	2,2	2,55	4,6
32-125.1/302	100L		3,45	6,3
32-125.1/402	112M		4,6	8,3
32-125.1/552	132S		6,3	11
32-160.1/152	90S	1,5		3,4
32-160.1/222	90L	2,2	2,55	4,6
32-160.1/302	100L	3,0	3,45	6,3
32-160.1/402	112M	4,0	4,6	8,3
32-160.1/552	132S		6,3	11
32-160.1/752	132S		8,6	14,6
32-200.1/302	100L	3,0		6,3
32-200.1/402	112M	4,0	4,6	8,3
32-200.1/552	132S	5,5	6,3	11
32-200.1/752	132S		8,6	14,6
32-200.1/1102	160M		12,6	20,7
32-200.1/1502	160M		17,3	28
32-250.1/552	132S	5,5		11
32-250.1/752	132S	7,5		14,6
32-250.1/1102	160M	11		20,7
32-250.1/1502	160M	15		28
32-125/112	80	1,1		2,6
32-125/152	90S	1,5	1,75	3,4
32-125/222	90L	2,2	2,55	4,6
32-125/302	100L	3,0	3,45	6,3
32-125/402	112M		4,6	8,3
32-125/552	132S		6,3	11
32-160/222	90L	2,2		4,6
32-160/302	100L	3,0	3,45	6,3
32-160/402	112M	4,0	4,6	8,6
32-160/552	132S		6,3	11
32-160/752	132S		8,6	14,6
32-200/402	112M	4,0		8,3
32-200/552	132S	5,5	6,3	11
32-200/752	132S	7,5	8,6	14,6
32-200/1102	160M	11	12,6	20,7
32-200/1502	160M		17,3	28
32-250/752	132S	7,5		14,6
32-250/1102	160M	11		20,7
32-250/1502	160M	15		28
40-125/152	90S	1,5		3,4
40-125/222	90L	2,2	2,55	4,6
40-125/302	100L	3,0	3,45	6,3
40-125/752	132S		8,6	65,0
40-125/1102	160M		12,6	14,6
40-160/302	100L	3,0		6,3
40-160/402	112M	4,0	4,6	8,3
40-160/552	132S	5,5	6,3	11
40-125/402	112M	4,0	4,6	8,3
40-125/552	132S		6,3	11
40-160/752	132S	7,5	8,6	14,6
40-160/1102	160M	11	12,6	20,7
40-160/1502	160M		17,3	28
40-200/552	132S	5,5		11

Etabloc	Ⓜ	50 Hz	60 Hz	50Hz, 400V; 60Hz, 460V; ≈A ²)
		kW	kW	
2 - polig				
40-200/752	132S	7,5	8,6	14,6
40-200/1102	160M	11	12,6	20,7
40-200/1502	160M	15	17,3	28
40-200/1852	160L		21,3	33
40-200/2202	180M		24,5	40
40-250/1102	160M	11		20,7
40-250/1502	160M	15		28
40-250/1852	160L	18,5		33
40-250/2202	180M	22		40
50-125/302	100L	3,0		6,3
50-125/402	112M	4,0		8,3
50-125/552	132S	5,5	6,3	11
50-125/752	132S	7,5	8,6	14,6
50-125/1102	160M		12,6	20,7
50-125/1502	160M		17,3	28
50-160/552	132S	5,5	6,3	11
50-160/752	132S	7,5	8,6	14,6
50-160/1102	160M	11	12,6	20,7
50-160/1502	160M	15	17,3	28
50-160/1852	160L		21,3	33
50-160/2202	180M		24,5	40
50-200/1102	160M	11	12,6	20,7
50-200/1502	160M	15	17,3	28
50-200/1852	160L	18,5	21,3	33
50-200/2202	180M	22	24,5	40
50-200/3002	200L		34,5	54
50-200/3702	200L		42,5	65
50-250/1502	160M	15		28
50-250/1852	160L	18,5		33
50-250/2202	180M	22		40
50-250/3002	200L	30		54
50-250/3702	200L	37		65
65-125/402	112M	4,0		8,3
65-125/552	132S	5,5	6,3	11
65-125/752	132S	7,5	8,6	14,6
65-125/1102	160M	11	12,6	20,7
65-125/1502	160M		17,3	28
65-160/752	132S	7,5		14,6
65-160/1102	160M	11	12,6	20,7
65-160/1502	160M	15	17,3	28
65-160/1852	160L		21,3	33
65-160/2202	180M		24,5	40
65-160/3002	200L		34,5	54
65-200/1502	160M	15		28
65-200/1852	160L	18,5	21,3	33
65-200/2202	180M	22	24,5	40
65-200/3002	200L		34,5	54
65-200/3702	200L		42,5	65
65-250/2202	180M	22		40
65-250/3002	200L	30		54
65-250/3702	200L	37		65
65-250/4502	225M	45		78
80-160/1102	160M	11		20,7
80-160/1502	160M	15		28
80-160/1852	160L	18,5		33
80-160/2202	180M	22	24,5	40
80-160/3002	200L	30	34,5	54
80-160/3702	200L		42,5	65
80-200/1852	160L	18,5		33
80-200/2202	180M	22		40
80-200/3002	200L	30		54
80-200/3702	200L	37		65

1) tweetraps

2) De aangegeven stroomwaarden in A zijn geschatte waarden. De exacte waarden kunt u van het typeplaatje op de motor aflezen.

Etabloc	(M)	50 Hz kW	60 Hz kW	50Hz, 400V; 60Hz, 460V; ≈A ²)
2 - polig				
80-200/4502	225M	45	52	78
80-250/3002	200L	30		54
80-250/3702	200L	37		65
80-250/4502	225M	45		78
100-160/2202	180M	22		40
100-160/3002	200L	30		54
100-160/3702	200L	37	42,5	65
100-160/4502	225M		52	78
100-200/3002	200L	30		54
100-200/3702	200L	37		65
100-200/4502	225M	45		78

Etabloc	(M)	50 Hz kW	60 Hz kW	50Hz, 400V; 60Hz, 460V; ≈A ²)
4 - polig				
25-20.1/034	71	0,37		1,2
32-125.1/024	71	0,25	0,30	0,8
32-125.1/034	71	0,37	0,43	1,2
32-125.1/054	80	0,55	0,63	1,6
32-160.1/034	71	0,37	0,43	1,2
32-160.1/054	80	0,55	0,63	1,6
32-160.1/074	80		0,88	2,0
32-160.1/114	90S		1,30	2,8
32-200.1/054	80	0,55	0,63	1,6
32-200.1/074	80	0,75	0,88	2,0
32-200.1/114	90S		1,30	2,8
32-200.1/154	90L		1,75	3,6
32-200.1/224	100L		2,55	5,1
32-250.1/074	80	0,75		2,0
32-250.1/114	90S	1,1	1,30	2,8
32-250.1/154	90L	1,5	1,75	3,6
32-250.1/224	100L		2,55	5,1
32-250.1/304	100L		3,45	6,7
32-125/034	71	0,37	0,43	1,2
32-125/054	80	0,55	0,63	1,6
32-125/074	80		0,88	2,0
32-160/054	80	0,55	0,63	1,6
32-160/074	80		0,88	2,0
32-160/114	90S		1,30	2,8
32-200/054	80	0,55		1,6
32-200/074	80	0,75	0,88	2,0
32-200/114	90S	1,1	1,30	2,8
32-200/154	90L		1,75	3,6
32-200/224	100L		2,55	5,1
32-250/114	90S	1,1		2,8
32-250/154	90L	1,5		3,6
32-250/224	100L	2,2	2,55	5,1
32-250/304	100L		3,45	6,7
32-250/404	112M		4,60	8,8
32-250/554	132S		6,30	11,5
40-125/024	71	0,25		0,8
40-125/034	71	0,37		1,2
40-125/054	80	0,55	0,63	1,6
40-125/074	80		0,88	2,0
40-125/114	90S		1,30	2,8
40-160/054	80	0,55		1,6
40-160/074	80	0,75	0,88	2,0
40-160/114	90S	1,1	1,30	2,8
40-160/154	90L		1,75	3,6
40-160/224	100L		2,55	5,1

Etabloc	(M)	50 Hz kW	60 Hz kW	50Hz, 400V; 60Hz, 460V; ≈A ²)
4 - polig				
40-200/074	80	0,75		2,0
40-200/114	90S	1,1		2,8
40-200/154	90L	1,5	1,75	3,6
40-200/224	100L		2,55	5,1
40-200/304	100L		3,45	6,7
40-250/114	90S	1,1		2,8
40-250/154	90L	1,5		3,6
40-250/224	100L	2,2	2,55	5,1
40-250/304	100L	3,0	3,45	6,7
40-250/404	112M		4,60	8,8
40-250/554	132S		6,30	11,5
40-315/224	100L	2,2		5,1
40-315/304	100L	3,0		6,7
40-315/404	112M	4,0	4,6	8,8
40-315/554	132S	5,5	6,3	11,5
40-315/754	132M		8,6	15,5
40-315/1104	160M		12,6	21,5
50-125/054	80	0,55		1,6
50-125/074	80	0,75	0,88	2,0
50-125/114	90S	1,1	1,30	2,8
50-125/154	90L		1,75	3,6
50-160/074	80	0,75		2,0
50-160/114	90S	1,1	1,30	2,8
50-160/154	90L	1,5	1,75	3,6
50-160/224	100L		2,55	5,1
50-160/304	100L		3,45	6,7
50-200/154	90L	1,5		3,6
50-200/224	100L	2,2	2,55	5,1
50-200/304	100L	3,0	3,45	6,7
50-200/404	112M		4,60	8,8
50-200/554	132S		6,30	11,5
50-250/224	100L	2,2		5,1
50-250/304	100L	3,0		6,7
50-250/404	112M	4,0	4,6	8,8
50-250/554	132S		6,3	11,5
50-250/754	132M		8,6	15,5
50-250/1104	160M		12,6	21,5
50-315/1504	160L		17,3	28,5
65-125/054	80	0,55		1,6
65-125/074	80	0,75	0,88	2,0
65-125/114	90S	1,1	1,30	2,8
65-125/154	90L		1,75	3,6
65-125/224	100L		2,55	5,1
65-160/114	90S	1,1		2,8
65-160/154	90L	1,5	1,75	3,6
65-160/224	100L	2,2	2,55	5,1
65-160/304	100L		3,45	6,7
65-160/404	112M		4,60	8,8
65-200/224	100L	2,2		5,1
65-200/304	100L	3,0		6,7
65-200/404	112M	4,0	4,6	8,8
65-200/554	132S		6,3	11,5
65-200/754	132M		8,6	15,5
65-250/304	100L	3,0		6,7
65-250/404	112M	4,0		8,8
65-250/554	132S	5,5	6,3	11,5
65-250/754	132M		8,6	15,5

1) tweetraps

2) De aangegeven stroomwaarden zijn geschatte waarden. De exacte waarden kunt u van het typeplaatje op de motor aflezen.

Etabloc	Ⓜ	50 Hz kW	60 Hz kW	50Hz, 400V; 60Hz, 460V; ≈A ²)
4 - polig				
65-250/1104	160M		12,6	21,5
65-315/554	132S	5,5		11,5
65-315/754	132M	7,5		15,5
65-315/1104	160M	11	12,6	21,5
65-315/1504	160L	15	17,3	28,5
65-315/1854	180M		21,3	35
65-315/2204	180L		25,3	42
80-160/154	90L	1,5		3,6
80-160/224	100L	2,2		5,1
80-160/304	100L	3,0		6,7
80-160/404	112M	4,0	4,6	8,8
80-160/554	132S		6,3	15,5
80-200/224	100L	2,2		5,1
80-200/304	100L	3,0		6,7
80-200/404	112M	4,0		8,8
80-200/554	132S	5,5	6,3	11,5
80-200/754	132M		8,6	15,5
80-200/1104	160M		12,6	21,5
80-250/404	112M	4,0		8,8
80-250/554	132S	5,5		11,5
80-250/754	132M	7,5	8,6	15,5
80-250/1104	160M	11	12,6	21,5
80-250/1504	160L		17,3	28,5
80-250/1854	180M		21,3	35
80-315/754	132M	7,5		15,5
80-315/1104	160M	11		21,5
80-315/1504	160L	15	17,3	28,5
80-315/1854	180M	18,5	21,3	35
80-315/2204	180L	22	25,3	42
80-315/3004	200L		34,5	56
80-315/3704	225S		42,5	67
80-400/3004	200L	30	34,5	56
80-400/3704	225S		42,5	67
80-400/4504	225M		52	81
100-160/304	100L	3,0		6,7
100-160/404	112M	4,0		8,8
100-160/554	132S	5,5	6,3	11,5
100-160/754	132M		8,6	15,5
100-200/404	112M	4,0		8,8
100-200/554	132S	5,5		11,5
100-200/754	132M	7,5	8,6	15,5
100-200/1104	160M		12,6	21,5
100-200/1504	160L		17,3	28,5
100-250/754	132M	7,5		15,5
100-250/1104	160M	11	12,6	21,5
100-250/1504	160L	15	17,3	28,5
100-250/1854	180M		21,3	35
100-250/2204	180L		25,3	42
100-315/1504	160L	15		28,5
100-315/1854	180M	18,5	21,3	35
100-315/2204	180L	22	25,3	42
100-315/3004	200L	30	34,5	56
100-315/3704	225S		42,5	67
100-315/4504	225M		52	81
100-400/3004	200L	30		56
100-400/3704	225S	37	42,5	67
100-400/4504	225M		52	81
125-200/754	132M	7,5		15,5
125-200/1104	160M	11	12,6	21,5
125-200/1504	160L	15	17,3	28,5
125-200/1854	180M		21,3	35
125-200/2204	180L		25,3	42

Etabloc	Ⓜ	50 Hz kW	60 Hz kW	50Hz, 400V; 60Hz, 460V; ≈A ²)
4 - polig				
125-250/1104	160M	11		21,5
125-250/1504	160L	15	17,3	28,5
125-250/1854	180M	18,5	21,3	35
125-250/2204	180L	22	25,3	42
125-250/3004	200L		34,5	56
125-250/3704	225S		42,5	67
125-315/3004	200L	30		56
125-315/3704	225S	37	42,5	67
125-315/4504	225M		52	81
125-400/3004	200L	30		56
125-400/3704	225S	37		67
125-400/4504	225M	45		81
150-200/754	132M	7,5		15,5
150-200/1104	160M	11		21,5
150-200/1504	160L	15	17,3	28,5
150-200/1854	180M		21,3	35
150-200/2204	180L		25,3	42
150-250/1504	160L	15		28,5
150-250/1854	180M	18,5		35
150-250/2204	180L	22	25,3	42
150-250/3004	200L	30	34,5	56
150-250/3704	225S		42,5	67
150-250/4504	225M		52	81
150-315/3004	200L	30		56
150-315/3704	225S	37	42,5	67
150-315/4504	225M	45	52	81

2) De aangegeven stroomwaarden zijn geschatte waarden. De exacte stroom waarden kunt u van het typeplaatje op de motor aflezen.

Etabloc G, M

tot motorgrootte 112 = 4 kW

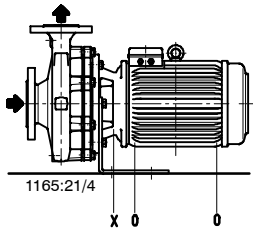

Afleveringstoestand
Horizontale inbouw, bevestiging onder

tot motorgrootte 112 = 4 kW

motorgrootte 132 = 5,5 kW tot 180 = 22 kW

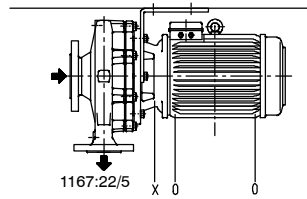
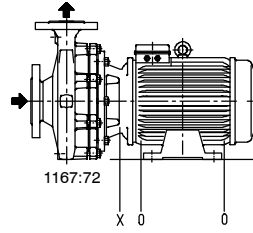

Verticale inbouw met motor boven, navraag noodzakelijk

Stand van de condenswatergaten o = open
x = gesloten

Horizontale inbouw, bevestiging boven.
Motor moet 180° gedraaid worden

Etabloc GN, MN, BN¹⁾, SN¹⁾, CN¹⁾

tot motorgrootte 112 = 4 kW

motorgrootte 132 = 5,5 kW
tot 180 = 22 kW

Etabloc GN, MN, BN¹⁾, SN¹⁾

bij Etabloc CN navraag noodzakelijk

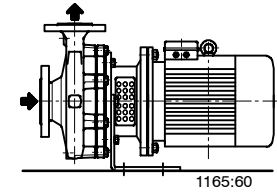

Afleveringstoestand
Horizontale inbouw, bevestiging onder

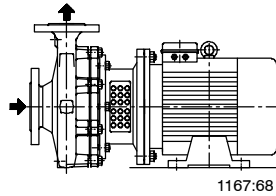

motorgrootte
112 = 4 kW

motorgrootte
132 = 5,5 kW
tot 180 = 22 kW

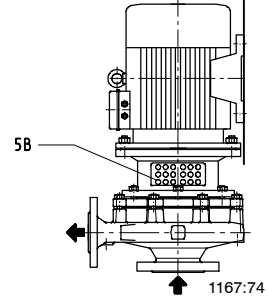
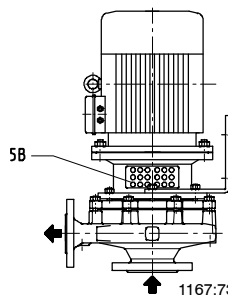

Bij verticale inbouw dient ter voorkoming van drooglopen van de mechanische asafdichting een ontluuchtingsventiel geplaatst te worden.

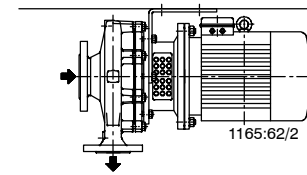

Horizontale inbouw, bevestiging boven.
Motor moet 180° gedraaid worden.

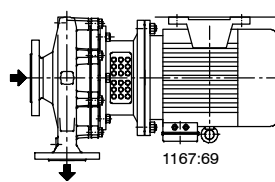

Etabloc GN¹⁾, MN¹⁾, SN¹⁾, CN¹⁾

tot motorgrootte 200 = 30 kW tot 225 = 45 kW

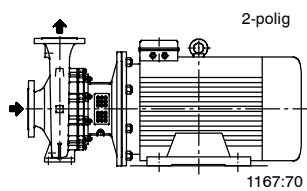

Afleveringstoestand
Horizontale inbouw, bevestiging onder

1) Pomphuis met voet

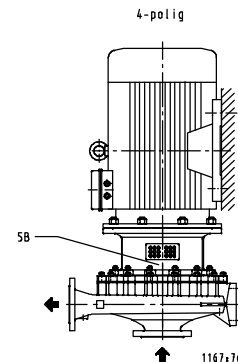
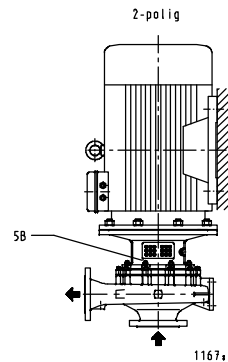
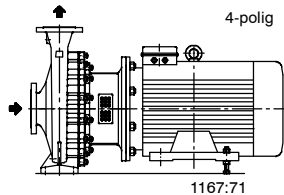

Bij verticale inbouw dient ter voorkoming van drooglopen van de mechanische asafdichting een ontluuchtingsventiel geplaatst te worden

Etabloc G, M 25-20.1/... bis 32-160//..., n = 2900 1/min, n = 3500 1/min

mit Stützfuß (bis Motorbaugröße 112 = 4 kW)
 mit Motorfuß (ab Motorbaugröße 132 = 5,5 kW)
 with support foot (up to motor size 112 = 4 kW)
 with motor foot (motor size 132 = 5.5 kW and above)
 avec béquille (jusqu'à taille de moteur 112 = 4 kW)

avec pied de moteur (à partir de la taille de moteur 132 = 5,5 kW)
 con piede angolare (fino alla grandezza del motore 112 = 4 kW)
 con piede di fusione (a partire della grandezza del motore 132 = 5,5 kW)
 met voetsteun (tot motorgrootte 112 = 4 kW)
 met motorvoet (vanaf motorgrootte 132 = 5,5 kW)

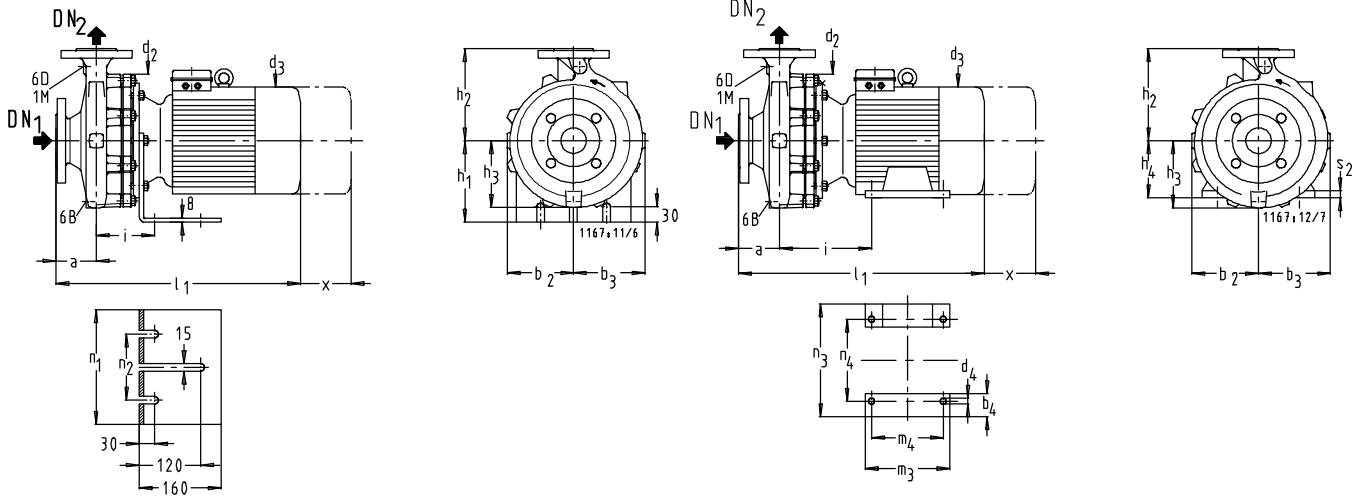

		Etabloc G, M		Etabloc SN, CN	
		Etabloc GN, MN, BN	DN ₂ 32 - DN ₂ 100	DN ₂ 32 - DN ₂ 80	DN ₂ 100 - DN ₂ 150
1 M	Druckmessgerät-Anschluss / Pressure gauge connection / Indicateur de pression / Manomètre / Manometro / Manometer	Rc 3/8 ¹⁾	Rc 1/2 ¹⁾	G 3/8 ¹⁾	G 1/2 ¹⁾
6 B	Förderflüssigkeit-Entleerung / Casing drain / Vidange du liquide pompé / Scarico del liquido convogliato / Vloeistof- aftap	Rc 3/8 ¹⁾	Rc 1/2 ¹⁾	G 3/8 ¹⁾	G 1/2 ¹⁾
6 D	Förderflüssigkeit-Auffüllen und Entlüften / Filling and venting of medium handled / Remplissage et purge d'air du liquide pompé / Riempimento del liquido convogliato spurgo dell'aria / Vloeistof vullen en ontluften	Rc 3/8 ¹⁾	Rc 1/2 ¹⁾	G 3/8 ¹⁾	G 1/2 ¹⁾

mm

Etabloc G, M	M	n = 2900	n = 3500	Toleranz der Anschlussmaße nach EN 735																							
				DN ₁	DN ₂	a	b ₂ ≈	b ₃ ≈	b ₄ ≈	d ₂	d ₃ ≈	d ₄	h ₁	h ₂	h ₃	h ₄	i	l ₁ ≈	m ₃ ≈	m ₄	n ₁	n ₂	n ₃ ≈	n ₄	s ₂	x	
25-20.1/152	90S	x		40	25	90	140	140		215	178		150	175	140		105	436			214	130					145
25-20.1/222	90L	x		40	25	90	140	140		215	178		150	175	140		105	361			214	130					145
25-20.1/302	100L	x		40	25	90	140	140		215	198		150	175	140		105	486			214	130					145
25-20.1/402	112M	x		40	25	90	140	140		215	222		150	175	140		105	507			214	130					145
32-23.1/402 ³⁾	112M	x		40	32	122	125	135		215	222		150	175	130		80	497			214	130					
32-23.1/552 ³⁾	112L	x		40	32	122	125	135		215	222		150	175	130		80	542			214	130					
32-125.1/072	80	x		50	32	80	113	113		225	160		160	140	103		118	426			225	130					100
32-125.1/112	80	x	x	50	32	80	113	113		225	160		160	140	103		118	426			225	130					100
32-125.1/152	90S	x	x	50	32	80	113	113		225	178		160	140	103		118	461			225	130					100
32-125.1/222	90L	x	x	50	32	80	113	113		225	178		160	140	103		118	461			225	130					100
32-125.1/302	100L	x	x	50	32	80	113	113		225	198		160	140	103		118	508			225	130					100
32-125.1/402	112M	x	x	50	32	80	113	113		225	222		160	140	103		118	530			225	130					100
32-125.1/552	132S	x	x	50	32	80	113	113	43	225	265	12		140	103	132	193	557	220	140			270	216	15	100	
32-160.1/152	90S	x		50	32	80	116	125		225	178		160	160	115		118	461			225	130					100
32-160.1/222	90L	x	x	50	32	80	116	125		225	178		160	160	115		118	461			225	130					100
32-160.1/302	100L	x	x	50	32	80	116	125		225	198		160	160	115		118	508			225	130					100
32-160.1/402	112M	x	x	50	32	80	116	125		225	222		160	160	115		118	530			225	130					100
32-160.1/552	132S	x	x	50	32	80	116	125	43	225	265	12		160	115	132	193	557	220	140			270	216	15	100	
32-160.1/752	132S	x	x	50	32	80	116	125	43	225	265	12		160	115	132	193	557	220	140			270	216	15	100	
32-200.1/302	100L	x		50	32	80	128	137		275	198		160	180	130		118	508			225	130					100
32-200.1/402	112M	x	x	50	32	80	128	137		275	222		160	180	130		118	530			225	130					100
32-200.1/552	132S	x	x	50	32	80	128	137	43	275	265	12		180	130	132	193	557	220	140			270	216	15	100	
32-200.1/752	132S	x	x	50	32	80	128	137	43	275	265	12		180	130	132	193	557	220	140			270	216	15	100	
32-200.1/1102	160M	x	x	50	32	80	128	137	70	275	323	14		180	130	160	200	650	300	210			320	254	21	100	
32-200.1/1502	160M	x	x	50	32	80	128	137	70	275	323	14		180	130	160	200	650	300	210			320	254	21	100	
32-250.1/552 ⁴⁾	132S	x		50	32	100	164	171	43	320	265	12		225	162	132	193	577	220	140			270	216	15	100	
32-250.1/752 ⁴⁾	132S	x		50	32	100	164	171	43	320	265	12		225	162	132	193	577	220	140			270	216	15	100	
32-250.1/1102 ⁴⁾	160M	x		50	32	100	164	171	70	320	323	14		225	162	160	200	670	300	210			320	254	21	100	
32-250.1/1502 ⁴⁾	160M	x		50	32	100	164	171	70	320	323	14		225	162	160	200	670	300	210			320	254	21	100	
32-125/112	80	x		50	32	80	113	113		225	160		160	140	103		118	426			225	130					100
32-125/152	90S	x	x	50	32	80	113	113		225	178		160	140	103		118	461			225	130					100
32-125/222	90L	x	x	50	32	80	113	113		225	178		160	140	103		118	461			225	130					100
32-125/302	100L	x	x	50	32	80	113	113		225	198		160	140	103		118	508			225	130					100
32-125/402	112M	x	x	50	32	80	113	113		225	222		160	140	103		118	530			225	130					100
32-125/552	132S	x	x	50	32	80	113	113	43	225	265	12		140	103	132	193	557	220	140			270	216	15	100	
32-160/222	90L	x		50	32	80	113	125		225	178		160	160	115		118	461			225	130					100
32-160/302	100L	x	x	50	32	80	113	125		225	198		160	160	115		118	508			225	130					100
32-160/402	112M	x	x	50	32	80	113	125		225	222		160	160	115		118	530			225	130					100
32-160/552	132S	x	x	50	32	80	113	125	43	225	265	12		160	115	132	193	557	220	140			270	216	15	100	
32-160/752	132S	x	x	50	32	80	113	125	43	225	265	12		160	115	132	193	557	220	140			270	216	15	100	

1) Rc = ISO 7/1; 2) EN 1092-2/DN../PN 16/21/JL1040/B 3) zweistufig/two stages/2 étages/a due stadi/tweetraps 4) \triangle h₃ ≥ h₄
 G = ISO 228/1

Etabloc G, M 32-200/... bis 50-125/..., n = 2900 1/min, n = 3500 1/min

mit Stützfuß (bis Motorbaugröße 112 = 4 kW)
 mit Motorfuß (ab Motorbaugröße 132 = 5,5 kW)
 with support foot (up to motor size 112 = 4 kW)
 with motor foot (motor size 132 = 5.5 kW and above)
 avec béquille (jusqu'à taille de moteur 112 = 4 kW)

avec pied de moteur (à partir de la taille de moteur 132 = 5,5 kW)
 con piede angolare (fino alla grandezza del motore 112 = 4 kW)
 con piede di fusione (a partire della grandezza del motore 132 = 5,5 kW)
 met voetsteun (tot motorgrootte 112 = 4 kW)
 met motorvoet (vanaf motorgrootte 132 = 5,5 kW)

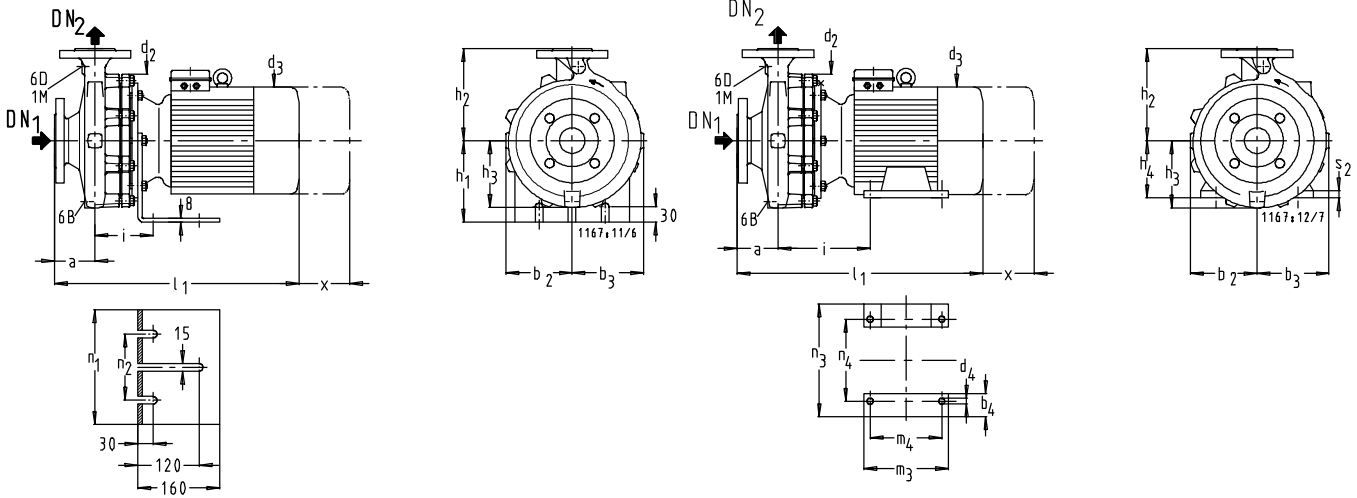

		Etabloc G, M		Etabloc SN, CN	
		Etabloc GN, MN, BN	DN ₂ 32 - DN ₂ 80	DN ₂ 100	DN ₂ 32 - DN ₂ 80
1 M	Druckmessgerät-Anschluss / Pressure gauge connection / Indicateur de pression / Manomètre / Manometro / Manometer	Rc 3/8 ¹⁾	Rc 1/2 ¹⁾	G 3/8 ¹⁾	G 1/2 ¹⁾
6 B	Förderflüssigkeit-Entleerung / Casing drain / Vidange du liquide pompé / Scarico del liquido convogliato / Vloeistof- aftap	Rc 3/8 ¹⁾	Rc 1/2 ¹⁾	G 3/8 ¹⁾	G 1/2 ¹⁾
6 D	Förderflüssigkeit-Auffüllen und Entlüften / Filling and venting of medium handled / Remplissage et purge d'air du liquide pompé / Riempimento del liquido convogliato spurgo dell'aria / Vloeistof vullen en ontluften	Rc 3/8 ¹⁾	Rc 1/2 ¹⁾	G 3/8 ¹⁾	G 1/2 ¹⁾

mm

Etabloc G, M	Ⓜ	n = 2900	n = 3500	Toleranz der Anschlussmaße nach EN 735																						
				DN ₁ 2)	DN ₂ 2)	a	b ₂ ≈	b ₃ ≈	b ₄ ≈	d ₂	d ₃ ≈	d ₄	h ₁	h ₂	h ₃	h ₄	i	l ₁ ≈	m ₃ ≈	m ₄	n ₁	n ₂	n ₃ ≈	n ₄	s ₂	x
32-200/402	112M	x		50	32	80	132	141		275	222		160	180	133	132	193	557	220	140			270	216	15	100
32-200/552 ⁴⁾	132S	x	x	50	32	80	132	141	43	275	265	12		180	133	132	193	557	220	140			270	216	15	100
32-200/752 ⁴⁾	132S	x	x	50	32	80	132	141	43	275	265	12		180	133	132	193	557	220	140			270	216	15	100
32-200/1102	160M	x	x	50	32	80	132	141	70	275	323	14		180	133	160	200	650	300	210			320	254	21	100
32-200/1502	160M		x	50	32	80	132	141	70	275	323	14		180	133	160	200	650	300	210			320	254	21	100
32-250/752 ⁴⁾	132S	x		50	32	100	170	176	43	320	265	12		225	168	132	193	577	220	140			270	216	15	100
32-250/1102 ⁴⁾	160M	x		50	32	100	170	176	70	320	323	14		225	168	160	200	670	300	210			320	254	21	100
32-250/1502 ⁴⁾	160M	x		50	32	100	170	176	70	320	323	14		225	168	160	200	670	300	210			320	254	21	100
40-125/152	90S	x		65	40	80	113	113		225	178		160	140	103		118	461			225	130				100
40-125/222	90L	x	x	65	40	80	113	113		225	178		160	140	103		118	461			225	130				100
40-125/302	100L	x	x	65	40	80	113	113		225	198		160	140	103		118	508			225	130				100
40-125/402	112M	x	x	65	40	80	113	113		225	222		160	140	103		118	530			225	130				100
40-125/552	132S	x	x	65	40	80	113	113	43	225	265	12		140	103	132	193	557	220	140			270	216	15	100
40-125/752	132S	x	x	65	40	80	113	113	43	225	265	12		140	103	132	193	557	220	140			270	216	15	100
40-125/1102	160M		x	65	40	80	113	113	70	225	323	14		140	103	160	200	650	300	210			320	254	21	100
40-160/302	100L	x		65	40	80	115	131		225	198		160	160	118		118	508			225	130				100
40-160/402	112M	x	x	65	40	80	115	131		225	222		160	160	118		118	530			225	130				100
40-160/552	132S	x	x	65	40	80	115	131	43	225	265	12		160	118	132	193	557	220	140			270	216	15	100
40-160/752	132S	x	x	65	40	80	115	131	43	225	265	12		160	118	132	193	557	220	140			270	216	15	100
40-160/1102	160M	x	x	65	40	80	115	131	70	225	323	14		160	118	160	200	650	300	210			320	254	21	100
40-160/1502	160M		x	65	40	80	115	131	70	225	323	14		160	118	160	200	650	300	210			320	254	21	100
40-200/552 ⁴⁾	132S	x		65	40	100	140	152	43	275	265	12		180	140	132	193	577	220	140			270	216	15	100
40-200/752 ⁴⁾	132S	x	x	65	40	100	140	152	43	275	265	12		180	140	132	193	577	220	140			270	216	15	100
40-200/1102	160M	x	x	65	40	100	140	152	70	275	323	14		180	140	160	200	670	300	210			320	254	21	100
40-200/1502	160M	x	x	65	40	100	140	152	70	275	323	14		180	140	160	200	670	300	210			320	254	21	100
40-200/1852	160L		x	65	40	100	140	152	70	275	323	14		180	140	160	200	670	314	254			320	254	21	100
40-200/2202	180M		x	65	40	100	140	152	80	275	355	14		180	140	180	214	670	320	241			360	279	23	100
40-250/1102 ⁴⁾	160M	x		65	40	100	165	178	70	320	323	14		225	168	160	200	670	300	210			320	254	21	100
40-250/1502 ⁴⁾	160M	x		65	40	100	165	178	70	320	323	14		225	168	160	200	670	300	210			320	254	21	100
40-250/1852 ⁴⁾	160L	x		65	40	100	165	178	70	320	323	14		225	168	160	200	670	314	254			320	254	21	100
40-250/2202	180M	x		65	40	100	165	178	80	320	355	14		225	168	180	214	670	320	241			360	279	23	100
50-125/302	100L	x		65	50	100	113	128		225	198		160	160	112		118	528			225	130				100
50-125/402	112M	x		65	50	100	113	128		225	222		160	160	112		118	550			225	130				100
50-125/552	132S	x	x	65	50	100	113	128	43	225	265	12		160	112	132	193	577	220	140			270	216	15	100
50-125/752	132S	x	x	65	50	100	113	128	43	225	265	12		160	112	132	193	577	220	140			270	216	15	100
50-125/1102	160M	x	x	65	50	100	113	128	70	225	323	14		160	112	160	200	670	300	210			320	254	21	100
50-125/1502	160M		x	65	50	100	113	128	70	225	323	14		160	112	160	200	670	300	210			320	254	21	100

1) Rc = ISO 7/1 2) EN 1092-2/DN.../PN 16/21/JL1040/B 3) zweistufig/two stages/2 étages/a due stadi/tweetraps 4) \triangle h₃ ≥ h₄
 G = ISO 228/1

Etabloc G, M 50-160/... bis 80-160/..., n = 2900 1/min, n = 3500 1/min

mit Stützfuß (bis Motorbaugröße 112 = 4 kW)
 mit Motorfuß (ab Motorbaugröße 132 = 5,5 kW)
 with support foot (up to motor size 112 = 4 kW)
 with motor foot (motor size 132 = 5.5 kW and above)
 avec béquille (jusqu'à taille de moteur 112 = 4 kW)

avec pied de moteur (à partir de la taille de moteur 132 = 5,5 kW)
 con piede angolare (fino alla grandezza del motore 112 = 4 kW)
 con piede di fusione (a partire della grandezza del motore 132 = 5,5 kW)
 met voetsteun (tot motorgrootte 112 = 4 kW)
 met motorvoet (vanaf motorgrootte 132 = 5,5 kW)

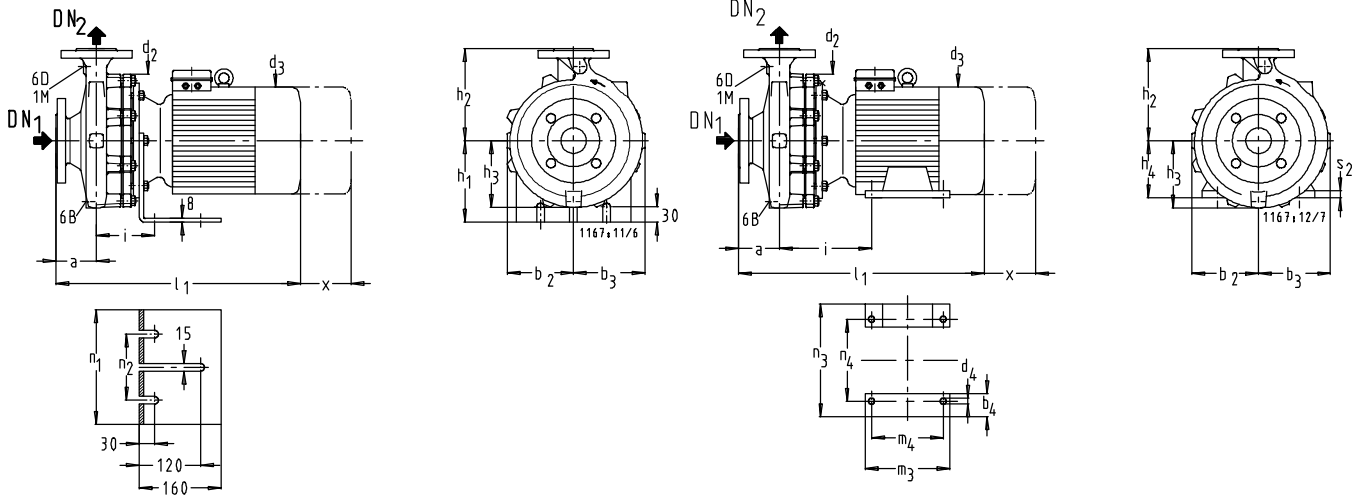

		Etabloc G, M		Etabloc SN, CN	
		Etabloc GN, MN, BN	DN ₂ 32 - DN ₂ 80	DN ₂ 100 - DN ₂ 150	DN ₂ 32 - DN ₂ 80
1 M	Druckmessgerät-Anschluss / Pressure gauge connection / Indicateur de pression / Manomètre / Manometro / Manometer	Rc 3/8 ¹⁾	Rc 1/2 ¹⁾	G 3/8 ¹⁾	G 1/2 ¹⁾
6 B	Förderflüssigkeit-Entleerung / Casing drain / Vidange du liquide pompé / Scarico del liquido convogliato / Vloeistof- aftap	Rc 3/8 ¹⁾	Rc 1/2 ¹⁾	G 3/8 ¹⁾	G 1/2 ¹⁾
6 D	Förderflüssigkeit-Auffüllen und Entlüften / Filling and venting of medium handled / Remplissage et purge d'air du liquide pompé / Riempimento del liquido convogliato spurgo dell'aria / Vloeistof vullen en ontlichten	Rc 3/8 ¹⁾	Rc 1/2 ¹⁾	G 3/8 ¹⁾	G 1/2 ¹⁾

mm

Etabloc G, M	M	n = 2900	n = 3500	Toleranz der Anschlussmaße nach EN 735																						
				DN ₁ 2)	DN ₂ 2)	a	b ₂ ≈	b ₃ ≈	b ₄ ≈	d ₂	d ₃ ≈	d ₄	h ₁	h ₂	h ₃	h ₄	i	l ₁ ≈	m ₃ ≈	m ₄	n ₁	n ₂	n ₃ ≈	n ₄	s ₂	x
50-160/552 ⁴⁾	132S	x	x	65	50	100	126	147	43	225	265	12		180	134	132	193	577	220	140			270	216	15	100
50-160/752 ⁴⁾	132S	x	x	65	50	100	126	147	43	225	265	12		180	134	132	193	577	220	140			270	216	15	100
50-160/1102	160M	x	x	65	50	100	126	147	70	225	323	14		180	134	160	200	670	300	210			320	254	21	100
50-160/1502	160M	x	x	65	50	100	126	147	70	225	323	14		180	134	160	200	670	300	210			320	254	21	100
50-160/1852	160L		x	65	50	100	126	147	70	225	323	14		180	134	160	200	670	314	254			320	254	21	100
50-160/2202	180M	x	x	65	50	100	126	147	80	225	355	14		180	134	180	214	670	320	241			360	279	23	100
50-200/1102	160M	x	x	65	50	100	145	165	70	275	323	14		200	152	160	200	670	300	210			320	254	21	100
50-200/1502	160M	x	x	65	50	100	145	165	70	275	323	14		200	152	160	200	670	300	210			320	254	21	100
50-200/1852	160L	x	x	65	50	100	145	165	70	275	323	14		200	152	160	200	670	314	254			320	254	21	100
50-200/2202	180M	x	x	65	50	100	145	165	80	275	355	14		200	152	180	214	670	320	241			360	279	23	100
50-250/1502 ⁴⁾	160M	x		65	50	100	168	184	70	320	323	14		225	172	160	200	670	300	210			320	254	21	100
50-250/1852 ⁴⁾	160L	x		65	50	100	168	184	70	320	323	14		225	172	160	200	670	314	254			320	254	21	100
50-250/2202	180M	x		65	50	100	168	184	80	320	355	14		225	172	180	214	670	320	241			360	279	23	100
65-125/402	112M	x		80	65	100	120	148		225	222		160	180	132		118	550			225	130				100
65-125/552 ⁴⁾	132S	x	x	80	65	100	120	148	43	225	265	12		180	132	132	193	577	220	140			270	216	15	100
65-125/752 ⁴⁾	132S	x	x	80	65	100	120	148	43	225	265	12		180	132	132	193	577	220	140			270	216	15	100
65-125/1102	160M	x	x	80	65	100	120	148	70	225	323	14		180	132	160	200	670	300	210			320	254	21	100
65-125/1502	160M	x	x	80	65	100	120	148	70	225	323	14		180	132	160	200	670	300	210			320	254	21	100
65-160/752 ⁴⁾	132S	x		80	65	100	130	158	43	225	265	12		200	140	132	193	577	220	140			270	216	15	100
65-160/1102	160M	x	x	80	65	100	130	158	70	225	323	14		200	140	160	200	670	300	210			320	254	21	100
65-160/1502	160M	x	x	80	65	100	130	158	70	225	323	14		200	140	160	200	670	300	210			320	254	21	100
65-160/1852	160L		x	80	65	100	130	158	70	225	323	14		200	140	160	200	670	314	254			320	254	21	100
65-160/2202	180M		x	80	65	100	130	158	80	225	355	14		200	140	180	214	670	320	241			360	279	23	100
65-200/1502 ⁴⁾	160M	x		80	65	100	154	177	70	275	323	14		225	161	160	200	670	300	210			320	254	21	140
65-200/1852 ⁴⁾	160L	x	x	80	65	100	154	177	70	275	323	14		225	161	160	200	670	314	254			320	254	21	140
65-200/2202	180M	x	x	80	65	100	154	177	80	275	355	14		225	161	180	214	670	320	241			360	279	23	140
80-160/1102 ⁴⁾	160M	x		100	80	125	153	192	70	225	323	14		225	168	160	200	695	300	210			320	254	21	140
80-160/1502 ⁴⁾	160M	x		100	80	125	153	192	70	225	323	14		225	168	160	200	695	300	210			320	254	21	140
80-160/1852 ⁴⁾	160L	x		100	80	125	153	192	70	225	323	14		225	168	160	200	695	314	254			320	254	21	140
80-160/2202	180M	x	x	100	80	125	153	192	80	225	355	14		225	168	180	214	695	320	241			360	279	23	140

1) Rc = ISO 7/1; G = ISO 228/1
 2) EN 1092-2/DN.../PN 16/21/JL1040/B
 3) zweistufig/two stages/2 étages/a due stadi/tweetraps
 4) h₃ ≥ h₄

Etabloc G, M 25-20.1/... bis 40-125/..., n = 1450 1/min, n = 1750 1/min

mit Stützfuß (bis Motorbaugröße 112 = 4 kW)
 mit Motorfuß (ab Motorbaugröße 132 = 5,5 kW)
 with support foot (up to motor size 112 = 4 kW)
 with motor foot (motor size 132 = 5.5 kW and above)
 avec béquille (jusqu'à taille de moteur 112 = 4 kW)

avec pied de moteur (à partir de la taille de moteur 132 = 5,5 kW)
 con piede angolare (fino alla grandezza del motore 112 = 4 kW)
 con piede di fusione (a partire della grandezza del motore 132 = 5,5 kW)
 met voetsteun (tot motorgrootte 112 = 4 kW)
 met motorvoet (vanaf motorgrootte 132 = 5,5 kW)

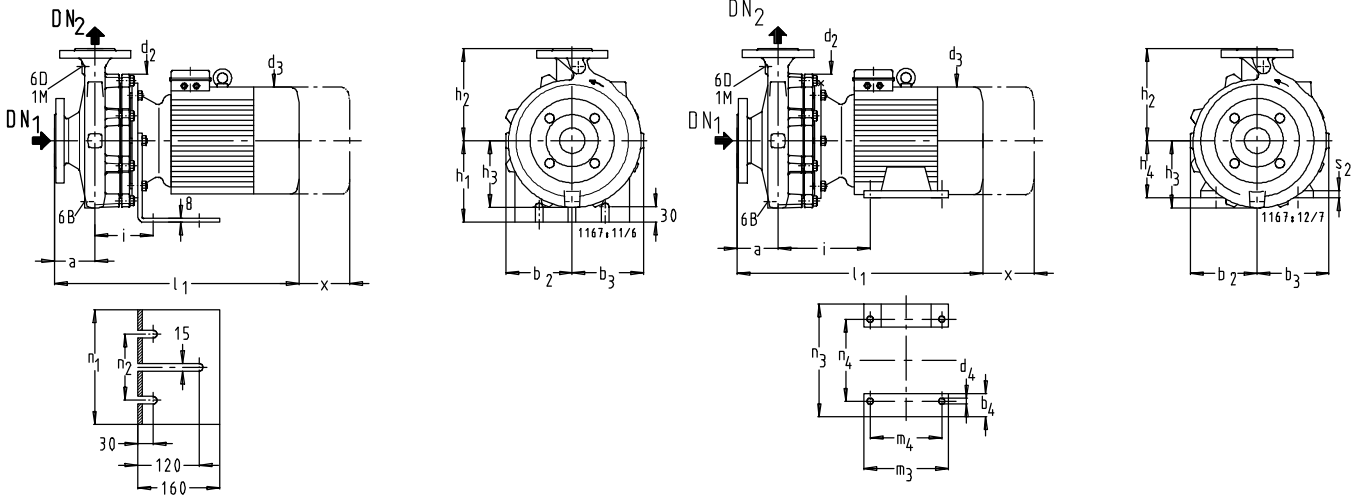

		Etabloc G, M		Etabloc SN, CN	
		Etabloc GN, MN, BN	DN ₂ 32 - DN ₂ 80	DN ₂ 100	DN ₂ 32 - DN ₂ 80
1 M	Druckmessgerät-Anschluss / Pressure gauge connection / Indicateur de pression / Manomètre / Manometro / Manometer	Rc 3/8 ¹⁾	Rc 1/2 ¹⁾	G 3/8 ¹⁾	G 1/2 ¹⁾
6 B	Förderflüssigkeit-Entleerung / Casing drain / Vidange du liquide pompé / Scarico del liquido convogliato / Vloeistof-aftap	Rc 3/8 ¹⁾	Rc 1/2 ¹⁾	G 3/8 ¹⁾	G 1/2 ¹⁾
6 D	Förderflüssigkeit-Auffüllen und Entlüften / Filling and venting of medium handled / Remplissage et purge d'air du liquide pompé / Riempimento del liquido convogliato spurgo dell'aria / Vloeistof vullen en ontluften	Rc 3/8 ¹⁾	Rc 1/2 ¹⁾	G 3/8 ¹⁾	G 1/2 ¹⁾

mm

Etabloc G, M	Ⓜ	n = 1450	n = 1750	Toleranz der Anschlussmaße nach EN 735																						
				DN ₁	DN ₂	a	b ₂ ≈	b ₃ ≈	b ₄ ≈	d ₂	d ₃ ≈	d ₄	h ₁	h ₂	h ₃	h ₄	i	l ₁ ≈	m ₃ ≈	m ₄	n ₁	n ₂	n ₃ ≈	n ₄	s ₂	x
25-20.1/034	71	x		40	25	90	140	140		215	138		150	175	140		105	405			214	130				145
32-125.1/024	71	x	x	50	32	80	113	113		225	143		160	140	103		118	409			225	130				100
32-125.1/034	71	x	x	50	32	80	113	113		225	143		160	140	103		118	409			225	130				100
32-125.1/054	80	x	x	50	32	80	113	113		225	160		160	140	103		118	426			225	130				100
32-160.1/034	71	x	x	50	32	80	116	125		225	143		160	160	115		118	409			225	130				100
32-160.1/054	80	x	x	50	32	80	116	125		225	160		160	160	115		118	426			225	130				100
32-160.1/074	80	x	x	50	32	80	116	125		225	160		160	160	115		118	426			225	130				100
32-160.1/114	90S		x	50	32	80	116	125		225	178		160	160	115		118	461			225	130				100
32-200.1/054	80	x	x	50	32	80	128	137		275	160		160	180	130		118	426			225	130				100
32-200.1/074	80	x	x	50	32	80	128	137		275	160		160	180	130		118	426			225	130				100
32-200.1/114	90S		x	50	32	80	128	137		275	178		160	180	130		118	461			225	130				100
32-200.1/154	90L		x	50	32	80	128	137		275	178		160	180	130		118	461			225	130				100
32-200.1/224	100L		x	50	32	80	128	137		275	198		160	180	130		118	508			225	130				100
32-250.1/074 ³⁾	80	x		50	32	100	164	171		320	160		160	225	162		118	446			225	130				100
32-250.1/114 ³⁾	90S	x	x	50	32	100	164	171		320	178		160	225	162		118	481			225	130				100
32-250.1/154 ³⁾	90L	x	x	50	32	100	164	171		320	178		160	225	162		118	481			225	130				100
32-250.1/224 ³⁾	100L		x	50	32	100	164	171		320	198		160	225	162		118	528			225	130				100
32-250.1/304 ³⁾	100L		x	50	32	100	164	171		320	198		160	225	162		118	528			225	130				100
32-125/034	71	x	x	50	32	80	113	113		225	143		160	140	103		118	409			225	130				100
32-125/054	80	x	x	50	32	80	113	113		225	160		160	140	103		118	426			225	130				100
32-125/074	80		x	50	32	80	113	113		225	160		160	140	103		118	426			225	130				100
32-160/054	80	x	x	50	32	80	113	125		225	160		160	160	115		118	426			225	130				100
32-160/074	80		x	50	32	80	113	125		225	160		160	160	115		118	426			225	130				100
32-160/114	90S		x	50	32	80	113	125		225	178		160	160	115		118	461			225	130				100
32-200/054	80	x		50	32	80	132	141		275	160		160	180	133		118	426			225	130				100
32-200/074	80	x	x	50	32	80	132	141		275	160		160	180	133		118	426			225	130				100
32-200/114	90S	x	x	50	32	80	132	141		275	178		160	180	133		118	461			225	130				100
32-200/154	90L		x	50	32	80	132	141		275	178		160	180	133		118	461			225	130				100
32-200/224	100L		x	50	32	80	132	141		275	198		160	180	133		118	508			225	130				100
32-250/114 ³⁾	90S	x		50	32	100	170	176		320	178		160	225	168		118	481			225	130				100
32-250/154 ³⁾	90L	x		50	32	100	170	176		320	178		160	225	168		118	481			225	130				100
32-250/224 ³⁾	100L	x	x	50	32	100	170	176		320	198		160	225	168		118	528			225	130				100
32-250/304 ³⁾	100L		x	50	32	100	170	176		320	198		160	225	168		118	528			225	130				100
32-250/404 ³⁾	112M		x	50	32	100	170	176		320	222		160	225	168		118	550			225	130				100
40-125/024	71	x		65	40	80	113	113		225	143		160	140	103		118	409			225	130				100
40-125/034	71	x		65	40	80	113	113		225	143		160	140	103		118	409			225	130				100
40-125/054	80	x	x	65	40	80	113	113		225	160		160	140	103		118	426			225	130				100
40-125/074	80		x	65	40	80	113	113		225	160		160	140	103		118	426			225	130				100
40-125/114	90S		x	65	40	80	113	113		225	178		160	140	103		118	461			225	130				100

1) Rc = ISO 7/1; G = ISO 228/1
 2) ≤ DN 150 = EN 1092-2/DN.../PN 16/21/JL1040/B
 DN 200 = EN 1092-2/DN 200/PN 10/21/JL1040/B

3) Δ h₃ ≥ h₁ / h₃ ≥ h₄

Etabloc G, M 40-160/... bis 50-250/..., n = 1450 1/min, n = 1750 1/min

mit Stützfuß (bis Motorbaugröße 112 = 4 kW)
 mit Motorfuß (ab Motorbaugröße 132 = 5,5 kW)
 with support foot (up to motor size 112 = 4 kW)
 with motor foot (motor size 132 = 5.5 kW and above)
 avec béquille (jusqu'à taille de moteur 112 = 4 kW)

avec pied de moteur (à partir de la taille de moteur 132 = 5,5 kW)
 con piede angolare (fino alla grandezza del motore 112 = 4 kW)
 con piede di fusione (a partire della grandezza del motore 132 = 5,5 kW)
 met voetsteun (tot motorgrootte 112 = 4 kW)
 met motorvoet (vanaf motorgrootte 132 = 5,5 kW)

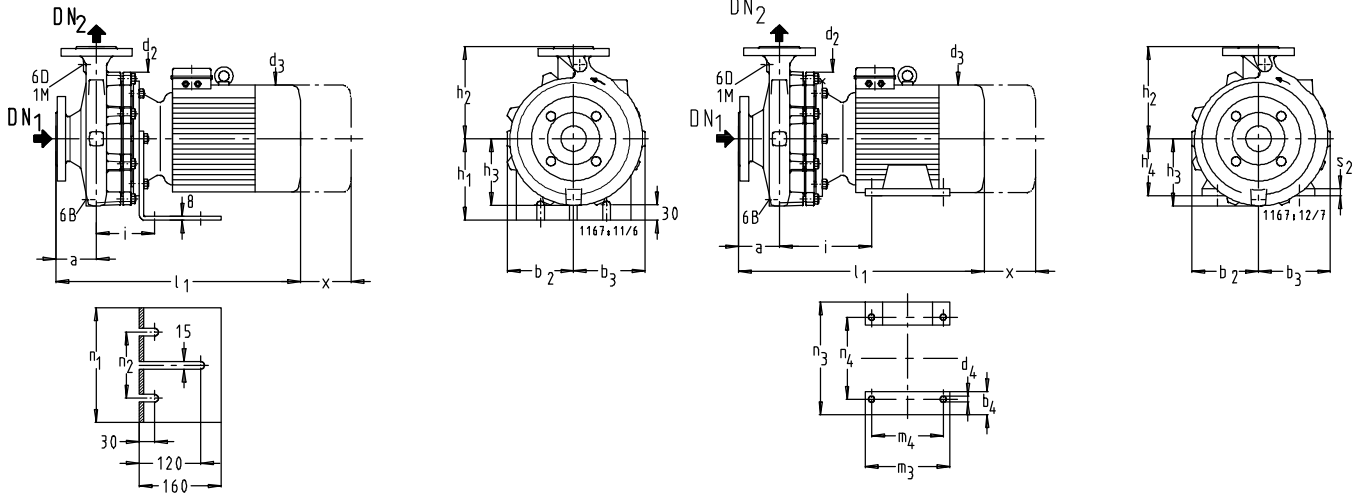

		Etabloc G, M		Etabloc SN, CN	
		Etabloc GN, MN, BN		DN ₂ 32 - DN ₂ 80	DN ₂ 100 - DN ₂ 150
1 M	Druckmessgerät-Anschluss / Pressure gauge connection / Indicateur de pression / Manomètre / Manometro / Manometer	Rc 3/8 ¹⁾	Rc 1/2 ¹⁾	G 3/8 ¹⁾	G 1/2 ¹⁾
6 B	Förderflüssigkeit-Entleerung / Casing drain / Vidange du liquide pompé / Scarico del liquido convogliato / Vloeistof- aftap	Rc 3/8 ¹⁾	Rc 1/2 ¹⁾	G 3/8 ¹⁾	G 1/2 ¹⁾
6 D	Förderflüssigkeit-Auffüllen und Entlüften / Filling and venting of medium handled / Remplissage et purge d'air du liquide pompé / Riempimento del liquido convogliato spurgo dell'aria / Vloeistof vullen en ontlichten	Rc 3/8 ¹⁾	Rc 1/2 ¹⁾	G 3/8 ¹⁾	G 1/2 ¹⁾

mm

Etabloc G, M	Ⓜ	n = 1450	n = 1750	Toleranz der Anschlussmaße nach EN 735																							
				DN ₁ 2)	DN ₂ 2)	a	b ₂ ≈	b ₃ ≈	b ₄ ≈	d ₂	d ₃ ≈	d ₄	h ₁	h ₂	h ₃	h ₄	i	l ₁ ≈	m ₃ ≈	m ₄	n ₁	n ₂	n ₃ ≈	n ₄	s ₂	x	
40-160/054	80	x		65	40	80	115	131		225	160		160	160	118		118	426			225	130					100
40-160/074	80	x	x	65	40	80	115	131		225	160		160	160	118		118	426			225	130					100
40-160/114	90S	x	x	65	40	80	115	131		225	178		160	160	118		118	461			225	130					100
40-160/154	90L		x	65	40	80	115	131		225	178		160	160	118		118	461			225	130					100
40-160/224	100L		x	65	40	80	115	131		225	198		160	160	118		118	508			225	130					100
40-200/074	80	x		65	40	100	140	152		275	160		160	180	140		118	446			225	130					100
40-200/114	90S	x		65	40	100	140	152		275	178		160	180	140		118	481			225	130					100
40-200/154	90L	x	x	65	40	100	140	152		275	178		160	180	140		118	481			225	130					100
40-200/224	100L		x	65	40	100	140	152		275	198		160	180	140		118	528			225	130					100
40-200/304	100L		x	65	40	100	140	152		275	198		160	180	140		118	528			225	130					100
40-250/114 ³⁾	90S	x		65	40	100	165	178		320	178		160	225	168		118	481			225	130					100
40-250/154 ³⁾	90L	x		65	40	100	165	178		320	178		160	225	168		118	481			225	130					100
40-250/224 ³⁾	100L	x	x	65	40	100	165	178		320	198		160	225	168		118	528			225	130					100
40-250/304 ³⁾	100L	x	x	65	40	100	165	178		320	198		160	225	168		118	528			225	130					100
40-250/404 ³⁾	112M		x	65	40	100	165	178		320	222		160	225	168		118	550			225	130					100
40-315/224 ³⁾	100L	x		65	40	125	194	203		400	198		180	250	196		142	576			260	180					100
40-315/304 ³⁾	100L	x		65	40	125	194	203		400	198		180	250	196		142	576			260	180					100
40-315/404 ³⁾	112M	x	x	65	40	125	194	203		400	222		180	250	196		142	597			260	180					100
40-315/554 ³⁾	132S	x	x	65	40	125	194	203	43	400	265	12		250	196	132	216	625	220	140				270	216	15	100
40-315/754 ³⁾	132M		x	65	40	125	194	203	43	400	265	12		250	196	132	216	625	240	178				270	216	15	100
40-315/31104 ³⁾	160M		x	65	40	125	194	203	70	400	323	14		250	196	160	223	718	300	210				320	254	21	100
50-125/054	80	x		65	50	100	113	128		225	160		160	160	112		118	446			225	130					100
50-125/074	80	x	x	65	50	100	113	128		225	160		160	160	112		118	446			225	130					100
50-125/114	90S	x	x	65	50	100	113	128		225	178		160	160	112		118	481			225	130					100
50-125/154	90L		x	65	50	100	113	128		225	178		160	160	112		118	481			225	130					100
50-160/074	80	x		65	50	100	126	147		225	160		160	180	134		118	446			225	130					100
50-160/114	90S	x	x	65	50	100	126	147		225	178		160	180	134		118	481			225	130					100
50-160/154	90L	x	x	65	50	100	126	147		225	178		160	180	134		118	481			225	130					100
50-160/224	100L		x	65	50	100	126	147		225	198		160	180	134		118	528			225	130					100
50-160/304	100L		x	65	50	100	126	147		225	198		160	180	134		118	528			225	130					100
50-200/154	90L	x		65	50	100	145	165		275	178		160	200	152		118	481			225	130					100
50-200/224	100L	x	x	65	50	100	145	165		275	198		160	200	152		118	528			225	130					100
50-200/304	100L	x	x	65	50	100	145	165		275	198		160	200	152		118	528			225	130					100
50-200/404	112M		x	65	50	100	145	165		275	222		160	200	152		118	550			225	130					100
50-250/224 ³⁾	100L	x	x	65	50	100	168	184		320	198		160	225	172		118	528			225	130					100
50-250/304 ³⁾	100L	x		65	50	100	168	184		320	198		160	225	172		118	528			225	130					100
50-250/404 ³⁾	112M	x	x	65	50	100	168	184		320	222		160	225	172		118	550			225	130					100

1) Rc = ISO 7/1; G = ISO 228/1
 2) ≤ DN 150 = EN 1092-2/DN../PN 16/21/JL1040/B
 DN 200 = EN 1092-2/DN 200/PN 10/21/JL1040/B

3) Δ h₃ ≥ h₁ / h₃ ≥ h₄

Etabloc G, M 50-315/... bis 80-200/..., n = 1450 1/min, n = 1750 1/min

mit Stützfuß (bis Motorbaugröße 112 = 4 kW)
 mit Motorfuß (ab Motorbaugröße 132 = 5,5 kW)
 with support foot (up to motor size 112 = 4 kW)
 with motor foot (motor size 132 = 5.5 kW and above)
 avec béquille (jusqu'à taille de moteur 112 = 4 kW)

avec pied de moteur (à partir de la taille de moteur 132 = 5,5 kW)
 con piede angolare (fino alla grandezza del motore 112 = 4 kW)
 con piede di fusione (a partire della grandezza del motore 132 = 5,5 kW)
 met voetsteen (tot motorgrootte 112 = 4 kW)
 met motorvoet (vanaf motorgrootte 132 = 5,5 kW)

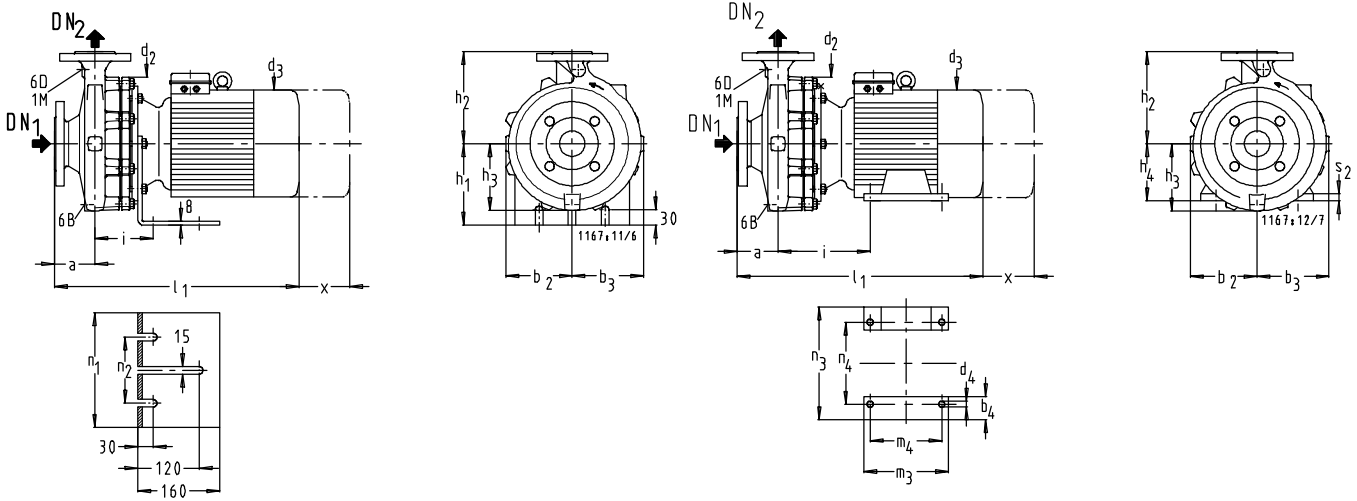

		Etabloc G, M		Etabloc SN, CN	
		Etabloc GN, MN, BN		DN ₂ 32 - DN ₂ 80	DN ₂ 100 - DN ₂ 150
1 M	Druckmessgerät-Anschluss / Pressure gauge connection / Indicateur de pression / Manomètre / Manometro / Manometer	Rc 3/8 ¹⁾	Rc 1/2 ¹⁾	G 3/8 ¹⁾	G 1/2 ¹⁾
6 B	Förderflüssigkeit-Entleerung / Casing drain / Vidange du liquide pompé / Scarico del liquido convogliato / Vloeistof- aftap	Rc 3/8 ¹⁾	Rc 1/2 ¹⁾	G 3/8 ¹⁾	G 1/2 ¹⁾
6 D	Förderflüssigkeit-Auffüllen und Entlüften / Filling and venting of medium handled / Remplissage et purge d'air du liquide pompé / Riempimento del liquido convogliato spurgo dell'aria / Vloeistof vullen en ontluchten	Rc 3/8 ¹⁾	Rc 1/2 ¹⁾	G 3/8 ¹⁾	G 1/2 ¹⁾

Etabloc G, M	M	n = 1450	n = 1750	Toleranz der Anschlussmaße nach EN 735																		mm					
				DN ₁ ²⁾	DN ₂ ²⁾	a	b ₂ ≈	b ₃ ≈	b ₄ ≈	d ₂	d ₃ ≈	d ₄	h ₁	h ₂	h ₃	h ₄	i	l ₁ ≈	m ₃ ≈	m ₄	n ₁		n ₂	n ₃ ≈	n ₄	s ₂	x
50-315/304 ³⁾	100L	x		65	50	125	200	216		400	198		180	280	204		142	576			260	180					100
50-315/404 ³⁾	112M	x		65	50	125	200	216		400	222		180	280	204		142	597			260	180					100
50-315/554 ³⁾	132S	x	x	65	50	125	200	216	43	400	265	12		280	204	132	216	625	220	140							100
50-315/754 ³⁾	132M	x	x	65	50	125	200	216	43	400	265	12		280	204	132	216	625	240	178							100
50-315/1104 ³⁾	160M	x	x	65	50	125	200	216	70	400	323	14		280	204	160	223	718	300	210							100
50-315/1504 ³⁾	160L		x	65	50	125	200	216	70	400	323	14		280	204	160	223	718	314	254							100
65-125/054	80	x		80	65	100	120	148		225	160		160	180	132		118	446			225	130					100
65-125/074	80	x	x	80	65	100	120	148		225	160		160	180	132		118	446			225	130					100
65-125/114	90S	x	x	80	65	100	120	148		225	178		160	180	132		118	481			225	130					100
65-125/154	90L	x	x	80	65	100	120	148		225	178		160	180	132		118	481			225	130					100
65-125/224	100L		x	80	65	100	120	148		225	198		160	180	132		118	528			225	130					100
65-160/114	90S	x		80	65	100	130	158		225	178		160	200	140		118	481			225	130					100
65-160/154	90L	x	x	80	65	100	130	158		225	178		160	200	140		118	481			225	130					100
65-160/224	100L	x	x	80	65	100	130	158		225	198		160	200	140		118	528			225	130					100
65-160/304	100L		x	80	65	100	130	158		225	198		160	200	140		118	528			225	130					100
65-160/404	112M		x	80	65	100	130	158		225	222		160	200	140		118	550			225	130					100
65-200/224 ³⁾	100L	x		80	65	100	154	177		275	198		160	225	161		118	528			225	130					140
65-200/304 ³⁾	100L	x		80	65	100	154	177		275	198		160	225	161		118	528			225	130					140
65-200/404 ³⁾	112M	x	x	80	65	100	154	177		275	222		160	225	161		118	550			225	130					140
65-250/304 ³⁾	100L	x		80	65	100	180	200		320	198		180	250	186		142	551			260	180					140
65-250/404 ³⁾	112M	x		80	65	100	180	200		320	222		180	250	186		142	572			260	180					140
65-250/554 ³⁾	132S	x	x	80	65	100	180	200	43	320	265	12		250	186	132	216	600	220	140							140
65-250/754 ³⁾	132M	x	x	80	65	100	180	200	43	320	265	12		250	186	132	216	600	240	178							140
65-250/1104 ³⁾	160M	x	x	80	65	100	180	200	70	320	323	14		250	186	160	223	693	300	210							140
65-315/554 ³⁾	132S	x		80	65	125	208	229	43	400	265	12		280	214	132	216	625	220	140							140
65-315/754 ³⁾	132M	x		80	65	125	208	229	43	400	265	12		280	214	132	216	625	240	178							140
65-315/1104 ³⁾	160M	x	x	80	65	125	208	229	70	400	323	14		280	214	160	223	718	300	210							140
65-315/1504 ³⁾	160L	x	x	80	65	125	208	229	70	400	323	14		280	214	160	223	718	314	254							140
65-315/1854 ³⁾	180M		x	80	65	125	208	229	80	400	360	14		280	214	180	237	782	320	241							140
65-315/2204 ³⁾	180L		x	80	65	125	208	229	80	400	360	14		280	214	180	237	819	358	279							140
80-160/154 ³⁾	90L	x		100	80	125	153	192		225	178		160	225	168		118	506			225	130					140
80-160/224 ³⁾	100L	x		100	80	125	153	192		225	198		160	225	168		118	553			225	130					140
80-160/304 ³⁾	100L	x		100	80	125	153	192		225	198		160	225	168		118	553			225	130					140
80-160/404 ³⁾	112M	x	x	100	80	125	153	192		225	222		160	225	168		118	575			225	130					140
80-200/224	100L	x		100	80	125	161	189		275	198		180	250	170		142	576			260	180					140
80-200/304	100L	x		100	80	125	161	189		275	198		180	250	170		142	576			260	180					140
80-200/404	112M	x		100	80	125	161	189		275	222		180	250	170		142	597			260	180					140
80-200/554 ³⁾	132S	x	x	100	80	125	161	189	43	275	265	12		250	170	132	216	625	220	140							140
80-200/754 ³⁾	132M	x	x	100	80	125	161	189	43	275	265	12		250	170	132	216	625	240	178							140
80-200/1104 ³⁾	160M	x		100	80	125	161	189	70	275	323	14		250	170	160	223	718	300	210							140

1) Rc = ISO 7/1; 2) ≤ DN 150 = EN 1092-2/DN.../PN 16/21/JL1040/B; 3) Δ h₃ ≥ h₁ / h₃ ≥ h₄
 G = ISO 228/1; DN 200 = EN 1092-2/DN 200/PN 10/21/JL1040/B

Etabloc G, M 80-250/... bis 150-250/..., n = 1450 1/min, n = 1750 1/min

mit Stützfuß (bis Motorbaugröße 112 = 4 kW)
 mit Motorfuß (ab Motorbaugröße 132 = 5,5 kW)
 with support foot (up to motor size 112 = 4 kW)
 with motor foot (motor size 132 = 5.5 kW and above)
 avec béquille (jusqu'à taille de moteur 112 = 4 kW)

avec pied de moteur (à partir de la taille de moteur 132 = 5,5 kW)
 con piede angolare (fino alla grandezza del motore 112 = 4 kW)
 con piede di fusione (a partire della grandezza del motore 132 = 5,5 kW)
 met voetsteun (tot motorgroote 112 = 4 kW)
 met motorvoet (vanaf motorgroote 132 = 5,5 kW)

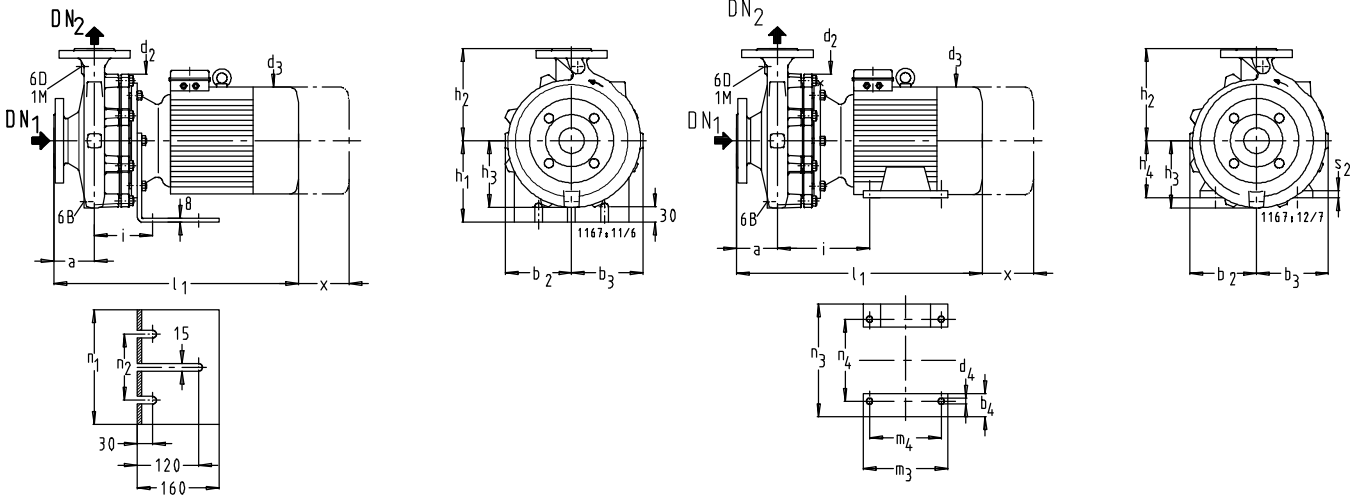

		Etabloc G, M		Etabloc SN, CN	
		Etabloc GN, MN, BN	DN ₂ 100	DN ₂ 32 - DN ₂ 80	DN ₂ 100 - DN ₂ 150
1 M	Druckmessgerät-Anschluss / Pressure gauge connection / Indicateur de pression / Manomètre / Manometro / Manometer	Rc 3/8 ¹⁾	Rc 1/2 ¹⁾	G 3/8 ¹⁾	G 1/2 ¹⁾
6 B	Förderflüssigkeit-Entleerung / Casing drain / Vidange du liquide pompé / Scarico del liquido convogliato / Vloeistof- aftap	Rc 3/8 ¹⁾	Rc 1/2 ¹⁾	G 3/8 ¹⁾	G 1/2 ¹⁾
6 D	Förderflüssigkeit-Auffüllen und Entlüften / Filling and venting of medium handled / Rempissage et purge d'air du liquide pompé / Riempimento del liquido convogliato spurgo dell'aria / Vloeistof vullen en ontluchten	Rc 3/8 ¹⁾	Rc 1/2 ¹⁾	G 3/8 ¹⁾	G 1/2 ¹⁾

mm

Etabloc G, M	M	n = 1450	n = 1750	Toleranz der Anschlussmaße nach EN 735																							
				DN ₁ 2)	DN ₂ 2)	a	b ₂ =	b ₃ =	b ₄ =	d ₂	d ₃ ≈	d ₄	h ₁	h ₂	h ₃	h ₄	i	l ₁ =	m ₃ =	m ₄	n ₁	n ₂	n ₃ =	n ₄	s ₂	x	
80-250/404 ³⁾	112M	x		100	80	125	184	210		320	222		180	280	195	132	142	597			260	180					140
80-250/554 ³⁾	132S	x		100	80	125	184	210	43	320	265	12		280	195	132	216	625	220	140				270	216	15	140
80-250/754 ³⁾	132M	x	x	100	80	125	184	210	43	320	265	12		280	195	132	216	625	240	178				270	216	15	140
80-250/1104 ³⁾	160M	x	x	100	80	125	184	210	70	320	323	14		280	195	160	223	718	300	210				320	254	21	140
80-250/1504 ³⁾	160L	x	x	100	80	125	184	210	70	320	323	14		280	195	160	223	718	314	254				320	254	21	140
80-250/1854 ³⁾	180M	x	x	100	80	125	184	210	80	320	360	14		280	195	180	237	782	320	241				360	279	23	140
80-315/754 ³⁾	132M	x		100	80	125	220	244	43	400	265	12		315	228	132	216	625	240	178				270	216	15	140
80-315/1104 ³⁾	160M	x		100	80	125	220	244	70	400	323	14		315	228	160	223	718	300	210				320	254	21	140
80-315/1504 ³⁾	160L	x	x	100	80	125	220	244	70	400	323	14		315	228	160	223	718	314	254				320	254	21	140
80-315/1854 ³⁾	180M	x	x	100	80	125	220	244	80	400	360	14		315	228	180	237	782	320	241				360	279	23	140
80-315/2204 ⁴⁾	180L	x	x	100	80	125	220	244	80	400	360	14		315	228	180	237	819	358	279				360	279	23	140
100-160/304 ³⁾	100L	x		125	100	125	178	225		275	198		180	280	196		142	576			260	180				140	
100-160/404 ³⁾	112M	x		125	100	125	178	225		275	222		180	280	196		142	597			260	180				140	
100-160/554 ³⁾	132S	x	x	125	100	125	178	225	43	275	265	12		280	196	132	216	625	220	140				270	216	15	140
100-160/754 ³⁾	132M	x	x	125	100	125	178	225	43	275	265	12		280	196	132	216	625	240	178				270	216	15	140
100-200/404 ³⁾	112M	x		125	100	125	173	213		275	222		180	280	190		142	597			260	180				140	
100-200/554 ³⁾	132S	x		125	100	125	173	213	43	275	265	12		280	190	132	216	625	220	140				270	216	15	140
100-200/754 ³⁾	132M	x	x	125	100	125	173	213	43	275	265	12		280	190	132	216	625	240	178				270	216	15	140
100-200/1104 ³⁾	160M	x	x	125	100	125	173	213	70	275	323	14		280	190	160	223	718	300	210				320	254	21	140
100-200/1504 ³⁾	160L	x	x	125	100	125	173	213	70	275	323	14		280	190	160	223	718	314	254				320	254	21	140
100-250/754 ³⁾	132M	x		125	100	140	190	220	43	320	265	12		280	201	132	216	640	240	178				270	216	15	140
100-250/1104 ³⁾	160M	x	x	125	100	140	190	220	70	320	323	14		280	201	160	223	733	300	210				320	254	21	140
100-250/1504 ³⁾	160L	x	x	125	100	140	190	220	70	320	323	14		280	201	160	223	733	314	254				320	254	21	140
100-250/1854 ³⁾	180M	x	x	125	100	140	190	220	80	320	360	14		280	201	180	237	797	320	241				360	279	23	140
100-250/2204 ³⁾	180L	x	x	125	100	140	190	220	80	320	360	14		280	201	180	237	834	358	279				360	279	23	140
100-315/1504 ³⁾	160L	x		125	100	140	225	255	70	400	323	14		315	237	160	223	733	314	254				320	254	21	140
100-315/1854 ³⁾	180M	x	x	125	100	140	225	255	80	400	360	14		315	237	180	237	797	320	241				360	279	23	140
100-315/2204 ³⁾	180L	x	x	125	100	140	225	255	80	400	360	14		315	237	180	237	834	358	279				360	279	23	140
125-200/754 ³⁾	132M	x		150	125	140	195	244	43	275	265	12		315	216	132	216	640	240	178				270	216	15	140
125-200/1104 ³⁾	160M	x	x	150	125	140	195	244	70	275	323	14		315	216	160	223	733	300	210				320	254	21	140
125-200/1504 ³⁾	160L	x	x	150	125	140	195	244	70	275	323	14		315	216	160	223	733	314	254				320	254	21	140
125-200/1854 ³⁾	180M	x	x	150	125	140	195	244	80	275	360	14		315	216	180	237	797	320	241				360	279	23	140
125-200/2204 ³⁾	180L	x	x	150	125	140	195	244	80	275	360	14		315	216	180	237	834	358	279				360	279	23	140
125-250/1104 ³⁾	160M	x		150	125	140	226	275	70	320	323	14		315	245	160	223	733	300	210				320	254	21	140
125-250/1504 ³⁾	160L	x	x	150	125	140	226	275	70	320	323	14		315	245	160	223	733	314	254				320	254	21	140
125-250/1854 ³⁾	180M	x	x	150	125	140	226	275	80	320	360	14		315	245	180	237	797	320	241				360	279	23	140
125-250/2204 ³⁾	180L	x	x	150	125	140	226	275	80	320	360	14		315	245	180	237	834	358	279				360	279	23	140
150-200/754 ³⁾	132M	x		200	150	160	238	315	43	275	265	12		400	275	132	216	660	240	178				270	216	15	140
150-200/1104 ³⁾	160M	x		200	150	160	238	315	70	275	323	14		400	275	160	223	753	300	210				320	254	21	140
150-200/1504 ³⁾	160L	x	x	200	150	160	238	315	70	275	323	14		400	275	160	223	753	314	254				320	254	21	140
150-200/1854 ³⁾	180M	x	x	200	150	160	238	315	80	275	360	14		400	275	180	237	817	320	241				360	279	23	140
150-200/2204 ³⁾	180L	x	x	200	150	160	238	315	80	275	360	14		400	275	180	237	854	358	279				360	279	23	140
150-250/1504 ³⁾	160L	x		200	150	160	228	298	70	320	323	14		400	260	160	223	753	314	254				320	254	21	140
150-250/1854 ³⁾	180M	x		200	150	160	228	298	80	320	360	14		400	260	180	237	817	320	241				360	279	23	140
150-250/2204 ³⁾	180L	x	x	200	150	160	228	298	80	320	360	14		400	260	180	237	854	358	279				360	279	23	140

1) Rc = ISO 7/1; G = ISO 228/1
 2) ≤ DN 150 = EN 1092-2/DN.../PN 16/21/JL1040/B
 DN 200 = EN 1092-2/DN 200/PN 10/21/JL1040/B

3) $h_3 \geq h_1 / h_3 \geq h_4$

Etabloc GN, MN 32-125.1/... bis 32-250/..., n = 2900 1/min, n = 3500 1/min

mit Stützfuß (bis Motorbaugröße 112 = 4 kW)
 mit Motorfuß (ab Motorbaugröße 132 = 5,5 kW)
 with support foot (up to motor size 112 = 4 kW)
 with motor foot (motor size 132 = 5.5 kW and above)
 avec béquille (jusqu'à taille de moteur 112 = 4 kW)

avec pied de moteur (à partir de la taille de moteur 132 = 5,5 kW)
 con piede angolare (fino alla grandezza del motore 112 = 4 kW)
 con piede di fusione (a partire della grandezza del motore 132 = 5,5 kW)
 met voetsteun (tot motorgrootte 112 = 4 kW)
 met motorvoet (vanaf motorgrootte 132 = 5,5 kW)

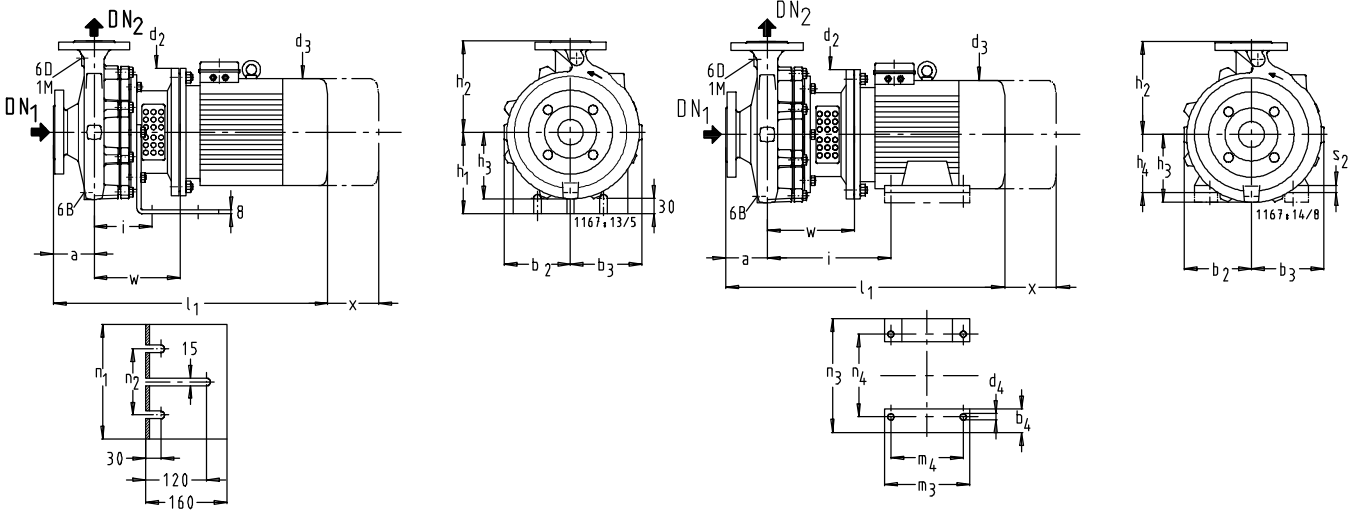

		Etabloc G, M Etabloc GN, MN, BN		Etabloc SN, CN	
		DN ₂ 32 - DN ₂ 80	DN ₂ 100	DN ₂ 32 - DN ₂ 80	DN ₂ 100 - DN ₂ 150
1 M	Druckmessgerät-Anschluss / Pressure gauge connection / Indicateur de pression / Manomètre / Manometro / Manometer	Rc 3/8 ¹⁾	Rc 1/2 ¹⁾	G 3/8 ¹⁾	G 1/2 ¹⁾
6 B	Förderflüssigkeit-Entleerung / Casing drain / Vidange du liquide pompé / Scarico del liquido convogliato / Vloeistof- aftap	Rc 3/8 ¹⁾	Rc 1/2 ¹⁾	G 3/8 ¹⁾	G 1/2 ¹⁾
6 D	Förderflüssigkeit-Auffüllen und Entlüften / Filling and venting of medium handled / Riemplissage et purge d'air du liquide pompé / Riempimento del liquido convogliato spurgo dell'aria / Vloeistof vullen en ontluichten	Rc 3/8 ¹⁾	Rc 1/2 ¹⁾	G 3/8 ¹⁾	G 1/2 ¹⁾

mm

Etabloc GN, MN	M	n = 2900	n = 3500	Toleranz der Anschlussmaße nach EN 735																								
				DN ₁ (2)	DN ₂ (2)	a	b ₂ ≈	b ₃ ≈	b ₄ ≈	d ₂	d ₃ ≈	d ₄	h ₁	h ₂	h ₃	h ₄	i	l ₁ ≈	m ₃ ≈	m ₄	n ₁	n ₂	n ₃ ≈	n ₄	s ₂	w	x	
32-125.1/072	80	x		50	32	80	113	113		200	162	160	140	103		118	491				225	130					156	100
32-125.1/112	80	x	x	50	32	80	113	113		200	162	160	140	103		118	505				225	130					156	100
32-125.1/152	90S	x	x	50	32	80	113	113		200	190	160	140	103		118	518				225	130					156	100
32-125.1/222	90L	x	x	50	32	80	113	113		200	190	160	140	103		118	544				225	130					156	100
32-125.1/302	100L	x	x	50	32	80	113	113		250	213	160	140	103		118	597				225	130					170	100
32-125.1/402	112M	x	x	50	32	80	113	113		250	234	160	140	103		118	621				225	130					170	100
32-125.1/552 ³⁾	132S	x	x	50	32	80	113	113	55	300	266	12	140	103	132	282	686	220	140				270	216	15	193	100	
32-160.1/152	90S	x		50	32	80	116	125		200	190	160	160	115		118	518				225	130					156	100
32-160.1/222	90L	x	x	50	32	80	116	125		200	190	160	160	115		118	544				225	130					156	100
32-160.1/302	100L	x	x	50	32	80	116	125		250	213	160	160	115		118	597				225	130					170	100
32-160.1/402	112M	x	x	50	32	80	116	125		250	234	160	160	115		118	621				225	130					170	100
32-160.1/552 ³⁾	132S	x	x	50	32	80	116	125	55	300	266	12	160	115	132	282	686	220	140				270	216	15	193	100	
32-160.1/752 ³⁾	132S	x	x	50	32	80	116	125	55	300	266	12	160	115	132	282	686	220	140				270	216	15	193	100	
32-200.1/302	100L	x		50	32	80	128	137		250	213	160	180	130		118	597				225	130					170	100
32-200.1/402	112M	x	x	50	32	80	128	137		250	234	160	180	130		118	621				225	130					170	100
32-200.1/552 ³⁾	132S	x	x	50	32	80	128	137	55	300	266	12	180	130	132	282	686	220	140				270	216	15	193	100	
32-200.1/752 ³⁾	132S	x	x	50	32	80	128	137	55	300	266	12	180	130	132	282	686	220	140				270	216	15	193	100	
32-200.1/1102 ³⁾	160M	x		50	32	80	128	137	70	350	325	15	180	130	160	334	852	300	210				320	254	21	226	100	
32-200.1/1502 ³⁾	160M	x	x	50	32	80	128	137	70	350	325	15	180	130	160	334	852	300	210				320	254	21	226	100	
32-250.1/552 ³⁾	132S	x		50	32	100	164	171	55	300	266	12	225	162	132	282	706	220	140				270	216	15	193	100	
32-250.1/752 ³⁾	132S	x		50	32	100	164	171	55	300	266	12	225	162	132	282	706	220	140				270	216	15	193	100	
32-250.1/1102 ³⁾	160M	x		50	32	100	164	171	70	350	325	15	225	162	160	334	872	300	210				320	254	21	226	100	
32-250.1/1502 ³⁾	160M	x		50	32	100	164	171	70	350	325	15	225	162	160	334	872	300	210				320	254	21	226	100	
32-125/112	80	x		50	32	80	113	113		200	162	160	140	103		118	505				225	130					156	100
32-125/152	90S	x	x	50	32	80	113	113		200	190	160	140	103		118	518				225	130					156	100
32-125/222	90L	x	x	50	32	80	113	113		200	190	160	140	103		118	544				225	130					156	100
32-125/302	100L	x	x	50	32	80	113	113		250	213	160	140	103		118	597				225	130					170	100
32-125/402	112M	x	x	50	32	80	113	113		250	234	160	140	103		118	621				225	130					170	100
32-125/552 ³⁾	132S	x	x	50	32	80	113	113	55	300	266	12	140	103	132	282	686	220	140				270	216	15	193	100	
32-160/222	90L	x		50	32	80	113	125		200	190	160	160	115		118	544				225	130					156	100
32-160/302	100L	x	x	50	32	80	113	125		250	213	160	160	115		118	597				225	130					170	100
32-160/402	112M	x	x	50	32	80	113	125		250	234	160	160	115		118	621				225	130					170	100
32-160/552 ³⁾	132S	x	x	50	32	80	113	125	55	300	266	12	160	115	132	282	686	220	140				270	216	15	193	100	
32-160/752 ³⁾	132S	x	x	50	32	80	113	125	55	300	266	12	160	115	132	282	686	220	140				270	216	15	193	100	
32-200/402	112M	x		50	32	80	132	141		250	234	160	180	133		118	621				225	130					170	100
32-200/552 ³⁾	132S	x	x	50	32	80	132	141	55	300	266	12	180	133	132	282	686	220	140				270	216	15	193	100	
32-200/752 ³⁾	132S	x	x	50	32	80	132	141	55	300	266	12	180	133	132	282	686	220	140				270	216	15	193	100	
32-200/1102 ³⁾	160M	x	x	50	32	80	132	141	70	350	325	15	180	133	160	334	852	300	210				320	254	21	226	100	
32-200/1502 ³⁾	160M	x	x	50	32	80	132	141	70	350	325	15	180	133	160	334	852	300	210				320	254	21	226	100	
32-250/752 ³⁾	132S	x		50	32	100	170	176	55	300	266	12	225	168	132	282	706	220	140				270	216	15	193	100	
32-250/1102 ³⁾	160M	x		50	32	100	170	176	70	350	325	15	225	168	160	334	872	300	210				320	254	21	226	100	
32-250/1502 ³⁾	160M	x		50	32	100	170	176	70	350	325	15	225	168	160	334	872	300	210				320	254	21	226	100	

1) Rc = ISO 7/1; G = ISO 228/1
 2) DN = EN 1092-2/DN../PN 16/21/JL1040/B

3) bei diesen Baugrößen sind die Motorfüße 20 mm zu unterbauen
 3) the motor feet of these sizes are to be underpinned by 20 mm thick shims
 3) Il faut appuyer les pieds de moteur de ces tailles de construction avec des feuillets de 20 mm
 3) Con queste grandezze sotto i piedi del motore si devono sistemare degli spessori da 20 mm
 3) Bij deze grootten dienen de motorvoeten 20 mm opgevuuld te worden

4) $h_3 \geq h_4$

Etabloc GN, MN 40-125/... bis 50-160/..., n = 2900 1/min, n = 3500 1/min

mit Stützfuß (bis Motorbaugröße 112 = 4 kW)
 mit Motorfuß (ab Motorbaugröße 132 = 5,5 kW)
 with support foot (up to motor size 112 = 4 kW)
 with motor foot (motor size 132 = 5.5 kW and above)
 avec béquille (jusqu'à taille de moteur 112 = 4 kW)

avec pied de moteur (à partir de la taille de moteur 132 = 5,5 kW)
 con piede angolare (fino alla grandezza del motore 112 = 4 kW)
 con piede di fusione (a partire della grandezza del motore 132 = 5,5 kW)
 met voetsteun (tot motorgrootte 112 = 4 kW)
 met motorvoet (vanaf motorgrootte 132 = 5,5 kW)

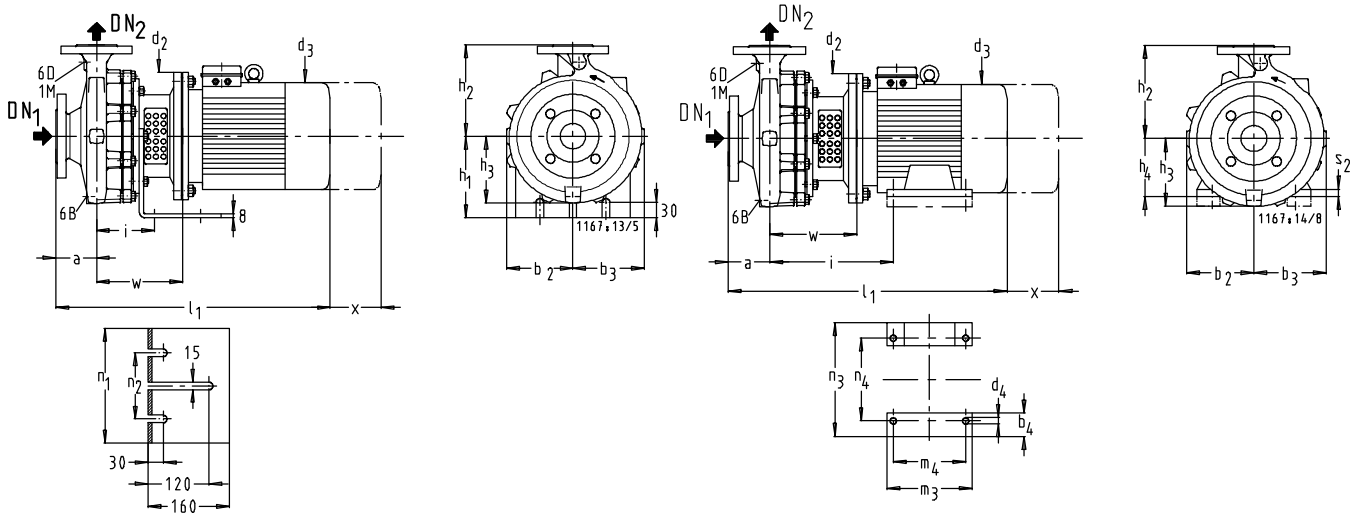

		Etabloc G, M Etabloc GN, MN, BN		Etabloc SN, CN	
		DN ₂ 32 - DN ₂ 80	DN ₂ 100	DN ₂ 32 - DN ₂ 80	DN ₂ 100 - DN ₂ 150
1 M	Druckmessgerät-Anschluss / Pressure gauge connection / Indicateur de pression / Manomètre / Manometro / Manometer	Rc 3/8 ¹⁾	Rc 1/2 ¹⁾	G 3/8 ¹⁾	G 1/2 ¹⁾
6 B	Förderflüssigkeit-Entleerung / Casing drain / Vidange du liquide pompé / Scarico del liquido convogliato / Vloeistof- aftap	Rc 3/8 ¹⁾	Rc 1/2 ¹⁾	G 3/8 ¹⁾	G 1/2 ¹⁾
6 D	Förderflüssigkeit-Auffüllen und Entlüften / Filling and venting of medium handled / Remplissage et purge d'air du liquide pompé / Riempimento del liquido convogliato spurgo dell'aria / Vloeistof vullen en ontluften	Rc 3/8 ¹⁾	Rc 1/2 ¹⁾	G 3/8 ¹⁾	G 1/2 ¹⁾

mm

Etabloc GN, MN	M	n = 2900	n = 3500	Toleranz der Anschlussmaße nach EN 735																									
				DN ₁ 2)	DN ₂ 2)	a	b ₂ ≈	b ₃ ≈	b ₄ ≈	d ₂	d ₃ ≈	d ₄	h ₁	h ₂	h ₃	h ₄	i	l ₁ ≈	m ₃ ≈	m ₄	n ₁	n ₂	n ₃ ≈	n ₄	s ₂	w	x		
40-125/152	90S	x		65	40	80	113	113		200	190		160	140	103		118	518			225	130					156	100	
40-125/222	90L	x	x	65	40	80	113	113		200	190		160	140	103		118	544			225	130					156	100	
40-125/302	100L	x	x	65	40	80	113	113		250	213		160	140	103		118	597			225	130					170	100	
40-125/402	112M	x	x	65	40	80	113	113		250	234		160	140	103		118	621			225	130					170	100	
40-125/552 ³⁾	132S		x	65	40	80	113	113	55	300	266	12		140	103	132	282	686	220	140					270	216	15	193	100
40-125/752 ³⁾	132S		x	65	40	80	113	113	55	300	266	12		140	103	132	282	686	220	140					270	216	15	193	100
40-125/1102 ³⁾	160M		x	65	40	80	113	113	70	350	325	15		140	103	160	334	852	300	210				320	254	21	226	100	
40-160/302	100L	x		65	40	80	115	131		250	213		160	160	118		118	597			225	130					170	100	
40-160/402	112M	x	x	65	40	80	115	131		250	234		160	160	118		118	621			225	130					170	100	
40-160/552 ³⁾	132S	x	x	65	40	80	115	131	55	300	266	12		160	118	132	282	686	220	140				270	216	15	193	100	
40-160/752 ³⁾	132S	x	x	65	40	80	115	131	55	300	266	12		160	118	132	282	686	220	140				270	216	15	193	100	
40-160/1102 ³⁾	160M	x	x	65	40	80	115	131	70	350	325	15		160	118	160	334	852	300	210				320	254	21	226	100	
40-160/1502 ³⁾	160M		x	65	40	80	115	131	70	350	325	15		160	118	160	334	852	300	210				320	254	21	226	100	
40-200/552 ³⁾⁴⁾	132S	x		65	40	100	140	152	55	300	266	12		180	140	132	282	706	220	140				270	216	15	193	100	
40-200/752 ³⁾⁴⁾	132S	x	x	65	40	100	140	152	55	300	266	12		180	140	132	282	706	220	140				270	216	15	193	100	
40-200/1102 ³⁾	160M	x	x	65	40	100	140	152	70	350	325	15		180	140	160	334	872	300	210				320	254	21	226	100	
40-200/1502 ³⁾	160M	x	x	65	40	100	140	152	70	350	325	15		180	140	160	334	872	300	210				320	254	21	226	100	
40-200/1852 ³⁾	160L		x	65	40	100	140	152	70	350	325	15		180	140	160	334	878	314	254				320	254	21	226	100	
40-200/2202	180M		x	65	40	100	140	152	80	350	370	15		180	140	180	347	936	320	241				360	279	23	226	100	
40-250/1102 ³⁾⁴⁾	160M	x		65	40	100	165	178	70	350	325	15		225	168	160	334	872	300	210				320	254	21	226	100	
40-250/1502 ³⁾⁴⁾	160M	x		65	40	100	165	178	70	350	325	15		225	168	160	334	878	314	254				320	254	21	226	100	
40-250/1852 ³⁾⁴⁾	160L	x		65	40	100	165	178	70	350	325	15		225	168	160	334	878	314	254				320	254	21	226	100	
40-250/2202	180M	x		65	40	100	165	178	80	350	370	15		225	168	180	347	936	320	241				360	279	23	226	100	
50-125/302	100L	x		65	50	100	113	128		250	213		160	160	112		118	617			225	130					170	100	
50-125/402	112M	x		65	50	100	113	128		250	234		160	160	112		118	641			225	130					170	100	
50-125/552 ³⁾	132S	x	x	65	50	100	113	128	55	300	266	12		160	112	132	282	706	220	140				270	216	15	193	100	
50-125/752 ³⁾	132S	x	x	65	50	100	113	128	55	300	266	12		160	112	132	282	706	220	140				270	216	15	193	100	
50-125/1102 ³⁾	160M		x	65	50	100	113	128	70	350	325	15		160	112	160	334	872	300	210				320	254	21	226	100	
50-125/1502 ³⁾	160M		x	65	50	100	113	128	70	350	325	15		160	112	160	334	872	300	210				320	254	21	226	100	
50-160/552 ³⁾⁴⁾	132S	x	x	65	50	100	126	147	55	300	266	12		180	134	132	282	706	220	140				270	216	15	193	100	
50-160/752 ³⁾⁴⁾	132S	x	x	65	50	100	126	147	55	300	266	12		180	134	132	282	706	220	140				270	216	15	193	100	
50-160/1102 ³⁾	160M	x	x	65	50	100	126	147	70	350	325	15		180	134	160	334	872	300	210				320	254	21	226	100	
50-160/1502 ³⁾	160M	x	x	65	50	100	126	147	70	350	325	15		180	134	160	334	872	300	210				320	254	21	226	100	
50-160/1852 ³⁾	160L		x	65	50	100	126	147	70	350	325	15		180	134	160	334	878	314	254				320	254	21	226	100	
50-160/2202	180M		x	65	50	100	126	147	80	350	370	15		180	134	180	347	936	320	241				360	279	23	226	100	

1) Rc = ISO 7/1; G = ISO 228/1

2) DN = EN 1092-2/DN../PN 16/21/JL1040/B

3) bei diesen Baugrößen sind die Motorfüße 20 mm zu unterbauen

3) the motor feet of these sizes are to be underpinned by 20 mm thick shims

3) Il faut appuyer les pieds de moteur de ces tailles de construction avec des feuillets de 20 mm

3) Con queste grandezze sotto i piedi del motore si devono sistemare degli spessori da 20 mm

3) Bij deze grootten dienen de motorvoeten 20 mm opgevuld te worden

 4) h₃ ≥ h₄

Etabloc GN, MN 50-200/... bis 100-160/..., n = 2900 1/min, n = 3500 1/min

mit Stützfuß (bis Motorbaugröße 112 = 4 kW)
 mit Motorfuß (ab Motorbaugröße 132 = 5,5 kW)
 with support foot (up to motor size 112 = 4 kW)
 with motor foot (motor size 132 = 5.5 kW and above)
 avec béquille (jusqu'à taille de moteur 112 = 4 kW)

avec pied de moteur (à partir de la taille de moteur 132 = 5,5 kW)
 con piede angolare (fino alla grandezza del motore 112 = 4 kW)
 con piede di fusione (a partire della grandezza del motore 132 = 5,5 kW)
 met voetsteun (tot motorgrootte 112 = 4 kW)
 met motorvoet (vanaf motorgrootte 132 = 5,5 kW)

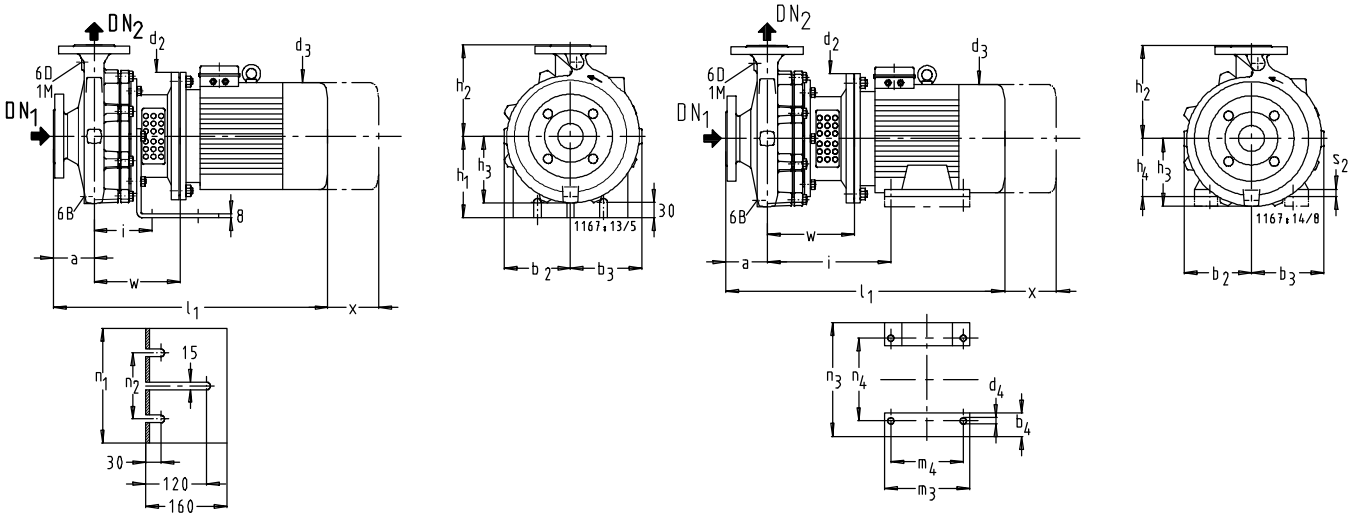

		Etabloc G, M Etabloc GN, MN, BN		Etabloc SN, CN	
		DN ₂ 32 - DN ₂ 80	DN ₂ 100	DN ₂ 32 - DN ₂ 80	DN ₂ 100 - DN ₂ 150
1 M	Druckmessgerät-Anschluss / Pressure gauge connection / Indicateur de pression / Manomètre / Manometro / Manometer	Rc 3/8 ¹⁾	Rc 1/2 ¹⁾	G 3/8 ¹⁾	G 1/2 ¹⁾
6 B	Förderflüssigkeit-Entleerung / Casing drain / Vidange du liquide pompé / Scarico del liquido convogliato / Vloeistof- aftap	Rc 3/8 ¹⁾	Rc 1/2 ¹⁾	G 3/8 ¹⁾	G 1/2 ¹⁾
6 D	Förderflüssigkeit-Auffüllen und Entlüften / Filling and venting of medium handled / Remplissage et purge d'air du liquide pompé / Riempimento del liquido convogliato spurgo dell'aria / Vloeistof vullen en ontluften	Rc 3/8 ¹⁾	Rc 1/2 ¹⁾	G 3/8 ¹⁾	G 1/2 ¹⁾

mm

Etabloc GN, MN	M	n = 2900	n = 3500	Toleranz der Anschlussmaße nach EN 735																								
				DN ₁ 2)	DN ₂ 2)	a	b ₂ ≈	b ₃ ≈	b ₄ ≈	d ₂	d ₃ ≈	d ₄	h ₁	h ₂	h ₃	h ₄	i	l ₁ ≈	m ₃ ≈	m ₄	n ₁	n ₂	n ₃ ≈	n ₄	s ₂	w	x	
50-200/1102 ³⁾	160M	x	x	65	50	100	145	165	70	350	325	15	200	152	160	334	872	300	210					320	254	21	226	100
50-200/1502 ³⁾	160M	x	x	85	50	100	145	165	70	350	325	15	200	152	160	334	872	300	210					320	254	21	226	100
50-200/1852 ³⁾	160L	x	x	65	50	100	145	165	70	350	325	15	200	152	160	334	878	314	254					320	254	21	226	100
50-200/2202	180M	x	x	65	50	100	145	165	80	350	370	15	200	152	180	347	936	320	241					360	279	23	226	100
50-250/1502 ^{3)/4)}	160M	x		65	50	100	168	184	70	350	325	15	225	172	160	334	872	300	210					320	254	21	226	100
50-250/1852 ^{3)/4)}	160L	x		65	50	100	168	184	70	350	325	15	225	172	160	334	878	314	254					320	254	21	226	100
50-250/2202	180M	x		65	50	100	168	184	80	350	370	15	225	172	180	347	936	320	241					360	279	23	226	100
65-125/402	112M	x		80	65	100	120	148		250	234		160	180	132		118	641			225	130					170	100
65-125/552 ^{3)/4)}	132S	x	x	80	65	100	120	148	55	300	266	12		180	132	132	282	706	220	140			270	216	15	193	100	
65-125/752 ^{3)/4)}	132S	x	x	80	65	100	120	148	55	300	266	12		180	132	132	282	706	220	140			270	216	15	193	100	
65-125/1102 ³⁾	160M	x	x	80	65	100	120	148	70	350	325	15		180	132	160	334	872	300	210			320	254	21	226	100	
65-125/1502 ³⁾	160M	x		80	65	100	120	148	70	350	325	15		180	132	160	334	872	300	210			320	254	21	226	100	
65-160/752 ^{3)/4)}	132S	x		80	65	100	130	158	55	300	266	12		200	140	132	282	706	220	140			270	216	15	193	100	
65-160/1102 ³⁾	160M	x	x	80	65	100	130	158	70	350	325	15		200	140	160	334	872	300	210			320	254	21	226	100	
65-160/1502 ³⁾	160M	x	x	80	65	100	130	158	70	350	325	15		200	140	160	334	872	300	210			320	254	21	226	100	
65-160/1852 ³⁾	160L	x		80	65	100	130	158	70	350	325	15		200	140	160	334	878	314	254			320	254	21	226	100	
65-160/2202	180M	x		80	65	100	130	158	80	350	370	15		200	140	180	347	936	320	241			360	279	23	226	100	
65-200/1502 ^{3)/4)}	160M	x		80	65	100	154	177	70	350	325	15		225	161	160	334	872	300	210			320	254	21	226	140	
65-200/1852 ^{3)/4)}	160L	x	x	80	65	100	154	177	70	350	325	15		225	161	160	334	878	314	254			320	254	21	226	140	
65-200/2202	180M	x	x	80	65	100	154	177	80	350	370	15		225	161	180	347	936	320	241			360	279	23	226	140	
65-250/2202 ⁴⁾	180M	x		80	65	100	180	200	80	350	370	15		250	186	180	367	956	320	241			360	279	23	246	140	
80-160/1102 ^{3)/4)}	160M	x		100	80	125	153	192	70	350	325	15		225	168	160	334	897	300	210			320	254	21	226	140	
80-160/1502 ^{3)/4)}	160M	x		100	80	125	153	192	70	350	325	15		225	168	160	334	897	300	210			320	254	21	226	140	
80-160/1852 ^{3)/4)}	160L	x		100	80	125	153	192	70	350	325	15		225	168	160	334	903	314	254			320	254	21	226	140	
80-160/2202	180M	x	x	100	80	125	153	192	80	350	370	15		225	168	180	347	961	320	241			360	279	23	226	140	
80-200/1852 ^{3)/4)}	160L	x		100	80	125	161	189	70	350	325	15		250	170	160	354	923	314	254			320	254	21	246	140	
80-200/2202	180M	x		100	80	125	161	189	80	350	370	15		250	170	180	367	981	320	241			360	279	23	246	140	
100-160/2202 ⁴⁾	180M	x		125	100	125	178	225	80	350	370	15		280	196	180	367	981	320	241			360	279	23	246	140	

1) Rc = ISO 7/1; G = ISO 228/1
 2) DN = EN 1092-2/DN.../PN 16/21/JL1040/B

3) bei diesen Baugrößen sind die Motorfüße 20 mm zu unterbauen
 3) the motor feet of these sizes are to be underpinned by 20 mm thick shims
 3) Il faut appuyer les pieds de moteur de ces tailles de construction avec des feuillards de 20 mm
 3) Con queste grandezze sotto i piedi del motore si devono sistemare degli spessori da 20 mm
 3) Bij deze grootten dienen de motorvoeten 20 mm opgevuld te worden

4) h₃ ≥ h₄

Etabloc GN, MN 32-125.1/... bis 40-125/..., n = 1450 1/min, n = 1750 1/min

mit Stützfuß (bis Motorbaugröße 112 = 4 kW)
 mit Motorfuß (ab Motorbaugröße 132 = 5,5 kW)
 with support foot (up to motor size 112 = 4 kW)
 with motor foot (motor size 132 = 5.5 kW and above)
 avec béquille (jusqu'à taille de moteur 112 = 4 kW)

avec pied de moteur (à partir de la taille de moteur 132 = 5,5 kW)
 con piede angolare (fino alla grandezza del motore 112 = 4 kW)
 con piede di fusione (a partire della grandezza del motore 132 = 5,5 kW)
 met voetsteun (tot motorgrootte 112 = 4 kW)
 met motorvoet (vanaf motorgrootte 132 = 5,5 kW)

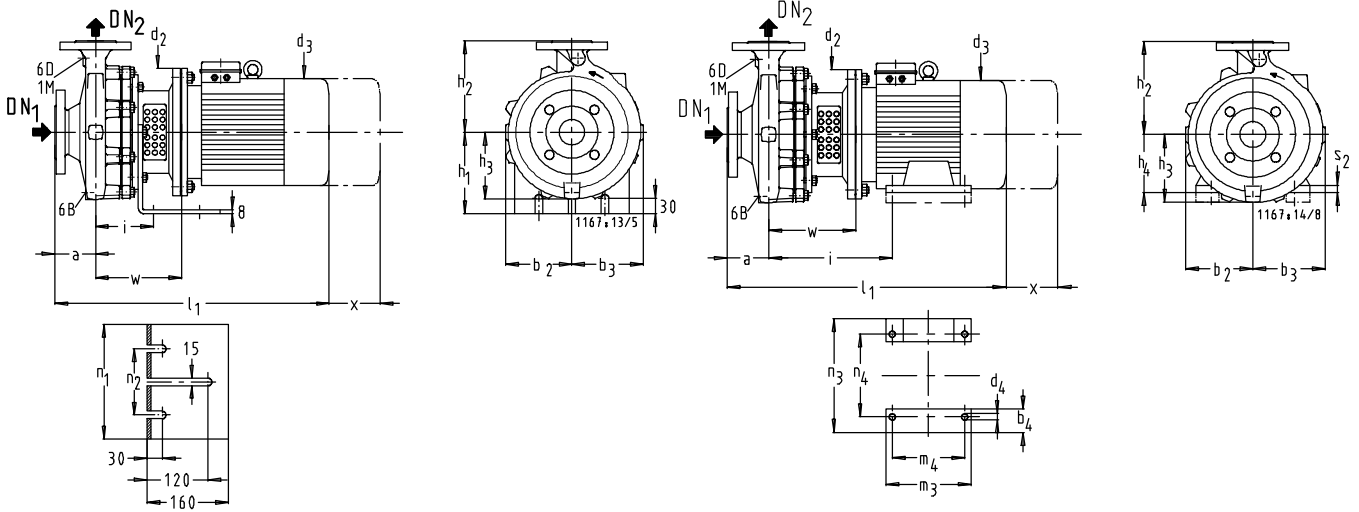

		Etabloc G, M Etabloc GN, MN, BN		Etabloc SN, CN	
		DN ₂ 32 - DN ₂ 80	DN ₂ 100	DN ₂ 32 - DN ₂ 80	DN ₂ 100 - DN ₂ 150
1 M	Druckmessgerät-Anschluss / Pressure gauge connection / Indicateur de pression / Manomètre / Manometro / Manometer	Rc 3/8 ¹⁾	Rc 1/2 ¹⁾	G 3/8 ¹⁾	G 1/2 ¹⁾
6 B	Förderflüssigkeit-Entleerung / Casing drain / Vidange du liquide pompé / Scarico del liquido convogliato / Vloeistof- aftap	Rc 3/8 ¹⁾	Rc 1/2 ¹⁾	G 3/8 ¹⁾	G 1/2 ¹⁾
6 D	Förderflüssigkeit-Auffüllen und Entlüften / Filling and venting of medium handled / Remplissage et purge d'air du liquide pompé / Riempimento del liquido convogliato spurgo dell'aria / Vloeistof vullen en ontluften	Rc 3/8 ¹⁾	Rc 1/2 ¹⁾	G 3/8 ¹⁾	G 1/2 ¹⁾

Etabloc GN, MN	M	n=1450	n=1750	Toleranz der Anschlussmaße nach EN 735																							
				DN ₁ 2)	DN ₂ 2)	a	b ₂ ≈	b ₃ ≈	b ₄ ≈	d ₂	d ₃ ≈	d ₄	h ₁	h ₂	h ₃	h ₄	i	l ₁ ≈	m ₃ ≈	m ₄	n ₁	n ₂	n ₃ ≈	n ₄	s ₂	w	x
32-125.1/024	71	x	x	50	32	80	113	113	160	145	160	140	103	118	453		225	130								136	100
32-125.1/034	71	x	x	50	32	80	113	113	160	145	160	140	103	118	453		225	130								136	100
32-125.1/054	80	x	x	50	32	80	113	113	200	162	160	140	103	118	491		225	130								156	100
32-160.1/034	71	x	x	50	32	80	116	125	160	145	160	160	115	118	453		225	130								136	100
32-160.1/054	80	x	x	50	32	80	116	125	200	162	160	160	115	118	491		225	130								156	100
32-160.1/074	80		x	50	32	80	116	125	200	162	160	160	115	118	491		225	130								156	100
32-160.1/114	90S		x	50	32	80	116	125	200	190	160	160	115	118	518		225	130								156	100
32-200.1/054	80	x	x	50	32	80	128	137	200	162	160	180	130	118	491		225	130								156	100
32-200.1/074	80	x	x	50	32	80	128	137	200	162	160	180	130	118	491		225	130								156	100
32-200.1/114	90S		x	50	32	80	128	137	200	190	160	180	130	118	518		225	130								156	100
32-200.1/154	90L		x	50	32	80	128	137	200	190	160	180	130	118	544		225	130								156	100
32-200.1/224	100L		x	50	32	80	128	137	250	213	160	180	130	118	597		225	130								170	100
32-250.1/074 ⁴⁾	80	x		50	32	100	164	171	200	162	160	225	162	118	511		225	130								156	100
32-250.1/114 ⁴⁾	90S	x	x	50	32	100	164	171	200	190	160	225	162	118	538		225	130								156	100
32-250.1/154 ⁴⁾	90L	x	x	50	32	100	164	171	200	190	160	225	162	118	564		225	130								156	100
32-250.1/224 ⁴⁾	100L		x	50	32	100	164	171	250	213	160	225	162	118	617		225	130								170	100
32-250.1/304 ⁴⁾	100L		x	50	32	100	164	171	250	213	160	225	162	118	652		225	130								170	100
32-125/034	71	x	x	50	32	80	113	113	160	145	160	140	103	118	453		225	130								136	100
32-125/054	80	x	x	50	32	80	113	113	200	162	160	140	103	118	491		225	130								156	100
32-125/074	80		x	50	32	80	113	113	200	162	160	140	103	118	491		225	130								156	100
32-160/054	80	x	x	50	32	80	113	125	200	162	160	160	115	118	491		225	130								156	100
32-160/074	80		x	50	32	80	113	125	200	162	160	160	115	118	491		225	130								156	100
32-160/114	90S		x	50	32	80	113	125	200	190	160	160	115	118	518		225	130								156	100
32-200/054	80	x		50	32	80	132	141	200	162	160	180	133	118	491		225	130								156	100
32-200/074	80	x	x	50	32	80	132	141	200	162	160	180	133	118	491		225	130								156	100
32-200/114	90S	x	x	50	32	80	132	141	200	190	160	180	133	118	518		225	130								156	100
32-200/154	90L		x	50	32	80	132	141	200	190	160	180	133	118	544		225	130								156	100
32-200/224	100L		x	50	32	80	132	141	250	213	160	180	133	118	597		225	130								170	100
32-250/114 ⁴⁾	90S	x		50	32	100	170	176	200	190	160	225	168	118	538		225	130								156	100
32-250/154 ⁴⁾	90L	x		50	32	100	170	176	200	190	160	225	168	118	564		225	130								156	100
32-250/224 ⁴⁾	100L	x	x	50	32	100	170	176	250	213	160	225	168	118	617		225	130								170	100
32-250/304 ⁴⁾	100L		x	50	32	100	170	176	250	213	160	225	168	118	652		225	130								170	100
32-250/404 ⁴⁾	112M		x	50	32	100	170	176	250	234	160	225	168	118	641		225	130								170	100
32-250/554 ^{3)/4)}	132S		x	50	32	100	170	176	55	300	266	12	225	168	132	282	706	220	140				270	216	15	193	100
40-125/024	71	x		65	40	80	113	113	160	145	160	140	103	118	453		225	130								136	100
40-125/034	71	x		65	40	80	113	113	160	145	160	140	103	118	453		225	130								136	100
40-125/054	80	x	x	65	40	80	113	113	200	162	160	140	103	118	491		225	130								156	100
40-125/074	80		x	65	40	80	113	113	200	162	160	140	103	118	491		225	130								156	100
40-125/114	90S		x	65	40	80	113	113	200	190	160	140	103	118	518		225	130								156	100

1) Rc = ISO 7/1;
G = ISO 228/1

2) DN = EN 1092-2/DN./PN 16/21/JL1040/B

3) bei diesen Baugrößen sind die Motorfüße 20 mm zu unterbauen

3) the motor feet of these sizes are to be underpinned by 20 mm thick shims

3) Il faut appuyer les pieds de moteur de ces tailles de construction avec des feuillards de 20 mm

3) Con queste grandezze sotto i piedi del motore si devono sistemare degli spessori da 20 mm

3) Bij deze grootten dienen de motorvoeten 20 mm opgevuld te worden

4) $h_3 \geq h_1 / h_3 \geq h_4$

Etabloc GN, MN 40-160/... bis 50-200/..., n = 1450 1/min, n = 1750 1/min

mit Stützfuß (bis Motorbaugröße 112 = 4 kW)
 mit Motorfuß (ab Motorbaugröße 132 = 5,5 kW)
 with support foot (up to motor size 112 = 4 kW)
 with motor foot (motor size 132 = 5.5 kW and above)
 avec béquille (jusqu'à taille de moteur 112 = 4 kW)

avec pied de moteur (à partir de la taille de moteur 132 = 5,5 kW)
 con piede angolare (fino alla grandezza del motore 112 = 4 kW)
 con piede di fusione (a partire della grandezza del motore 132 = 5,5 kW)
 met voetsteun (tot motorgrootte 112 = 4 kW)
 met motorvoet (vanaf motorgrootte 132 = 5,5 kW)

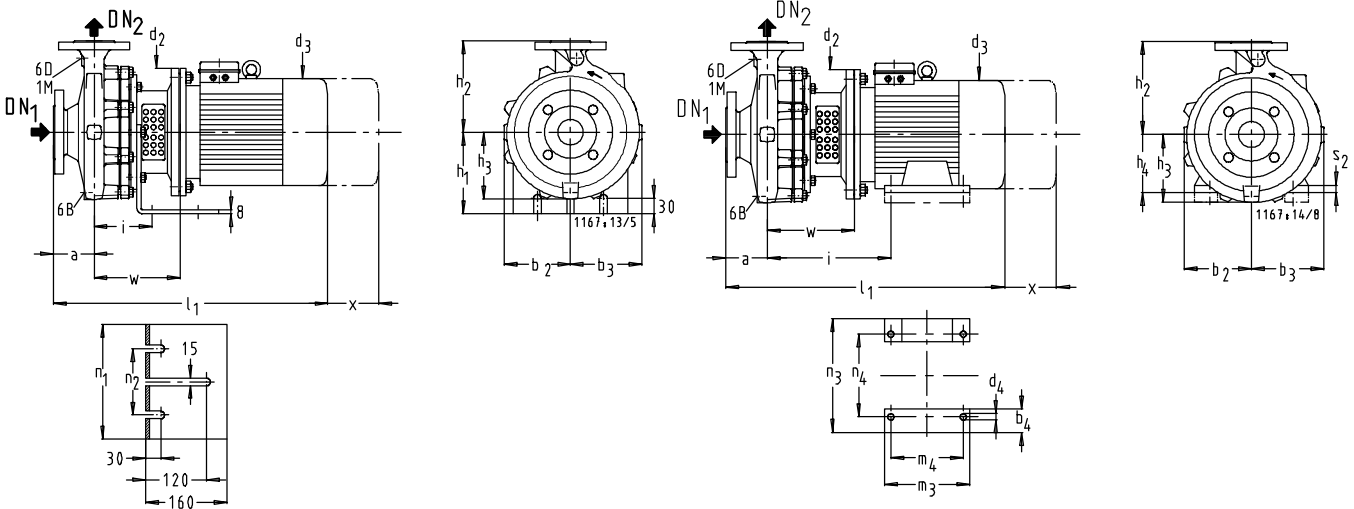

		Etabloc G, M		Etabloc SN, CN	
		Etabloc GN, MN, BN			
		DN ₂ 32 - DN ₂ 80	DN ₂ 100	DN ₂ 32 - DN ₂ 80	DN ₂ 100 - DN ₂ 150
1 M	Druckmessgerät-Anschluss / Pressure gauge connection / Indicateur de pression / Manomètre / Manometro / Manometer	Rc 3/8 ¹⁾	Rc 1/2 ¹⁾	G 3/8 ¹⁾	G 1/2 ¹⁾
6 B	Förderflüssigkeit-Entleerung / Casing drain / Vidange du liquide pompé / Scarico del liquido convogliato / Vloeistof- aftap	Rc 3/8 ¹⁾	Rc 1/2 ¹⁾	G 3/8 ¹⁾	G 1/2 ¹⁾
6 D	Förderflüssigkeit-Auffüllen und Entlüften / Filling and venting of medium handled / Rempissage et purge d'air du liquide pompé / Riempimento del liquido convogliato spurgo dell'aria / Vloeistof vullen en ontluften	Rc 3/8 ¹⁾	Rc 1/2 ¹⁾	G 3/8 ¹⁾	G 1/2 ¹⁾

mm

Etabloc GN, MN	Ⓜ	n= 1450	n= 1750	Toleranz der Anschlussmaße nach EN 735																							
				DN ₁ 2)	DN ₂ 2)	a	b ₂ ≈	b ₃ ≈	b ₄ ≈	d ₂	d ₃ ≈	d ₄	h ₁	h ₂	h ₃	h ₄	i	l ₁ ≈	m ₃ ≈	m ₄	n ₁	n ₂	n ₃ ≈	n ₄	s ₂	w	x
40-160/054	80	x		65	40	80	115	131		200	162	160	160	118	118	491				225	130					156	100
40-160/074	80	x	x	65	40	80	115	131		200	162	160	160	118	118	491				225	130					156	100
40-160/114	90S	x	x	65	40	80	115	131		200	190	160	160	118	118	518				225	130					156	100
40-160/154	90L	x		65	40	80	115	131		200	190	160	160	118	118	544				225	130					156	100
40-160/224	100L		x	65	40	80	115	131		250	213	160	160	118	118	597				225	130					170	100
40-200/074	80	x		65	40	100	140	152		200	162	160	180	140	118	511				225	130					156	100
40-200/114	90S	x		65	40	100	140	152		200	190	160	180	140	118	538				225	130					156	100
40-200/154	90L	x	x	65	40	100	140	152		200	190	160	180	140	118	564				225	130					156	100
40-200/224	100L		x	65	40	100	140	152		250	213	160	180	140	118	617				225	130					170	100
40-200/304	100L		x	65	40	100	140	152		250	213	160	180	140	118	652				225	130					170	100
40-250/114 ⁴⁾	90S	x		65	40	100	165	178		200	190	160	225	168	118	538				225	130					156	100
40-250/154 ⁴⁾	90L	x		65	40	100	165	178		200	190	160	225	168	118	564				225	130					156	100
40-250/224 ⁴⁾	100L	x	x	65	40	100	165	178		250	213	160	225	168	118	617				225	130					170	100
40-250/304 ⁴⁾	100L	x	x	65	40	100	165	178		250	213	160	225	168	118	652				225	130					170	100
40-250/404 ⁴⁾	112M		x	65	40	100	165	178		250	234	160	225	168	118	641				225	130					170	100
40-250/554 ³⁾⁴⁾	132S		x	65	40	100	165	178	55	300	266	12		225	168	132	282	706	220	140			270	216	15	193	100
40-315/224 ⁴⁾	100L	x		65	40	125	194	203		250	213	180	250	196	142	662				260	180					190	100
40-315/304 ⁴⁾	100L	x		65	40	125	194	203		250	213	180	250	196	142	697				260	180					190	100
40-315/404 ⁴⁾	112M	x	x	65	40	125	194	203		250	234	180	250	196	142	686				260	180					190	100
40-315/554 ³⁾⁴⁾	132S	x	x	65	40	125	194	203	55	300	266	12		250	196	132	302	751	220	140			270	216	15	213	100
40-315/754 ³⁾⁴⁾	132M		x	65	40	125	194	203	59	300	298	12		250	196	132	302	779	240	178			270	216	15	213	100
40-315/1104 ³⁾⁴⁾	160M		x	65	40	125	194	203	70	350	325	15		250	196	160	354	917	300	210			320	254	21	246	100
50-125/054	80	x		65	50	100	113	128		200	162		160	160	112	511				225	130					156	100
50-125/074	80	x	x	65	50	100	113	128		200	162		160	160	112	511				225	130					156	100
50-125/114	90S	x	x	65	50	100	113	128		200	190		160	160	112	538				225	130					156	100
50-125/154	90L		x	65	50	100	113	128		200	190		160	160	112	564				225	130					156	100
50-160/074	80	x		65	50	100	126	147		200	162		160	180	134	511				225	130					156	100
50-160/114	90S	x	x	65	50	100	126	147		200	190		160	180	134	538				225	130					156	100
50-160/154	90L	x	x	65	50	100	126	147		200	190		160	180	134	564				225	130					156	100
50-160/224	100L		x	65	50	100	126	147		250	213		160	180	134	617				225	130					170	100
50-160/304	100L		x	65	50	100	126	147		250	213		160	180	134	652				225	130					170	100
50-200/154	90L	x		65	50	100	145	165		200	190		160	200	152	564				225	130					156	100
50-200/224	100L	x	x	65	50	100	145	165		250	213		160	200	152	617				225	130					170	100
50-200/304	100L	x	x	65	50	100	145	165		250	213		160	200	152	652				225	130					170	100
50-200/404	112M		x	65	50	100	145	165		250	234		160	200	152	641				225	130					170	100
50-200/554 ³⁾⁴⁾	132S		x	65	50	100	145	165	55	300	266	12		200	152	132	282	706	220	140			270	216	15	193	100

1) Rc = ISO 7/1; G = ISO 228/1

2) DN = EN 1092-2/DN../PN 16/21/JL1040/B

 3) bei diesen Baugrößen sind die Motorfüße 20 mm zu unterbauen
 3) the motor feet of these sizes are to be underpinned by 20 mm thick shims

 4) Δ h₃ ≥ h₁ / h₃ ≥ h₄

 3) Il faut appuyer les pieds de moteur de ces tailles de construction avec des feuilards de 20 mm
 3) Con queste grandezze sotto i piedi del motore si devono sistemare degli spessori di 20 mm
 3) Bij deze grootten dienen de motorvoeten 20 mm opgevuld te worden

Etabloc GN, MN 50-250/... bis 65-315/..., n = 1450 1/min, n = 1750 1/min

mit Stützfuß (bis Motorbaugröße 112 = 4 kW)
 mit Motorfuß (ab Motorbaugröße 132 = 5,5 kW)
 with support foot (up to motor size 112 = 4 kW)
 with motor foot (motor size 132 = 5.5 kW and above)
 avec béquille (jusqu'à taille de moteur 112 = 4 kW)

avec pied de moteur (à partir de la taille de moteur 132 = 5,5 kW)
 con piede angolare (fino alla grandezza del motore 112 = 4 kW)
 con piede di fusione (a partire della grandezza del motore 132 = 5,5 kW)
 met voetsteun (tot motorgrootte 112 = 4 kW)
 met motorvoet (vanaf motorgrootte 132 = 5,5 kW)

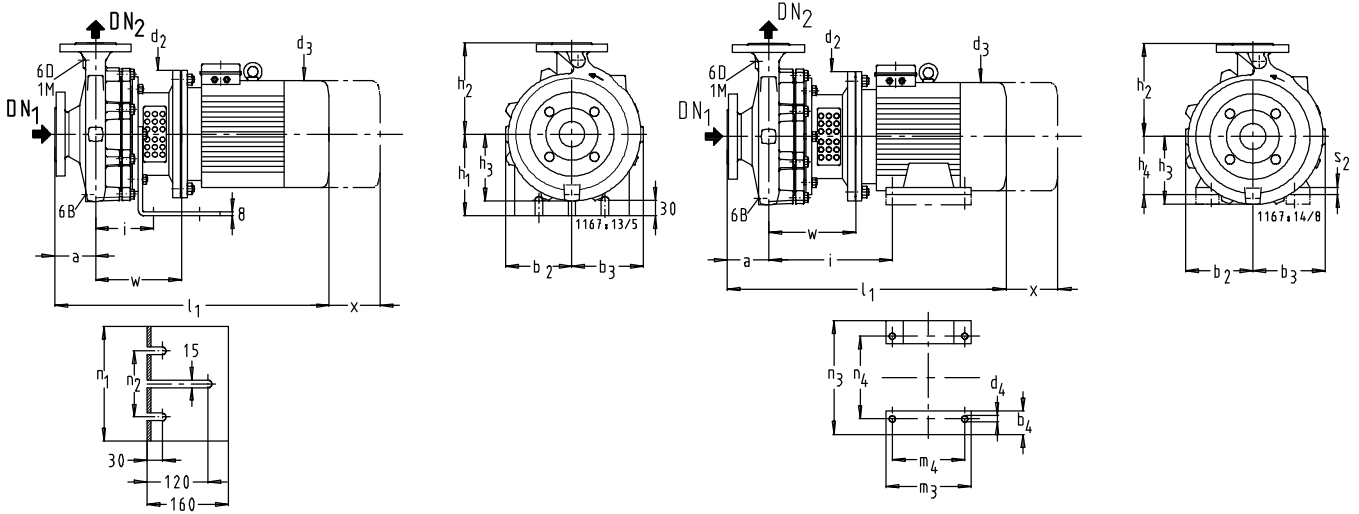

		Etabloc G, M Etabloc GN, MN, BN		Etabloc SN, CN	
		DN ₂ 32 - DN ₂ 80	DN ₂ 100	DN ₂ 32 - DN ₂ 80	DN ₂ 100 - DN ₂ 150
1 M	Druckmessgerät-Anschluss / Pressure gauge connection / Indicateur de pression / Manomètre / Manometro / Manometer	Rc 3/8 ¹⁾	Rc 1/2 ¹⁾	G 3/8 ¹⁾	G 1/2 ¹⁾
6 B	Förderflüssigkeit-Entleerung / Casing drain / Vidange du liquide pompé / Scarico del liquido convogliato / Vloeistof- aftap	Rc 3/8 ¹⁾	Rc 1/2 ¹⁾	G 3/8 ¹⁾	G 1/2 ¹⁾
6 D	Förderflüssigkeit-Auffüllen und Entlüften / Filling and venting of medium handled / Remplissage et purge d'air du liquide pompé / Riempimento del liquido convogliato spurgo dell'aria / Vloeistof vullen en ontluichten	Rc 3/8 ¹⁾	Rc 1/2 ¹⁾	G 3/8 ¹⁾	G 1/2 ¹⁾

Etabloc GN, MN	M	n= 1450	n= 1750	Toleranz der Anschlussmaße nach EN 735																								
				DN ₁ 2)	DN ₂ 2)	a	b ₂ =	b ₃ =	b ₄ =	d ₂	d ₃ =	d ₄	h ₁	h ₂	h ₃	h ₄	i	l ₁ =	m ₃ =	m ₄	n ₁	n ₂	n ₃ =	n ₄	s ₂	w	x	
50-250/224 ⁴⁾	100L	x	x	65	50	100	168	184		250	213		160	225	172		118	617				225	130				170	100
50-250/304 ⁴⁾	100L	x		65	50	100	168	184		250	213		160	225	172		118	652				225	130				170	100
50-250/404 ⁴⁾	112M	x	x	65	50	100	168	184		250	234		160	225	172		118	641				225	130				170	100
50-250/554 ³⁾⁴⁾	132S		x	65	50	100	168	184	55	300	266	12		225	172	132	282	706	220	140				270	216	15	193	100
50-250/754 ³⁾⁴⁾	132M		x	65	50	100	168	184	59	300	298	12		225	172	132	282	734	240	178				270	216	15	193	100
50-250/1104 ³⁾⁴⁾	160M		x	65	50	100	168	184	70	350	325	15		225	172	160	334	872	300	210				320	254	21	226	100
50-315/304 ⁴⁾	100L	x		65	50	125	200	216		250	213		180	280	204		142	697			260	180					190	100
50-315/404 ⁴⁾	112M	x		65	50	125	200	216		250	234		180	280	204		142	686			260	180					190	100
50-315/554 ³⁾⁴⁾	132S	x	x	65	50	125	200	216	55	300	266	12		280	204	132	302	751	220	140				270	216	15	213	100
50-315/754 ³⁾⁴⁾	132M	x	x	65	50	125	200	216	59	300	298	12		280	204	132	302	779	240	178				270	216	15	213	100
50-315/1104 ³⁾⁴⁾	160M		x	65	50	125	200	216	70	350	325	15		280	204	160	354	917	300	210				320	254	21	246	100
50-315/1504 ³⁾⁴⁾	160L		x	65	50	125	200	216	70	350	325	15		280	204	160	354	923	314	254				320	254	21	246	100
65-125/054	80	x		80	65	100	120	148		200	162		160	180	132		118	511			225	130					156	100
65-125/074	80	x	x	80	65	100	120	148		200	162		160	180	132		118	511			225	130					156	100
65-125/114	90S	x	x	80	65	100	120	148		200	190		160	180	132		118	538			225	130					156	100
65-125/154	90L	x	x	80	65	100	120	148		200	190		160	180	132		118	564			225	130					156	100
65-125/224	100L		x	80	65	100	120	148		250	213		160	180	132		118	617			225	130					170	100
65-160/114	90S	x		80	65	100	130	158		200	190		160	200	140		118	538			225	130					156	100
65-160/154	90L	x	x	80	65	100	130	158		200	190		160	200	140		118	564			225	130					156	100
65-160/224	100L	x	x	80	65	100	130	158		250	213		160	200	140		118	617			225	130					170	100
65-160/304	100L		x	80	65	100	130	158		250	213		160	200	140		118	652			225	130					170	100
65-160/404	112M		x	80	65	100	130	158		250	234		160	200	140		118	641			225	130					170	100
65-200/224 ⁴⁾	100L	x		80	65	100	154	177		250	213		160	225	161		118	637			225	130					170	140
65-200/304 ⁴⁾	100L	x		80	65	100	154	177		250	213		160	225	161		118	652			225	130					170	140
65-200/404 ⁴⁾	112M	x	x	80	65	100	154	177		250	234		160	225	161		118	641			225	130					170	140
65-200/554 ³⁾⁴⁾	132S		x	80	65	100	154	177	55	300	266	12		225	161	132	282	706	220	140				270	216	15	193	140
65-200/754 ³⁾⁴⁾	132M		x	80	65	100	154	177	59	300	298	12		225	161	132	282	734	240	178				270	216	15	193	140
65-250/304 ⁴⁾	100L	x		80	65	100	180	200		250	213		180	250	186		142	672			260	180					190	140
65-250/404 ⁴⁾	112M	x		80	65	100	180	200		250	234		180	250	186		142	661			260	180					190	140
65-250/554 ³⁾⁴⁾	132S	x	x	80	65	100	180	200	55	300	266	12		250	186	132	302	726	220	140				270	216	15	213	140
65-250/754 ³⁾⁴⁾	132M		x	80	65	100	180	200	59	300	298	12		250	186	132	302	754	240	178				270	216	15	213	140
65-250/1104 ³⁾⁴⁾	160M		x	80	65	100	180	200	70	350	325	15		250	186	160	354	892	300	210				320	254	21	246	140
65-315/554 ³⁾⁴⁾	132S	x		80	65	125	208	229	55	300	266	12		280	214	132	302	751	220	140				270	216	15	213	140
65-315/754 ³⁾⁴⁾	132M	x		80	65	125	208	229	59	300	298	12		280	214	132	302	779	240	178				270	216	15	213	140
65-315/1104 ³⁾⁴⁾	160M	x	x	80	65	125	208	229	70	350	325	15		280	214	160	354	917	300	210				320	254	21	246	140
65-315/1504 ³⁾⁴⁾	160L	x	x	80	65	125	208	229	70	350	325	15		280	214	160	354	923	314	254				320	254	21	246	140
65-315/1854 ⁴⁾	180M		x	80	65	125	208	229	80	350	370	15		280	214	180	367	981	320	241				360	279	23	246	140
65-315/2204 ⁴⁾	180L		x	80	65	125	208	229	80	350	370	15		280	214	180	367	981	358	279				360	279	23	246	140

1) Rc = ISO 7/1 2) DN = EN 1092-2/DN../PN 16/21/JL1040/B 3) bei diesen Baugrößen sind die Motorfüße 20 mm zu unterbauen 4) Δ $h_3 \geq h_1 / h_3 \geq h_4$
 3) the motor feet of these sizes are to be underpinned by 20 mm thick shims
 3) Il faut appuyer les pieds de moteur de ces tailles de construction avec des feuillards de 20 mm
 3) Con queste grandezze sotto i piedi del motore si devono sistemare degli spessori da 20 mm
 3) Bij deze grootten dienen de motorvoeten 20 mm opgevuld te worden

Etabloc GN, MN 80-160/... bis 100-250/..., n = 1450 1/min, n = 1750 1/min

mit Stützfuß (bis Motorbaugröße 112 = 4 kW)
 mit Motorfuß (ab Motorbaugröße 132 = 5,5 kW)
 with support foot (up to motor size 112 = 4 kW)
 with motor foot (motor size 132 = 5.5 kW and above)
 avec béquille (jusqu'à taille de moteur 112 = 4 kW)

avec pied de moteur (à partir de la taille de moteur 132 = 5,5 kW)
 con piede angolare (fino alla grandezza del motore 112 = 4 kW)
 con piede di fusione (a partire della grandezza del motore 132 = 5,5 kW)
 met voetsteun (tot motorgrootte 112 = 4 kW)
 met motorvoet (vanaf motorgrootte 132 = 5,5 kW)

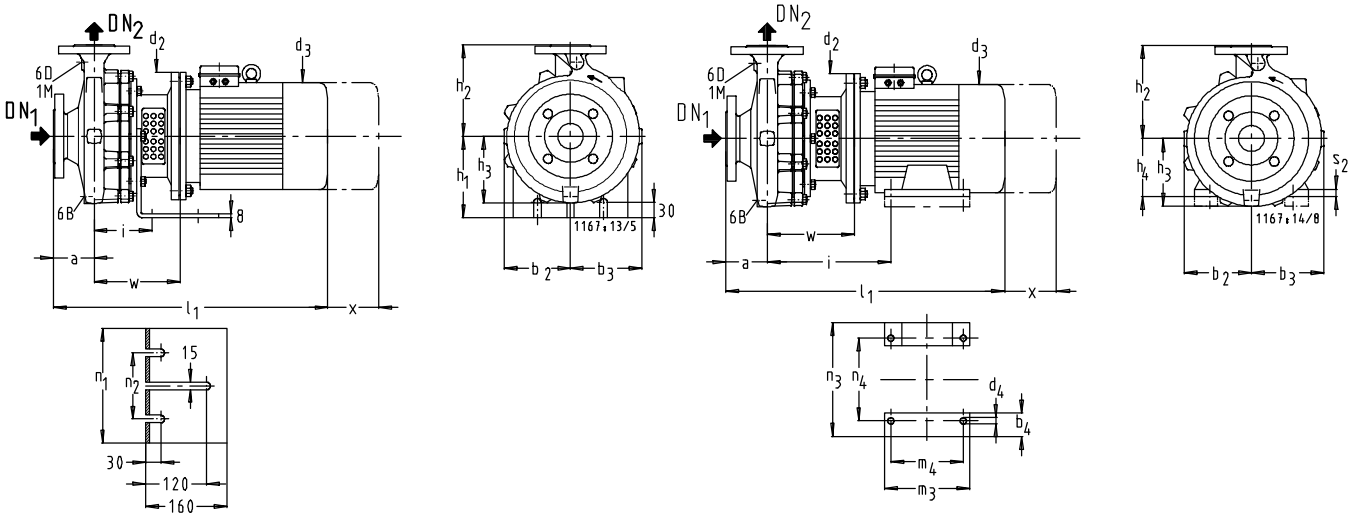

		Etabloc G, M Etabloc GN, MN, BN		Etabloc SN, CN	
		DN ₂ 32 - DN ₂ 80	DN ₂ 100	DN ₂ 32 - DN ₂ 80	DN ₂ 100 - DN ₂ 150
1 M	Druckmessgerät-Anschluss / Pressure gauge connection / Indicateur de pression / Manomètre / Manometro / Manometer	Rc 3/8 ¹⁾	Rc 1/2 ¹⁾	G 3/8 ¹⁾	G 1/2 ¹⁾
6 B	Förderflüssigkeit-Entleerung / Casing drain / Vidange du liquide pompé / Scarico del liquido convogliato / Vloeistof- aftap	Rc 3/8 ¹⁾	Rc 1/2 ¹⁾	G 3/8 ¹⁾	G 1/2 ¹⁾
6 D	Förderflüssigkeit-Auffüllen und Entlüften / Filling and venting of medium handled / Remplissage et purge d'air du liquide pompé / Riempimento del liquido convogliato spurgo dell'aria / Vloeistof vullen en ontluften	Rc 3/8 ¹⁾	Rc 1/2 ¹⁾	G 3/8 ¹⁾	G 1/2 ¹⁾

mm

Etabloc GN, MN	M	n= 1450	n= 1750	Toleranz der Anschlussmaße nach EN 735																								
				DN ₁ 2)	DN ₂ 2)	a	b ₂ ≈	b ₃ ≈	b ₄ ≈	d ₂	d ₃ ≈	d ₄	h ₁	h ₂	h ₃	h ₄	i	l ₁ ≈	m ₃ ≈	m ₄	n ₁	n ₂	n ₃ ≈	n ₄	s ₂	w	x	
80-160/154 ⁴⁾	90L	x		100	80	125	153	192		200	190		160	225	168		118	589				225	130				156	140
80-160/224 ⁴⁾	100L	x		100	80	125	153	192		250	213		160	225	168		118	642				225	130				170	140
80-160/304 ⁴⁾	100L	x		100	80	125	153	192		250	213		160	225	168		118	677				225	130				170	140
80-160/404 ⁴⁾	112M	x	x	100	80	125	153	192		250	234		160	225	168		118	666				225	130				170	140
80-160/554 ^{3/4)}	132S		x	100	80	125	153	192	55	300	266	12		225	168	132	282	731	220	140				270	216	15	193	140
80-200/224	100L	x		100	80	125	161	189		250	213		180	250	170		142	662				260	180				190	140
80-200/304	100L	x		100	80	125	161	189		250	213		180	250	170		142	697				260	180				190	140
80-200/404	112M	x		100	80	125	161	189		250	234		180	250	170		142	686				260	180				190	140
80-200/554 ^{3/4)}	132S	x	x	100	80	125	161	189	55	300	266	12		250	170	132	302	751	220	140				270	216	15	213	140
80-200/754 ^{3/4)}	132M		x	100	80	125	161	189	59	300	298	12		250	170	132	302	779	240	178				270	216	15	213	140
80-200/1104 ^{3/4)}	160M		x	100	80	125	161	189	70	350	325	15		250	170	160	354	917	300	210				320	254	21	246	140
80-250/404 ⁴⁾	112M	x		100	80	125	184	210		250	234		180	280	195		142	686				260	180				190	140
80-250/554 ^{3/4)}	132S	x		100	80	125	184	210	55	300	266	12		280	195	132	302	751	220	140				270	216	15	213	140
80-250/754 ^{3/4)}	132M	x	x	100	80	125	184	210	59	300	298	12		280	195	132	302	779	240	178				270	216	15	213	140
80-250/1104 ^{3/4)}	160M	x	x	100	80	125	184	210	70	350	325	15		280	195	160	354	917	300	210				320	254	21	246	140
80-250/1504 ^{3/4)}	160L		x	100	80	125	184	210	70	350	325	15		280	195	160	354	923	314	254				320	254	21	246	140
80-250/1854 ⁴⁾	180M		x	100	80	125	184	210	80	350	370	15		280	195	180	367	981	320	241				360	279	23	246	140
80-315/754 ^{3/4)}	132M	x		100	80	125	220	244	59	300	298	12		315	228	132	302	779	240	178				270	216	15	213	140
80-315/1104 ^{3/4)}	160M	x		100	80	125	220	244	70	350	325	15		315	228	160	354	917	300	210				320	254	21	246	140
80-315/1504 ^{3/4)}	160L	x	x	100	80	125	220	244	70	350	325	15		315	228	160	354	923	314	254				320	254	21	246	140
80-315/1854 ⁴⁾	180M	x	x	100	80	125	220	244	80	350	370	15		315	228	180	367	923	320	241				360	279	23	246	140
80-315/2204 ⁴⁾	180L	x	x	100	80	125	220	244	80	350	370	15		315	228	180	367	981	358	279				360	279	23	246	140
100-160/304 ⁴⁾	100L	x		125	100	125	178	225		250	213		180	280	196		142	697				260	180				190	140
100-160/404 ⁴⁾	112M	x		125	100	125	178	225		250	234		180	280	196		142	686				260	180				190	140
100-160/554 ^{3/4)}	132S	x	x	125	100	125	178	225	55	300	266	12		280	196	132	302	751	220	140				270	216	15	213	140
100-160/754 ^{3/4)}	132M	x	x	125	100	125	178	225	59	300	298	12		280	196	132	302	779	240	178				270	216	15	213	140
100-200/404 ⁴⁾	112M	x		125	100	125	173	213		250	234		180	280	190		0	686				260	180				190	140
100-200/554 ^{3/4)}	132S	x		125	100	125	173	213	55	300	266	12		280	190	132	302	751	220	140				270	216	15	213	140
100-200/754 ^{3/4)}	132M	x	x	125	100	125	173	213	59	300	298	12		280	190	132	302	779	240	178				270	216	15	213	140
100-200/1104 ^{3/4)}	160M		x	125	100	125	173	213	70	350	325	15		280	190	160	354	917	300	210				320	254	21	246	140
100-200/1504 ^{3/4)}	160L		x	125	100	125	173	213	70	350	325	15		280	190	160	354	923	314	254				320	254	21	246	140
100-250/754 ^{3/4)}	132M	x		125	100	140	190	220	59	300	298	12		280	201	132	302	794	240	178				270	216	15	213	140
100-250/1104 ^{3/4)}	160M	x	x	125	100	140	190	220	70	350	325	15		280	201	160	354	932	300	210				320	254	21	246	140
100-250/1504 ^{3/4)}	160L	x	x	125	100	140	190	220	70	350	325	15		280	201	160	354	938	314	254				320	254	21	246	140
100-250/1854 ⁴⁾	180M		x	125	100	140	190	220	80	350	370	15		280	201	180	367	996	320	241				360	279	23	246	140
100-250/2204 ⁴⁾	180L		x	125	100	140	190	220	80	350	370	15		280	201	180	367	996	358	279				360	279	23	246	140

1) Rc = ISO 7/1; G = ISO 228/1
 2) DN = EN 1092-2/DN₁/PN 16/21/JL1040/B
 DN 200 = EN 1092-2/DN 200/PN 10/21/JL1040/B
 3) bei diesen Baugrößen sind die Motorfüße 20 mm zu unterbauen
 4) Δ h₃ ≥ h₁ / h₃ ≥ h₄
 the motor feet of these sizes are to be underpinned by 20 mm thick shims
 Il faut appuyer les pieds de moteur de ces tailles de construction avec des feuillets de 20 mm
 Con queste grandezze sotto i piedi del motore si devono sistemare degli spessori da 20 mm
 Bij deze grootten dienen de motorvoeten 20 mm opgevuuld te worden

Etabloc GN, MN 100-315/... bis 150-250/..., n = 1450 1/min, n = 1750 1/min

mit Stützfuß (bis Motorbaugröße 112 = 4 kW)
 mit Motorfuß (ab Motorbaugröße 132 = 5,5 kW)
 with support foot (up to motor size 112 = 4 kW)
 with motor foot (motor size 132 = 5.5 kW and above)
 avec béquille (jusqu'à taille de moteur 112 = 4 kW)

avec pied de moteur (à partir de la taille de moteur 132 = 5,5 kW)
 con piede angolare (fino alla grandezza del motore 112 = 4 kW)
 con piede di fusione (a partire della grandezza del motore 132 = 5,5 kW)
 met voetsteun (tot motorgrootte 112 = 4 kW)
 met motorvoet (vanaf motorgrootte 132 = 5,5 kW)

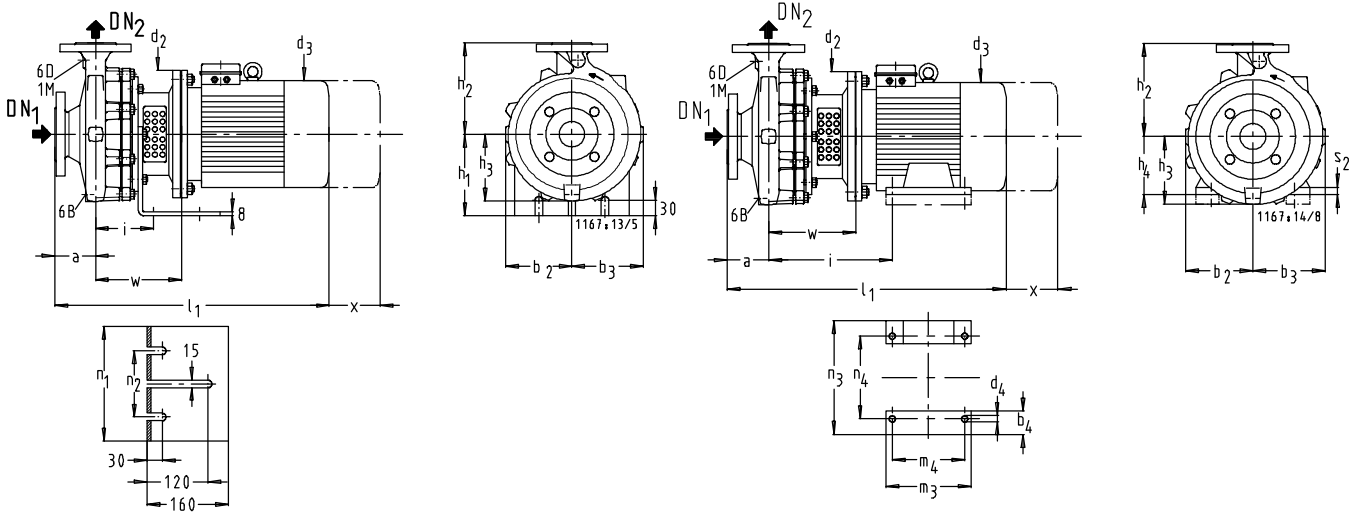

		Etabloc G, M Etabloc GN, MN, BN		Etabloc SN, CN	
		DN ₂ 32 - DN ₂ 80	DN ₂ 100	DN ₂ 32 - DN ₂ 80	DN ₂ 100 - DN ₂ 150
1 M	Druckmessgerät-Anschluss / Pressure gauge connection / Indicateur de pression / Manomètre / Manometro / Manometer	Rc 3/8 ¹⁾	Rc 1/2 ¹⁾	G 3/8 ¹⁾	G 1/2 ¹⁾
6 B	Förderflüssigkeit-Entleerung / Casing drain / Vidange du liquide pompé / Scarico del liquido convogliato / Vloeistof- aftap	Rc 3/8 ¹⁾	Rc 1/2 ¹⁾	G 3/8 ¹⁾	G 1/2 ¹⁾
6 D	Förderflüssigkeit-Auffüllen und Entlüften / Filling and venting of medium handled / Remplissage et purge d'air du liquide pompé / Riempimento del liquido convogliato spurgo dell'aria / Vloeistof vullen en ontluften	Rc 3/8 ¹⁾	Rc 1/2 ¹⁾	G 3/8 ¹⁾	G 1/2 ¹⁾

mm

Etabloc GN, MN	M	n= 1450	n= 1750	Toleranz der Anschlussmaße nach EN 735																								
				DN ₁ 2)	DN ₂ 2)	a	b ₂ ≈	b ₃ ≈	b ₄ ≈	d ₂	d ₃ ≈	d ₄	h ₁	h ₂	h ₃	h ₄	i	l ₁ ≈	m ₃ ≈	m ₄	n ₁	n ₂	n ₃ ≈	n ₄	s ₂	w	x	
100-315/1504 ^{3/4)}	160L	x		125	100	140	225	255	70	350	325	15	315	237	160	354	938	314	254					320	254	21	246	140
100-315/1854 ⁴⁾	180M	x	x	125	100	140	225	255	80	350	370	15	315	237	180	367	996	320	241					360	279	23	246	140
100-315/2204 ⁴⁾	180L	x	x	125	100	140	225	255	80	350	370	15	315	237	180	367	996	358	279					360	279	23	246	140
125-200/754 ^{3/4)}	132M	x		150	125	140	195	244	59	300	298	12	315	216	132	302	794	240	178					270	216	15	213	140
125-200/1104 ^{3/4)}	160M	x	x	150	125	140	195	244	70	350	325	15	315	216	160	354	932	300	210					320	254	21	246	140
125-200/1504 ^{3/4)}	160L	x	x	150	125	140	195	244	70	350	325	15	315	216	160	354	938	314	254					320	254	21	246	140
125-200/1854 ⁴⁾	180M		x	150	125	140	195	244	80	350	370	15	315	216	180	367	996	320	241					360	279	23	246	140
125-200/2204 ⁴⁾	180L		x	150	125	140	195	244	80	350	370	15	315	216	180	367	996	358	279					360	279	23	246	140
125-250/1104 ^{3/4)}	160M	x		150	125	140	226	275	70	350	325	15	315	245	160	354	932	300	210					320	254	21	246	140
125-250/1504 ^{3/4)}	160L	x	x	150	125	140	226	275	70	350	325	15	315	245	160	354	938	314	254					320	254	21	246	140
125-250/1854 ⁴⁾	180M	x	x	150	125	140	226	275	80	350	370	15	315	245	180	367	996	320	241					360	279	23	246	140
125-250/2204 ⁴⁾	180L	x	x	150	125	140	226	275	80	350	370	15	315	245	180	367	996	358	279					360	279	23	246	140
150-200/754 ^{3/4)}	132M	x		200	150	160	238	315	59	300	298	12	400	275	132	302	814	240	178					270	216	15	213	140
150-200/1104 ^{3/4)}	160M	x		200	150	160	238	315	70	350	325	15	400	275	160	354	952	300	210					320	254	21	246	140
150-200/1504 ^{3/4)}	160L	x	x	200	150	160	238	315	70	350	325	15	400	275	160	354	958	314	254					320	254	21	246	140
150-200/1854 ⁴⁾	180M		x	200	150	160	238	315	80	350	370	15	400	275	180	367	1016	320	241					360	279	23	246	140
150-200/2204 ⁴⁾	180L		x	200	150	160	238	315	80	350	370	15	400	275	180	367	1016	358	279					360	279	23	246	140
150-250/1504 ^{3/4)}	160L	x		200	150	160	228	298	70	350	325	15	400	260	160	354	958	314	254					320	254	21	246	140
150-250/1854 ⁴⁾	180M	x		200	150	160	228	298	80	350	370	15	400	260	180	367	1016	320	241					360	279	23	246	140
150-250/2204 ⁴⁾	180L	x	x	200	150	160	228	298	80	350	370	15	400	260	180	367	1016	358	279					360	279	23	246	140

 1) Rc = ISO 7/1;
 G = ISO 228/1

 2) DN = EN 1092-2/DN../PN 16/21/JL1040/B
 DN 200 = EN 1092-2/DN 200/PN 10/21/JL1040/B

3) bei diesen Baugrößen sind die Motorfüße 20 mm zu unterbauen

3) the motor feet of these sizes are to be underpinned by 20 mm thick shims

3) Il faut appuyer les pieds de moteur de ces tailles de construction avec des feuillets de 20 mm

3) Con queste grandezze sotto i piedi del motore si devono sistemare degli spessori da 20 mm

3) Bij deze grootten dienen de motorvoeten 20 mm opgevuld te worden

 4) $h_3 \geq h_1 / h_3 \geq h_4$

Etabloc BN, SN, CN 32-125.1/... bis 32-125/..., n = 2900 1/min, n = 3500 1/min

ohne Motorfuß (bis Motorbaugröße 112 = 4 kW)
 mit Motorfuß (ab Motorbaugröße 132 = 5,5 kW)
 without motor foot (up to motor size 112 = 4 kW)
 with motor foot (motor size 132 = 5,5 kW and above)
 sans pied de moteur (jusqu'à taille de moteur 112 = 4 kW)

avec pied de moteur (à partir de la taille de moteur 132 = 5,5 kW)
 senza piede di fusione (fino alla grandezza del motore 112 = 4 kW)
 con piede di fusione (a partire della grandezza del motore 132 = 5,5 kW)
 zonder motorvoet (tot motorgrootte 112 = 4 kW)
 met motorvoet (vanaf motorgrootte 132 = 5,5 kW)

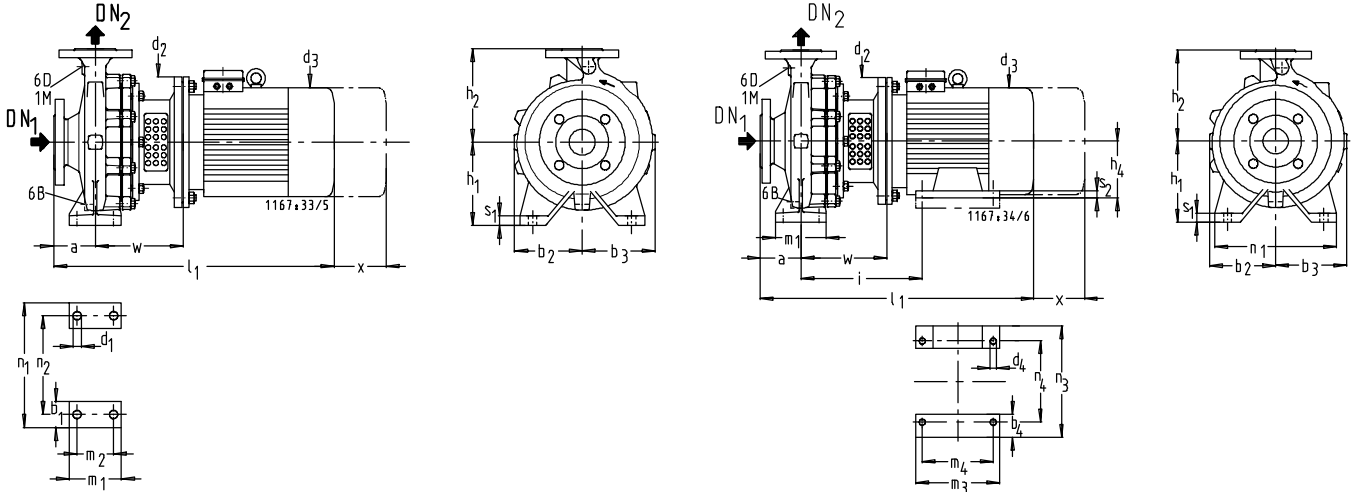

		Etabloc G, M		Etabloc SN, CN	
		Etabloc GN, MN, BN		DN ₂ 32 - DN ₂ 80	DN ₂ 100 - DN ₂ 150
1 M	Druckmessgerät-Anschluss / Pressure gauge connection / Indicateur de pression / Manomètre / Manometro / Manometer	Rc 3/8 ¹⁾	Rc 1/2 ¹⁾	G 3/8 ¹⁾	G 1/2 ¹⁾
6 B	Förderflüssigkeit-Entleerung / Casing drain / Vidange du liquide pompé / Scarico del liquido convogliato / Vloeistof- aftap	Rc 3/8 ¹⁾	Rc 1/2 ¹⁾	G 3/8 ¹⁾	G 1/2 ¹⁾
6 D	Förderflüssigkeit-Auffüllen und Entlüften / Filling and venting of medium handled / Remplissage et purge d'air du liquide pompé / Riempimento del liquido convogliato spurgo dell'aria / Vloeistof vullen en ontluften	Rc 3/8 ¹⁾	Rc 1/2 ¹⁾	G 3/8 ¹⁾	G 1/2 ¹⁾

Etabloc BN, SN, CN	Ⓜ	n = 2900	n = 3500	Toleranz der Anschlussmaße nach EN 735																											
				DN ₁ 2)	DN ₂ 2)	a	b ₁	b ₂	b ₃ ≈	b ₄ ≈	d ₁	d ₂	d ₃ ≈	d ₄	h ₁	h ₂	h ₄	i	l ₁ ≈	m ₁ ≈	m ₂	m ₃ ≈	m ₄	n ₁	n ₂	n ₃ ≈	n ₄	s ₁	s ₂	w	x
32-125.1/072	80	x		50	32	80	50	113	113	14	200	162	112	140				491	100	70			190	140			15		156	100	
32-125.1/112	80	x	x	50	32	80	50	113	113	14	200	162	112	140				505	100	70			190	140			15		156	100	
32-125.1/152	90S	x	x	50	32	80	50	113	113	14	200	190	112	140				518	100	70			190	140			15		156	100	
32-125.1/222	90L	x	x	50	32	80	50	113	113	14	200	190	112	140				544	100	70			190	140			15		156	100	
32-125.1/302	100L		x	50	32	80	50	113	113	14	250	213	112	140				597	100	70			190	140			15		170	100	
32-125.1/402	112M		x	50	32	80	50	113	113	14	250	234	112	140				621	100	70			190	140			15		170	100	
32-125.1/552 ³⁾	132S		x	50	32	80	50	113	113	55	14	300	266	12	112	140	132	282	686	100	70	220	140	190	140	270	216	15	15	193	100
32-160.1/152	90S	x		50	32	80	50	116	125	14	200	190	132	160				518	100	70			240	190			15		156	100	
32-160.1/222	90L	x	x	50	32	80	50	116	125	14	200	190	132	160				544	100	70			240	190			15		156	100	
32-160.1/302	100L	x	x	50	32	80	50	116	125	14	250	213	132	160				597	100	70			240	190			15		170	100	
32-160.1/402	112M	x	x	50	32	80	50	116	125	14	250	234	132	160				621	100	70			240	190			15		170	100	
32-160.1/552 ³⁾	132S		x	50	32	80	50	116	125	55	14	300	266	12	132	160	132	282	686	100	70	220	140	240	190	270	216	15	15	193	100
32-160.1/752 ³⁾	132S		x	50	32	80	50	116	125	55	14	300	266	12	132	160	132	282	686	100	70	220	140	240	190	270	216	15	15	193	100
32-200.1/302	100L	x		50	32	80	50	128	137	14	250	213	160	180				597	100	70			240	190			18		170	100	
32-200.1/402	112M	x	x	50	32	80	50	128	137	14	250	234	160	180				621	100	70			240	190			18		170	100	
32-200.1/552 ³⁾	132S	x	x	50	32	80	50	128	137	55	14	300	266	12	160	180	132	282	686	100	70	220	140	240	190	270	216	18	15	193	100
32-200.1/752 ³⁾	132S		x	50	32	80	50	128	137	55	14	300	266	12	160	180	132	282	686	100	70	220	140	240	190	270	216	18	15	193	100
32-200.1/1102 ³⁾	160M		x	50	32	80	50	128	137	70	14	350	325	15	160	180	160	334	852	100	70	300	210	240	190	320	254	18	21	226	100
32-200.1/1502 ³⁾	160M		x	50	32	80	50	128	137	70	14	350	325	15	160	180	160	334	852	100	70	300	210	240	190	320	254	18	21	226	100
32-250.1/552 ³⁾	132S	x		50	32	100	65	164	171	55	14	300	266	12	180	225	132	282	706	125	95	220	140	320	250	270	216	18	15	193	100
32-250.1/752 ³⁾	132S	x		50	32	100	65	164	171	55	14	300	266	12	180	225	132	282	706	125	95	220	140	320	250	270	216	18	15	193	100
32-250.1/1102 ³⁾	160M	x		50	32	100	65	164	171	70	14	350	325	15	180	225	160	334	872	125	95	300	210	320	250	320	254	18	21	226	100
32-250.1/1502 ³⁾	160M	x		50	32	100	65	164	171	70	14	350	325	15	180	225	160	334	872	125	95	300	210	320	250	320	254	18	21	226	100
32-125/112	80	x		50	32	80	50	113	113	14	200	162	112	140				505	100	70			190	140			15		156	100	
32-125/152	90S	x	x	50	32	80	50	113	113	14	200	190	112	140				518	100	70			190	140			15		156	100	
32-125/222	90L	x	x	50	32	80	50	113	113	14	200	190	112	140				544	100	70			190	140			15		156	100	
32-125/302	100L	x	x	50	32	80	50	113	113	14	250	213	112	140				597	100	70			190	140			15		170	100	
32-125/402	112M		x	50	32	80	50	113	113	14	250	234	112	140				621	100	70			190	140			15		170	100	
32-125/552 ³⁾	132S		x	50	32	80	50	113	113	55	14	300	266	12	112	140	132	282	686	100	70	220	140	190	140	270	216	15	15	193	100

- 1) Rc = ISO 7/1; G = ISO 228/1 2) Etabloc BN: DN=ISO 7005-3/DN.../PN10/21; Etabloc SN: DN=EN 1092-2/DN.../PN16/21/JS1025/B; Etabloc CN: DN=EN 1092-1/DN.../PN16/21/B
- 3) bei diesen Baugrößen sind die Motorfüße 20 mm zu unterbauen
 3) the motor feet of these sizes are to be underpinned by 20 mm thick shims
 3) Il faut appuyer les pieds de moteur de ces tailles de construction avec des feuillets de 20 mm
 3) Con queste grandezze sotto i piedi del motore si devono sistemare degli spessori di 20 mm (mm5)
 3) Bij deze grootten dienen de motorvoeten 20 mm opgevuuld te worden
- 4) $h_1 \geq h_4$
- 5) Flansche DN₁ 65 / DN₂ 65 4 Loch
 5) Flanges DN₁ 65 / DN₂ 65 4-hole
 5) Brides DN₁ 65 / DN₂ 65 4 trous
 5) Bridas DN₁ 65 / DN₂ 65 4 taladro
 5) Flens DN₁ 65 / DN₂ 65 vier gaten

Etabloc BN, SN, CN 32-160/... bis 40-160/..., n = 2900 1/min, n = 3500 1/min

ohne Motorfuß (bis Motorbaugröße 112 = 4 kW)
 mit Motorfuß (ab Motorbaugröße 132 = 5,5 kW)
 without motor foot (up to motor size 112 = 4 kW)
 with motor foot (motor size 132 = 5,5 kW and above)
 sans pied de moteur (jusqu'à taille de moteur 112 = 4 kW)

avec pied de moteur (à partir de la taille de moteur 132 = 5,5 kW)
 senza piede di fusione (fino alla grandezza del motore 112 = 4 kW)
 con piede di fusione (a partire della grandezza del motore 132 = 5,5 kW)
 zonder motorvoet (tot motorgrootte 112 = 4 kW)
 met motorvoet (vanaf motorgrootte 132 = 5,5 kW)

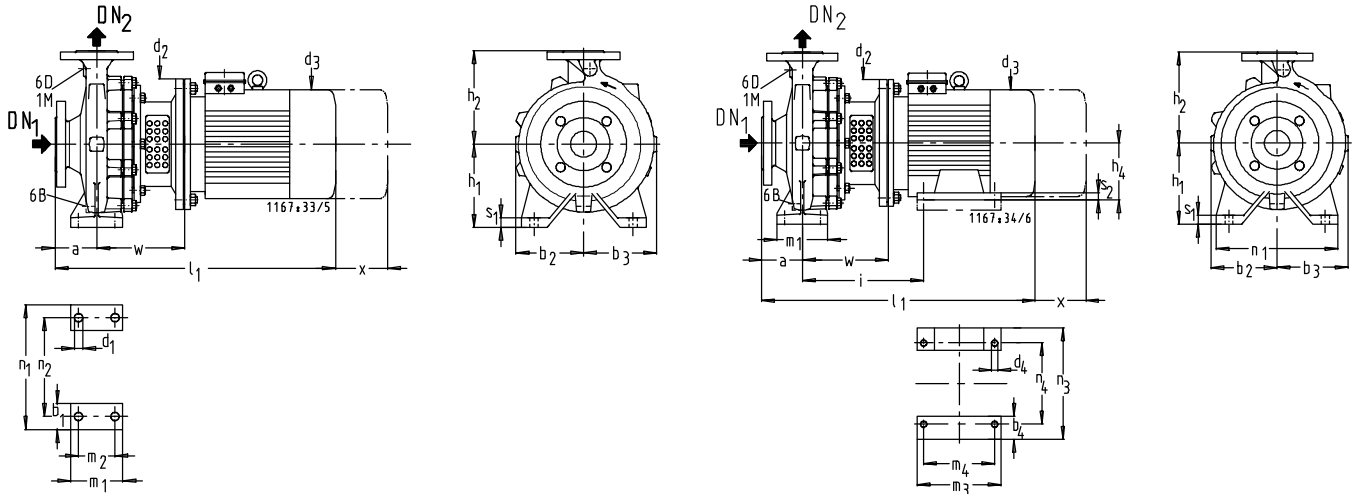

		Etabloc G, M Etabloc GN, MN, BN		Etabloc SN, CN			
		DN ₂ 32 - DN ₂ 80		DN ₂ 32 - DN ₂ 80		DN ₂ 100 - DN ₂ 150	
1 M	Druckmessgerät-Anschluss / Pressure gauge connection / Indicateur de pression / Manomètre / Manometro / Manometer	Rc 3/8 ¹⁾	Rc 1/2 ¹⁾	G 3/8 ¹⁾	G 1/2 ¹⁾		
6 B	Förderflüssigkeit-Entleerung / Casing drain / Vidange du liquide pompé / Scarico del liquido convogliato / Vloeistof- aftap	Rc 3/8 ¹⁾	Rc 1/2 ¹⁾	G 3/8 ¹⁾	G 1/2 ¹⁾		
6 D	Förderflüssigkeit-Auffüllen und Entlüften / Filling and venting of medium handled / Remplissage et purge d'air du liquide pompé / Riempimento del liquido convogliato spurgo dell'aria / Vloeistof vullen en ontluften	Rc 3/8 ¹⁾	Rc 1/2 ¹⁾	G 3/8 ¹⁾	G 1/2 ¹⁾		

Etabloc BN, SN, CN	M	n = 2900	n = 3500	Toleranz der Anschlussmaße nach EN 735																											
				DN ₁ 2)	DN ₂ 2)	a	b ₁ ≈	b ₂ ≈	b ₃ ≈	b ₄ ≈	d ₁	d ₂	d ₃ ≈	d ₄	h ₁	h ₂	h ₄	i	l ₁ ≈	m ₁	m ₂	m ₃ ≈	m ₄	n ₁	n ₂	n ₃ ≈	n ₄	s ₁	s ₂	w	x
32-160/222	90L	x		50	32	80	50	113	125		14	200	190	132	160			544	100	70			240	190			15	15	156	100	
32-160/302	100L	x	x	50	32	80	50	113	125		14	250	213	132	160			597	100	70			240	190			15	15	170	100	
32-160/402	112M	x	x	50	32	80	50	113	125		14	250	234	132	160			621	100	70			240	190			15	15	170	100	
32-160/552 ³⁾⁴⁾	132S		x	50	32	80	50	113	125	55	14	300	266	12	132	160	132	282	686	100	70	220	140	240	190	270	216	15	15	193	100
32-160/752 ³⁾⁴⁾	132S		x	50	32	80	50	113	125	55	14	300	266	12	132	160	132	282	686	100	70	220	140	240	190	270	216	15	15	193	100
32-200/402	112M	x		50	32	80	50	132	141		14	250	234		160	180			621	100	70			240	190			18	18	170	100
32-200/552 ³⁾⁴⁾	132S	x	x	50	32	80	50	132	141	55	14	300	266	12	160	180	132	282	686	100	70	220	140	240	190	270	216	18	15	193	100
32-200/752 ³⁾⁴⁾	132S	x	x	50	32	80	50	132	141	55	14	300	266	12	160	180	132	282	686	100	70	220	140	240	190	270	216	18	15	193	100
32-200/1102 ³⁾⁴⁾	160M	x	x	50	32	80	50	132	141	70	14	350	325	15	160	180	160	334	852	100	70	300	210	240	190	320	254	18	21	226	100
32-200/1502 ³⁾⁴⁾	160M		x	50	32	80	50	132	141	70	14	350	325	15	160	180	160	334	852	100	70	300	210	240	190	320	254	18	21	226	100
32-250/752 ³⁾⁴⁾	132S	x		50	32	100	65	170	176	55	14	300	266	12	180	225	132	282	706	125	95	220	140	320	250	270	216	18	15	193	100
32-250/1102 ³⁾⁴⁾	160M	x		50	32	100	65	170	176	70	14	350	325	15	180	225	160	334	872	125	95	300	210	320	250	320	254	18	21	226	100
32-250/1502 ³⁾⁴⁾	160M	x		50	32	100	65	170	176	70	14	350	325	15	180	225	160	334	872	125	95	300	210	320	250	320	254	18	21	226	100
40-125/152	90S	x		65 ⁵⁾	40	80	50	113	113		14	200	190		112	140			518	100	70			210	160			15	15	156	100
40-125/222	90L	x	x	65 ⁵⁾	40	80	50	113	113		14	200	190		112	140			544	100	70			210	160			15	15	156	100
40-125/302	100L	x	x	65 ⁵⁾	40	80	50	113	113		14	250	213		112	140			597	100	70			210	160			15	15	170	100
40-125/402	112M	x	x	65 ⁵⁾	40	80	50	113	113		14	250	234		112	140			621	100	70			210	160			15	15	170	100
40-125/552 ³⁾	132S		x	65 ⁵⁾	40	80	50	113	113	55	14	300	266	12	112	140	132	282	686	100	70	220	140	210	160	270	216	15	15	193	100
40-125/752 ³⁾	132S		x	65 ⁵⁾	40	80	50	113	113	55	14	300	266	12	112	140	132	282	686	100	70	220	140	210	160	270	216	15	15	193	100
40-125/1102 ³⁾	160M		x	65 ⁵⁾	40	80	50	113	113	70	14	350	325	15	112	140	160	334	852	100	70	300	210	210	160	320	254	15	21	226	100
40-160/302	100L	x		65 ⁵⁾	40	80	50	115	131		14	250	213		132	160			597	100	70			240	190			15	15	170	100
40-160/402	112M	x	x	65 ⁵⁾	40	80	50	115	131		14	250	234		132	160			621	100	70			240	190			15	15	170	100
40-160/552 ³⁾⁴⁾	132S	x	x	65 ⁵⁾	40	80	50	115	131	55	14	300	266	12	132	160	132	282	686	100	70	220	140	240	190	270	216	15	15	193	100
40-160/752 ³⁾⁴⁾	132S	x	x	65 ⁵⁾	40	80	50	115	131	55	14	300	266	12	132	160	132	282	686	100	70	220	140	240	190	270	216	15	15	193	100
40-160/1102 ³⁾	160M	x	x	65 ⁵⁾	40	80	50	115	131	70	14	350	325	15	132	160	160	334	852	100	70	300	210	240	190	320	254	15	21	226	100
40-160/1502 ³⁾	160M		x	65 ⁵⁾	40	80	50	115	131	70	14	350	325	15	132	160	160	334	852	100	70	300	210	240	190	320	254	15	21	226	100

- 1) Rc = ISO 7/1; G = ISO 228/1 2) Etabloc BN: DN=ISO 7005-3/DN.../PN10/21; Etabloc SN: DN=EN 1092-2/DN.../PN16/21/JS1025/B; Etabloc CN: DN=EN 1092-1/DN.../PN16/21/B
- 3) bei diesen Baugrößen sind die Motorfüße 20 mm zu unterbauen
 3) the motor feet of these sizes are to be underpinned by 20 mm thick shims
 3) Il faut appuyer les pieds de moteur de ces tailles de construction avec des feuillets de 20 mm
 3) Con queste grandezze sotto i piedi del motore si devono sistemare degli spessori di 20 mm
 3) Bij deze grootten dienen de motorvoeten 20 mm opgevuld te worden
- 4) h₁ ≥ h₄
- 5) Flansche DN₁ 65 / DN₂ 65 4 Loch
 5) Flanges DN₁ 65 / DN₂ 65 4-hole
 5) Brides DN₁ 65 / DN₂ 65 4 trous
 5) Bridas DN₁ 65 / DN₂ 65 4 taladro
 5) Flens DN₁ 65 / DN₂ 65 vier gaten

Etabloc BN, SN, CN 40-200/... bis 50-250/..., n = 2900 1/min, n = 3500 1/min

ohne Motorfuß (bis Motorbaugröße 112 = 4 kW)
 mit Motorfuß (ab Motorbaugröße 132 = 5,5 kW)
 without motor foot (up to motor size 112 = 4 kW)
 with motor foot (motor size 132 = 5,5 kW and above)
 sans pied de moteur (jusqu'à taille de moteur 112 = 4 kW)

avec pied de moteur (à partir de la taille de moteur 132 = 5,5 kW)
 senza piede di fusione (fino alla grandezza del motore 112 = 4 kW)
 con piede di fusione (a partire della grandezza del motore 132 = 5,5 kW)
 zonder motorvoet (tot motorgrootte 112 = 4 kW)
 met motorvoet (vanaf motorgrootte 132 = 5,5 kW)

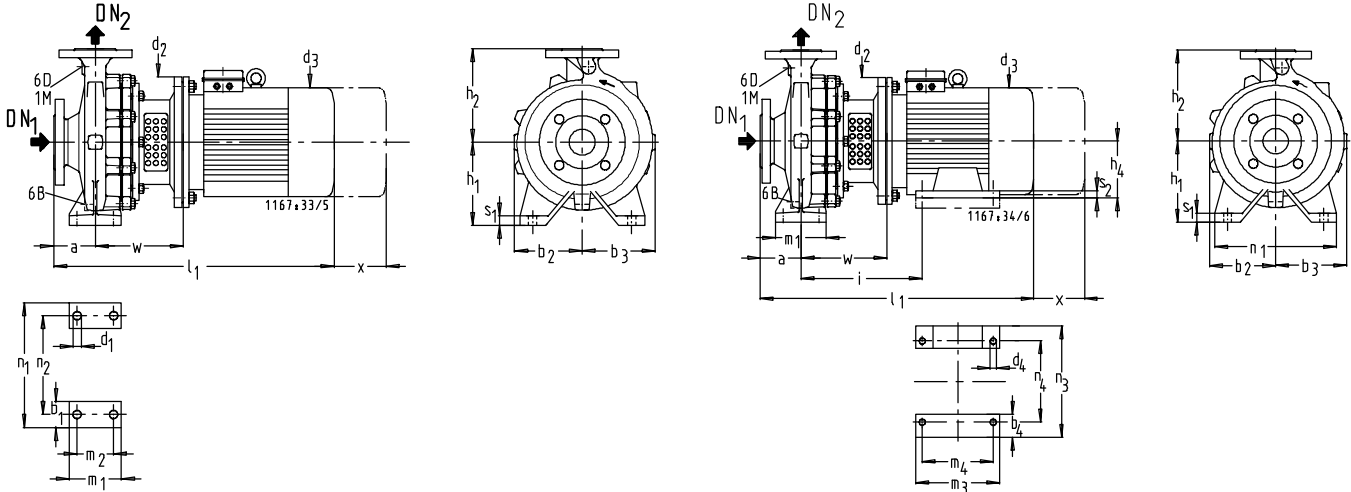

		Etabloc G, M Etabloc GN, MN, BN		Etabloc SN, CN			
		DN ₂ 32 - DN ₂ 80	DN ₂ 100	DN ₂ 32 - DN ₂ 80	DN ₂ 100 - DN ₂ 150		
1 M	Druckmessgerät-Anschluss / Pressure gauge connection / Indicateur de pression / Manomètre / Manometro / Manometer	Rc 3/8 1)	Rc 1/2 1)	G 3/8 1)	G 1/2 1)		
6 B	Förderflüssigkeit-Entleerung / Casing drain / Vidange du liquide pompé / Scarico del liquido convogliato / Vloeistof- aftap	Rc 3/8 1)	Rc 1/2 1)	G 3/8 1)	G 1/2 1)		
6 D	Förderflüssigkeit-Auffüllen und Entlüften / Filling and venting of medium handled / Remplissage et purge d'air du liquide pompé / Riempimento del liquido convogliato spurgo dell'aria / Vloeistof vullen en ontluften	Rc 3/8 1)	Rc 1/2 1)	G 3/8 1)	G 1/2 1)		

mm

Etabloc BN, SN, CN	Ⓜ	n = 2900	n = 3500	Toleranz der Anschlussmaße nach EN 735																											
				DN ₁ 2)	DN ₂ 2)	a	b ₁ ≈	b ₂ ≈	b ₃ ≈	b ₄ ≈	d ₁	d ₂	d ₃ ≈	d ₄	h ₁	h ₂	h ₄	i	l ₁ ≈	m ₁	m ₂	m ₃ ≈	m ₄	n ₁	n ₂	n ₃ ≈	n ₄	s ₁	s ₂	w	x
40-200/552 3/4)	132S	x		65 3)	40	100	50	140	152	55	14	300	266	12	160	180	132	282	706	100	70	220	140	265	212	270	216	18	15	193	100
40-200/752 3/4)	132S	x	x	65 3)	40	100	50	140	152	55	14	300	266	12	160	180	132	282	706	100	70	220	140	265	212	270	216	18	15	193	100
40-200/1102 3/4)	160M	x	x	65 3)	40	100	50	140	152	70	14	350	325	15	160	180	160	334	872	100	70	300	210	265	212	320	254	18	21	226	100
40-200/1502 3/4)	160M	x	x	65 3)	40	100	50	140	152	70	14	350	325	15	160	180	160	334	872	100	70	300	210	265	212	320	254	18	21	226	100
40-200/1852 3/4)	160L		x	65 3)	40	100	50	140	152	70	14	350	325	15	160	180	160	334	878	100	70	314	254	265	212	320	254	18	21	226	100
40-200/2202	180M		x	65 3)	40	100	50	140	152	80	14	350	370	15	160	180	180	347	936	100	70	320	241	265	212	360	279	18	23	226	100
40-250/1102	160M	x		65 3)	40	100	65	165	178	70	14	350	325	15	180	225	160	334	872	125	95	300	210	320	250	320	254	18	21	226	100
40-250/1502	160M	x		65 3)	40	100	65	165	178	70	14	350	325	15	180	225	160	334	872	125	95	300	210	320	250	320	254	18	21	226	100
40-250/1852	160L	x		65 3)	40	100	65	165	178	70	14	350	325	15	180	225	160	334	878	125	95	314	254	320	250	320	254	18	21	226	100
40-250/2202	180M	x		65 3)	40	100	65	165	178	80	14	350	370	15	180	225	180	347	936	125	95	320	241	320	250	360	279	18	23	226	100
50-125/302	100L	x		65 3)	50	100	50	113	128		14	250	213		132	160			617	100	70				240	190			170	100	
50-125/402	112M	x		65 3)	50	100	50	113	128		14	250	234		132	160			641	100	70				240	190			170	100	
50-125/552 3/4)	132S	x	x	65 3)	50	100	50	113	128	55	14	300	266	12	132	160	132	282	706	100	70	220	140	240	190	270	216	18	15	193	100
50-125/752 3/4)	132S	x	x	65 3)	50	100	50	113	128	55	14	300	266	12	132	160	132	282	706	100	70	220	140	240	190	270	216	18	15	193	100
50-125/1102 3)	160M		x	65 3)	50	100	50	113	128	70	14	350	325	15	132	160	160	334	872	100	70	300	210	240	190	320	254	18	21	226	100
50-125/1502 3)	160M		x	65 3)	50	100	50	113	128	70	14	350	325	15	132	160	160	334	872	100	70	300	210	240	190	320	254	18	21	226	100
50-160/552 3/4)	132S	x	x	65 3)	50	100	50	126	147	55	14	300	266	12	160	180	132	282	706	100	70	220	140	265	212	270	216	18	15	193	100
50-160/752 3/4)	132S	x	x	65 3)	50	100	50	126	147	55	14	300	266	12	160	180	132	282	706	100	70	220	140	265	212	270	216	18	15	193	100
50-160/1102 3/4)	160M	x	x	65 3)	50	100	50	126	147	70	14	350	325	15	160	180	160	334	872	100	70	300	210	265	212	320	254	18	21	226	100
50-160/1502 3/4)	160M	x	x	65 3)	50	100	50	126	147	70	14	350	325	15	160	180	160	334	872	100	70	300	210	265	212	320	254	18	21	226	100
50-160/1852 3/4)	160L		x	65 3)	50	100	50	126	147	70	14	350	325	15	160	180	160	334	878	100	70	314	254	265	212	320	254	18	21	226	100
50-160/2202	180M		x	65 3)	50	100	50	126	147	80	14	350	370	15	160	180	180	347	936	100	70	320	241	265	212	360	279	18	23	226	100
50-200/1102 3/4)	160M	x	x	65 3)	50	100	50	145	165	70	14	350	325	15	160	200	160	334	872	100	70	300	210	265	212	320	254	18	21	226	100
50-200/1502 3/4)	160M	x	x	65 3)	50	100	50	145	165	70	14	350	325	15	160	200	160	334	872	100	70	300	210	265	212	320	254	18	21	226	100
50-200/1852 3/4)	160L	x	x	65 3)	50	100	50	145	165	70	14	350	325	15	160	200	160	334	878	100	70	314	254	265	212	320	254	18	21	226	100
50-200/2202	180M	x	x	65 3)	50	100	50	145	165	80	14	350	370	15	160	200	180	347	936	100	70	320	241	265	212	360	279	18	23	226	100
50-250/1502 3/4)	160M	x		65 3)	50	100	65	168	184	70	14	350	325	15	180	225	160	334	872	125	95	300	210	320	250	320	254	18	21	226	100
50-250/1852 3/4)	160L	x		65 3)	50	100	65	168	184	70	14	350	325	15	180	225	160	334	878	125	95	314	254	320	250	320	254	18	21	226	100
50-250/2202 4)	180M	x		65 3)	50	100	65	168	184	80	14	350	370	15	180	225	180	347	936	125	95	320	241	320	250	360	279	18	23	226	100
50-250/3002	200L	x		65 3)	50	100	65	168	184	85	14	400	422	19	180	225	200	359	995	125	95	388	305	320	250	400	318	18	30	226	100
50-250/3702	200L	x		65 3)	50	100	65	168	184	85	14	400	422	19	180	225	200	359	995	125	95	388	305	320	250	400	318	18	30	226	100

1) Rc = ISO 7/1; G = ISO 228/1 2) Etabloc BN: DN=ISO 7005-3/DN.../PN10/21; Etabloc SN: DN=EN 1092-2/DN.../PN16/21/JS1025/B; Etabloc CN: DN=EN 1092-1/DN.../PN16/21/B

3) bei diesen Baugrößen sind die Motorfüße 20 mm zu unterbauen

3) the motor feet of these sizes are to be underpinned by 20 mm thick shims

3) Il faut appuyer les pieds de moteur de ces tailles de construction avec des feuillets de 20 mm

3) Con queste grandezze sotto i piedi del motore si devono sistemare degli spessori da 20 mm5)

3) Bij deze grootten dienen de motorvoeten 20 mm opgevuld te worden

4) h₁ ≥ h₄

5) Flansche DN₁ 65 / DN₂ 65 4 Loch

5) Flanges DN₁ 65 / DN₂ 65 4-hole

5) Brides DN₁ 65 / DN₂ 65 4 trous

5) Bridas DN₁ 65 / DN₂ 65 4 taladro

5) Flens DN₁ 65 / DN₂ 65 vier gaten

Etabloc BN, SN, CN 65-125/... bis 65-250/..., n = 2900 1/min, n = 3500 1/min

ohne Motorfuß (bis Motorbaugröße 112 = 4 kW)
 mit Motorfuß (ab Motorbaugröße 132 = 5,5 kW)
 without motor foot (up to motor size 112 = 4 kW)
 with motor foot (motor size 132 = 5,5 kW and above)
 sans pied de moteur (jusqu'à taille de moteur 112 = 4 kW)

avec pied de moteur (à partir de la taille de moteur 132 = 5,5 kW)
 senza piede di fusione (fino alla grandezza del motore 112 = 4 kW)
 con piede di fusione (a partire della grandezza del motore 132 = 5,5 kW)
 zonder motorvoet (tot motorgrootte 112 = 4 kW)
 met motorvoet (vanaf motorgrootte 132 = 5,5 kW)

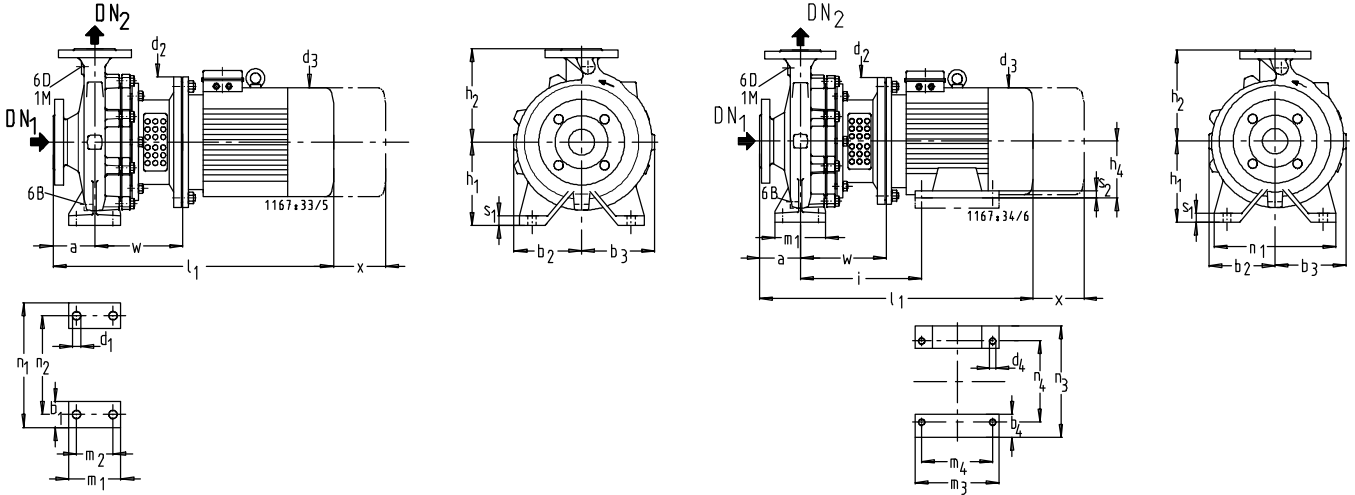

	Etabloc G, M Etabloc GN, MN, BN	Etabloc SN, CN			
		DN ₂ 32 - DN ₂ 80	DN ₂ 100	DN ₂ 32 - DN ₂ 80	DN ₂ 100 - DN ₂ 150
1 M	Druckmessgerät-Anschluss / Pressure gauge connection / Indicateur de pression / Manomètre / Manometro / Manometer	Rc 3/8 ¹⁾	Rc 1/2 ¹⁾	G 3/8 ¹⁾	G 1/2 ¹⁾
6 B	Förderflüssigkeit-Entleerung / Casing drain / Vidange du liquide pompé / Scarico del liquido convogliato / Vloeistof- aftap	Rc 3/8 ¹⁾	Rc 1/2 ¹⁾	G 3/8 ¹⁾	G 1/2 ¹⁾
6 D	Förderflüssigkeit-Auffüllen und Entlüften / Filling and venting of medium handled / Remplissage et purge d'air du liquide pompé / Riempimento del liquido convogliato spurgo dell'aria / Vloeistof vullen en ontluchten	Rc 3/8 ¹⁾	Rc 1/2 ¹⁾	G 3/8 ¹⁾	G 1/2 ¹⁾

Etabloc BN, SN, CN	Ⓜ	n = 2900	n = 3500	Toleranz der Anschlussmaße nach EN 735																											
				DN ₁ 2)	DN ₂ 2)	a	b ₁ ≈	b ₂ ≈	b ₃ ≈	b ₄ ≈	d ₁	d ₂	d ₃ ≈	d ₄	h ₁	h ₂	h ₄	i	l ₁ ≈	m ₁ ≈	m ₂	m ₃ ≈	m ₄	n ₁	n ₂	n ₃ ≈	n ₄	s ₁	s ₂	w	x
65-125/402	112M	x		80	65 ⁵⁾	100	65	120	148		14	250	234	160	180			641	125	95			280	212			18		170	100	
65-125/552 ³⁾⁴⁾	132S	x	x	80	65 ⁵⁾	100	65	120	148	55	14	300	266	12	160	180	132	282	706	125	95	220	140	280	212	270	216	18	15	193	100
65-125/752 ³⁾⁴⁾	132S	x	x	80	65 ⁵⁾	100	65	120	148	55	14	300	266	12	160	180	132	282	706	125	95	220	140	280	212	270	216	18	15	193	100
65-125/1102 ³⁾⁴⁾	160M	x	x	80	65 ⁵⁾	100	65	120	148	70	14	350	325	15	160	180	160	334	872	125	95	300	210	280	212	320	254	18	21	226	100
65-125/1502 ³⁾⁴⁾	160M		x	80	65 ⁵⁾	100	65	120	148	70	14	350	325	15	160	180	160	334	872	125	95	300	210	280	212	320	254	18	21	226	100
65-160/752 ³⁾⁴⁾	132S	x		80	65 ⁵⁾	100	65	130	158	55	14	300	266	12	160	200	132	282	706	125	95	220	140	280	212	270	216	18	15	193	100
65-160/1102 ³⁾⁴⁾	160M	x	x	80	65 ⁵⁾	100	65	130	158	70	14	350	325	15	160	200	160	334	872	125	95	300	210	280	212	320	254	18	21	226	100
65-160/1502 ³⁾⁴⁾	160M	x	x	80	65 ⁵⁾	100	65	130	158	70	14	350	325	15	160	200	160	334	872	125	95	300	210	280	212	320	254	18	21	226	100
65-160/1852 ³⁾⁴⁾	160L		x	80	65 ⁵⁾	100	65	130	158	70	14	350	325	15	160	200	160	334	878	125	95	314	254	280	212	320	254	18	21	226	100
65-160/2202	180M	x		80	65 ⁵⁾	100	65	130	158	80	14	350	370	15	160	200	180	347	936	125	95	320	241	280	212	360	279	18	23	226	100
65-160/3002	200L		x	80	65 ⁵⁾	100	65	130	158	85	14	400	422	19	160	200	200	359	995	125	95	388	305	280	212	400	318	18	30	226	100
65-200/1502 ³⁾⁴⁾	160M	x		80	65 ⁵⁾	100	65	154	177	70	14	350	325	15	180	225	160	334	872	125	95	300	210	320	250	320	254	18	21	226	140
65-200/1852 ³⁾⁴⁾	160L	x	x	80	65 ⁵⁾	100	65	154	177	70	14	350	325	15	180	225	160	334	878	125	95	314	254	320	250	320	254	18	21	226	140
65-200/2202 ⁴⁾	180M	x	x	80	65 ⁵⁾	100	65	154	177	80	14	350	370	15	180	225	180	347	936	125	95	320	250	320	250	360	279	18	23	226	140
65-200/3002	200L		x	80	65 ⁵⁾	100	65	154	177	85	14	400	422	19	180	225	200	359	995	125	95	388	305	320	250	400	318	18	30	226	140
65-200/3702	200L		x	80	65 ⁵⁾	100	65	154	177	85	14	400	422	19	180	225	200	359	995	125	95	388	305	320	250	400	318	18	30	226	140
65-250/2202 ⁴⁾	180M	x		80	65 ⁵⁾	100	80	180	200	80	18	350	370	15	200	250	180	367	956	160	120	320	241	360	280	360	279	20	23	246	140
65-250/3002 ⁴⁾	200L	x		80	65 ⁵⁾	100	80	180	200	85	18	400	422	19	200	250	200	379	1015	160	120	388	305	360	280	400	318	20	30	246	140
65-250/3702 ⁴⁾	200L	x		80	65 ⁵⁾	100	80	180	200	85	18	400	422	19	200	250	200	379	1015	160	120	388	305	360	280	400	318	20	30	246	140
65-250/4502	225M	x		80	65	100	80	180	200	100	18	450	468	19	200	250	225	419	1125	160	120	410	311	360	280	450	356	20	35	270	140

- 1) Rc = ISO 7/1; G = ISO 228/1 2) Etabloc BN: DN=ISO 7005-3/DN.../PN10/21; Etabloc SN: DN=EN 1092-2/DN.../PN16/21/JS1025/B; Etabloc CN: DN=EN 1092-1/DN.../PN16/21/B
- 3) bei diesen Baugrößen sind die Motorfüße 20 mm zu unterbauen
 3) the motor feet of these sizes are to be underpinned by 20 mm thick shims
 3) Il faut appuyer les pieds de moteur de ces tailles de construction avec des feuillets de 20 mm
 3) Con queste grandezze sotto i piedi del motore si devono sistemare degli spessori da 20 mm
 3) Bij deze grootten dienen de motorvoeten 20 mm opgevuld te worden
- 4) h₁ ≥ h₄
- 5) Flanges DN₁ 65 / DN₂ 65 4 Loch
 5) Flanges DN₁ 65 / DN₂ 65 4-hole
 5) Brides DN₁ 65 / DN₂ 65 4 trous
 5) Bidas DN₁ 65 / DN₂ 65 4 taladro
 5) Flens DN₁ 65 / DN₂ 65 vier gaten

Etabloc BN, SN, CN 80-160/... bis 100-200/..., n = 2900 1/min, n = 3500 1/min

ohne Motorfuß (bis Motorbaugröße 112 = 4 kW)
 mit Motorfuß (ab Motorbaugröße 132 = 5,5 kW)
 without motor foot (up to motor size 112 = 4 kW)
 with motor foot (motor size 132 = 5,5 kW and above)
 sans pied de moteur (jusqu'à taille de moteur 112 = 4 kW)

avec pied de moteur (à partir de la taille de moteur 132 = 5,5 kW)
 senza piede di fusione (fino alla grandezza del motore 112 = 4 kW)
 con piede di fusione (a partire della grandezza del motore 132 = 5,5 kW)
 zonder motorvoet (tot motorgrootte 112 = 4 kW)
 met motorvoet (vanaf motorgrootte 132 = 5,5 kW)

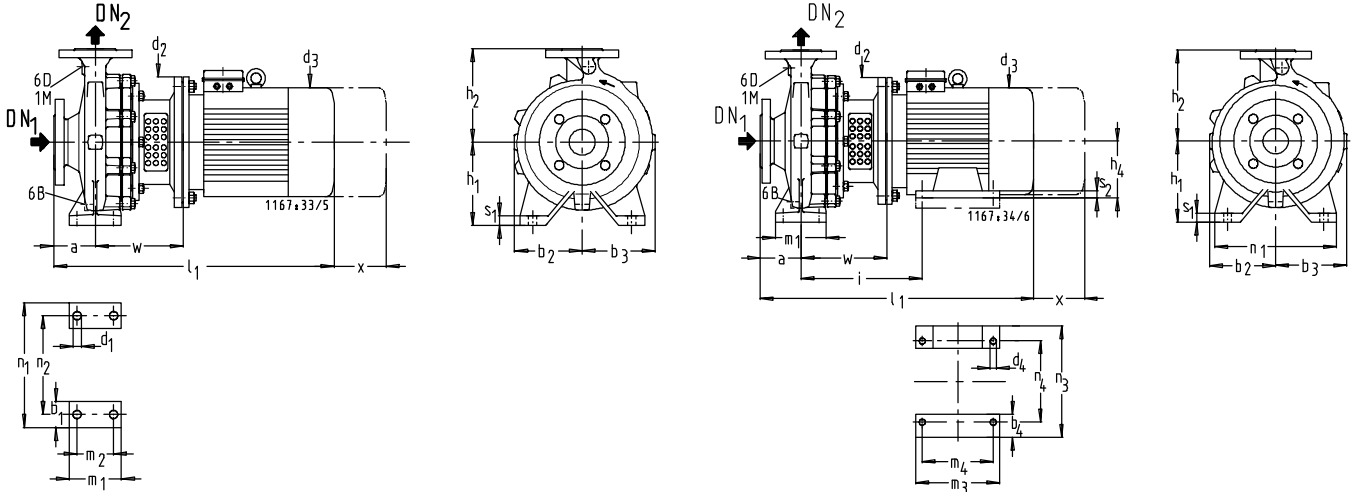

		Etabloc G, M		Etabloc SN, CN			
		Etabloc GN, MN, BN		DN ₂ 32 - DN ₂ 80	DN ₂ 100	DN ₂ 32 - DN ₂ 80	DN ₂ 100 - DN ₂ 150
1 M	Druckmessgerät-Anschluss / Pressure gauge connection / Indicateur de pression / Manomètre / Manometro / Manometer	Rc 3/8 1)	Rc 1/2 1)	G 3/8 1)	G 1/2 1)		
6 B	Förderflüssigkeit-Entleerung / Casing drain / Vidange du liquide pompé / Scarico del liquido convogliato / Vloeistof- aftap	Rc 3/8 1)	Rc 1/2 1)	G 3/8 1)	G 1/2 1)		
6 D	Förderflüssigkeit-Auffüllen und Entlüften / Filling and venting of medium handled / Remplissage et purge d'air du liquide pompé / Riempimento del liquido convogliato spurgo dell'aria / Vloeistof vullen en ontluften	Rc 3/8 1)	Rc 1/2 1)	G 3/8 1)	G 1/2 1)		

Etabloc BN, SN, CN	M	n = 2900	n = 3500	Toleranz der Anschlussmaße nach EN 735																											
				DN ₁ 2)	DN ₂ 2)	a	b ₁ ≈	b ₂ ≈	b ₃ ≈	b ₄ ≈	d ₁	d ₂	d ₃ ≈	d ₄	h ₁	h ₂	h ₄	i	l ₁ ≈	m ₁ ≈	m ₂	m ₃ ≈	m ₄	n ₁	n ₂	n ₃ ≈	n ₄	s ₁	s ₂	w	x
80-160/1102 3)4)	160M	x		100	80	125	65	153	192	70	14	350	325	15	180	225	160	334	897	125	95	300	210	320	250	320	254	18	21	226	140
80-160/1502 3)4)	160M	x		100	80	125	65	153	192	70	14	350	325	15	180	225	160	334	897	125	95	300	210	320	250	320	254	18	21	226	140
80-160/1852 3)4)	160L	x		100	80	125	65	153	192	70	14	350	325	15	180	225	160	334	903	125	95	314	254	320	250	320	254	18	21	226	140
80-160/2202 4)	180M	x	x	100	80	125	65	153	192	80	14	350	370	15	180	225	180	347	961	125	95	320	241	320	250	360	279	18	23	226	140
80-160/3002	200L	x	x	100	80	125	65	153	192	85	14	400	422	19	180	225	200	359	1020	125	95	388	305	320	250	400	318	18	30	226	140
80-160/3702	200L	x	x	100	80	125	65	153	192	85	14	400	422	19	180	225	200	359	1020	125	95	388	305	320	250	400	318	18	30	226	140
80-200/1852 3)4)	160L	x		100	80	125	65	161	189	70	14	350	325	15	180	250	160	354	923	125	95	314	254	345	280	320	254	18	21	246	140
80-200/2202 4)	180M	x		100	80	125	65	161	189	80	14	350	370	15	180	250	180	367	981	125	95	320	241	345	280	360	279	18	23	246	140
80-200/3002	200L	x		100	80	125	65	161	189	85	14	400	422	19	180	250	200	379	1040	125	95	388	305	345	280	400	318	18	30	246	140
80-200/3702	200L	x		100	80	125	65	161	189	85	14	400	422	19	180	250	200	379	1040	125	95	388	305	345	280	400	318	18	30	246	140
80-200/4502	225M	x	x	100	80	125	65	161	189	100	14	450	468	19	180	250	225	419	1150	125	95	410	311	345	280	450	356	18	35	270	140
80-250/3002 4)	200L	x		100	80	125	80	184	210	85	18	400	422	19	200	280	200	379	1040	160	120	388	305	400	315	400	318	18	30	246	140
80-250/3702 4)	200L	x		100	80	125	80	184	210	85	18	400	422	19	200	280	200	379	1040	160	120	388	305	400	315	400	318	18	30	246	140
80-250/4502	225M	x		100	80	125	80	184	210	100	18	450	468	19	200	280	225	419	1150	160	120	410	311	400	315	450	356	18	35	270	140
100-160/2202	180M	x		125	100	125	80	178	225	80	18	350	370	15	200	280	180	367	981	160	120	320	241	360	280	360	279	18	23	246	140
100-160/3002 4)	200L	x		125	100	125	80	178	225	85	18	400	422	19	200	280	200	379	1040	160	120	388	305	360	280	400	318	18	30	246	140
100-160/3702 4)	200L	x	x	125	100	125	80	178	225	85	18	400	422	19	200	280	200	379	1040	160	120	388	305	360	280	400	318	18	30	246	140
100-160/4502	225M	x	x	125	100	125	80	178	225	100	18	450	468	19	200	280	225	419	1150	160	120	410	311	360	280	450	356	18	35	270	140
100-200/3002 4)	200L	x		125	100	125	80	173	213	85	18	400	422	19	200	280	200	379	1040	160	120	388	305	360	280	400	318	18	30	246	140
100-200/3702 4)	200L	x		125	100	125	80	173	213	85	18	400	422	19	200	280	200	379	1040	160	120	388	305	360	280	400	318	18	30	246	140
100-200/4502	225M	x		125	100	125	80	173	213	100	18	450	468	19	200	280	225	419	1150	160	120	410	311	360	280	450	356	18	35	270	140

1) Rc = ISO 7/1; G = ISO 228/1 2) Etabloc BN: DN=ISO 7005-3/DN.../PN10/21; Etabloc SN: DN=EN 1092-2/DN.../PN16/21/JS1025/B; Etabloc CN: DN=EN 1092-1/DN.../PN16/21/B

3) bei diesen Baugrößen sind die Motorfüße 20 mm zu unterbauen

3) the motor feet of these sizes are to be underpinned by 20 mm thick shims

3) Il faut appuyer les pieds de moteur de ces tailles de construction avec des feuillards de 20 mm

3) Con queste grandezze sotto i piedi del motore si devono sistemare degli spessori da 20 mm5)

3) Bij deze grootten dienen de motorvoeten 20 mm opgevuld te worden

4) $h_1 \geq h_4$

5) Flansche DN₁ 65 / DN₂ 65 4 Loch

5) Flanges DN₁ 65 / DN₂ 65 4-hole

5) Brides DN₁ 65 / DN₂ 65 4 trous

5) Bridas DN₁ 65 / DN₂ 65 4 taladro

5) Flens DN₁ 65 / DN₂ 65 vier gaten

Etabloc BN, SN, CN 32-125.1/... bis 32-200/..., n = 1450 1/min, n = 1750 1/min

ohne Motorfuß (bis Motorbaugröße 112 = 4 kW)
 mit Motorfuß (ab Motorbaugröße 132 = 5,5 kW)
 without motor foot (up to motor size 112 = 4 kW)
 with motor foot (motor size 132 = 5,5 kW and above)
 sans pied de moteur (jusqu'à taille de moteur 112 = 4 kW)

avec pied de moteur (à partir de la taille de moteur 132 = 5,5 kW)
 senza piede di fusione (fino alla grandezza del motore 112 = 4 kW)
 con piede di fusione (a partire della grandezza del motore 132 = 5,5 kW)
 zonder motorvoet (tot motorgrootte 112 = 4 kW)
 met motorvoet (vanaf motorgrootte 132 = 5,5 kW)

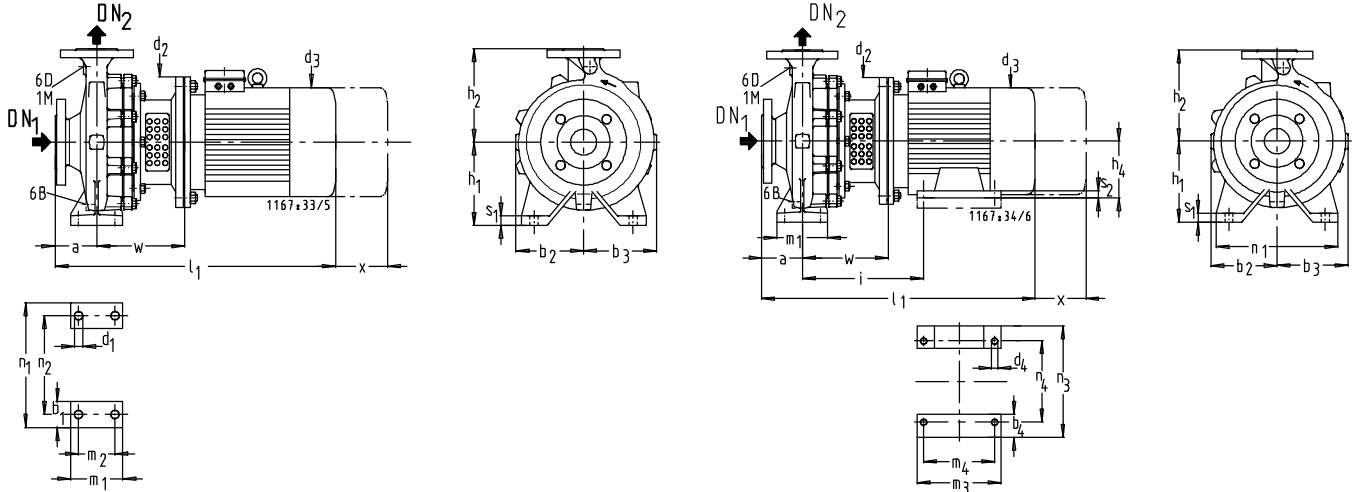

	Etabloc G, M Etabloc GN, MN, BN		Etabloc SN, CN	
	DN ₂ 32 - DN ₂ 80	DN ₂ 100	DN ₂ 32 - DN ₂ 80	DN ₂ 100 - DN ₂ 150
1 M	Druckmessgerät-Anschluss / Pressure gauge connection / Indicateur de pression / Manomètre / Manometro / Manometer			
6 B	Förderflüssigkeit-Entleerung / Casing drain / Vidange du liquide pompé / Scarico del liquido convogliato / Vloeistof- aftap			
6 D	Förderflüssigkeit-Auffüllen und Entlüften / Filling and venting of medium handled / Remplissage et purge d'air du liquide pompé / Riempimento del liquido convogliato spurgo dell'aria / Vloeistof vullen en ontluchten			

Etabloc BN, SN, CN	M	n = 1450	n = 1750	Toleranz der Anschlussmaße nach EN 735																							
				DN ₁ 2)	DN ₂ 2)	a	b ₁	b ₂	b ₃	b ₄	d ₁	d ₂	d ₃	d ₄	h ₁	h ₂	h ₄	i	l ₁	m ₁	m ₂	m ₃	m ₄	n ₁	n ₂	n ₃	n ₄
32-125.1/024	71	x	x	50	32	80	50	113	113	14	160	145	112	140		453	100	70			190	140			15	136	100
32-125.1/034	71	x	x	50	32	80	50	113	113	14	160	145	112	140		453	100	70			190	140			15	136	100
32-125.1/054	80	x	x	50	32	80	50	113	113	14	200	162	112	140		491	100	70			190	140			15	156	100
32-160.1/034	71	x	x	50	32	80	50	116	125	14	160	145	132	160		453	100	70			240	190			15	136	100
32-160.1/054	80	x	x	50	32	80	50	116	125	14	200	162	132	160		491	100	70			240	190			15	156	100
32-160.1/074	80	x	x	50	32	80	50	116	125	14	200	162	132	160		491	100	70			240	190			15	156	100
32-160.1/114	90S		x	50	32	80	50	116	125	14	200	190	132	160		518	100	70			240	190			15	156	100
32-200.1/054	80	x	x	50	32	80	50	128	137	14	200	162	160	180		491	100	70			240	190			18	156	100
32-200.1/074	80	x	x	50	32	80	50	128	137	14	200	162	160	180		491	100	70			240	190			18	156	100
32-200.1/114	90S		x	50	32	80	50	128	137	14	200	190	160	180		518	100	70			240	190			18	156	100
32-200.1/154	90L	x	x	50	32	80	50	128	137	14	200	190	160	180		544	100	70			240	190			18	156	100
32-200.1/224	100L	x	x	50	32	80	50	128	137	14	250	213	160	180		597	100	70			240	190			18	170	100
32-250.1/074	80	x		50	32	100	65	164	171	14	200	162	180	225		511	125	95			320	250			18	156	100
32-250.1/114	90S	x	x	50	32	100	65	164	171	14	200	190	180	225		538	125	95			320	250			18	156	100
32-250.1/154	90L	x	x	50	32	100	65	164	171	14	200	190	180	225		564	125	95			320	250			18	156	100
32-250.1/224	100L	x	x	50	32	100	65	164	171	14	250	213	180	225		617	125	95			320	250			18	170	100
32-250.1/304	100L		x	50	32	100	65	164	171	14	250	213	180	225		652	125	95			320	250			18	170	100
32-125/034	71	x	x	50	32	80	50	113	113	14	160	145	112	140		453	100	70			190	140			15	136	100
32-125/054	80	x	x	50	32	80	50	113	113	14	200	162	112	140		491	100	70			190	140			15	156	100
32-125/074	80		x	50	32	80	50	113	113	14	200	162	112	140		491	100	70			190	140			15	156	100
32-160/054	80	x	x	50	32	80	50	113	125	14	200	162	132	160		491	100	70			240	190			15	156	100
32-160/074	80		x	50	32	80	50	113	125	14	200	162	132	160		491	100	70			240	190			15	156	100
32-160/114	90S		x	50	32	80	50	113	125	14	200	190	132	160		518	100	70			240	190			15	156	100
32-200/054	80	x		50	32	80	50	132	141	14	200	162	160	180		491	100	70			240	190			18	156	100
32-200/074	80	x	x	50	32	80	50	132	141	14	200	162	160	180		491	100	70			240	190			18	156	100
32-200/114	90S	x	x	50	32	80	50	132	141	14	200	190	160	180		518	100	70			240	190			18	156	100
32-200/154	90L		x	50	32	80	50	132	141	14	200	190	160	180		544	100	70			240	190			18	156	100
32-200/224	100L		x	50	32	80	50	132	141	14	250	213	160	180		597	100	70			240	190			18	170	100

- 1) Rc = ISO 7/1; G = ISO 228/1
- 2) Etabloc BN: DN=ISO 7005-3/DN.../PN10/21; Etabloc SN: DN=EN 1092-2/DN.../PN16/21/JS1025/B; Etabloc CN: DN=EN 1092-1/DN.../PN16/21/B / DN200=EN 1092-1/DN200/PN10/21/B
- 3) bei diesen Baugrößen sind die Motorfüße 20 mm zu unterbauen
 3) the motor feet of these sizes are to be underpinned by 20 mm thick shims
 3) Il faut appuyer les pieds de moteur de ces tailles de construction avec des feuillards de 20 mm
 3) Con queste grandezze sotto i piedi del motore si devono sistemare degli spessori da 20 mm5)
 3) Bij deze grootten dienen de motorvoeten 20 mm opgevuld te worden
- 4) h₁ ≥ h₄
- 5) Flansche DN₁ 65 / DN₂ 65 4 Loch
 5) Flanges DN₁ 65 / DN₂ 65 4-hole
 5) Brides DN₁ 65 / DN₂ 65 4 trous
 5) Bidas DN₁ 65 / DN₂ 65 4 taladro
 5) Flens DN₁ 65 / DN₂ 65 vier gaten

Etabloc BN, SN, CN 32-250/... bis 40-250/..., n = 1450 1/min, n = 1750 1/min

ohne Motorfuß (bis Motorbaugröße 112 = 4 kW)
 mit Motorfuß (ab Motorbaugröße 132 = 5,5 kW)
 without motor foot (up to motor size 112 = 4 kW)
 with motor foot (motor size 132 = 5,5 kW and above)
 sans pied de moteur (jusqu'à taille de moteur 112 = 4 kW)

avec pied de moteur (à partir de la taille de moteur 132 = 5,5 kW)
 senza piede di fusione (fino alla grandezza del motore 112 = 4 kW)
 con piede di fusione (a partire della grandezza del motore 132 = 5,5 kW)
 zonder motorvoet (tot motorgrootte 112 = 4 kW)
 met motorvoet (vanaf motorgrootte 132 = 5,5 kW)

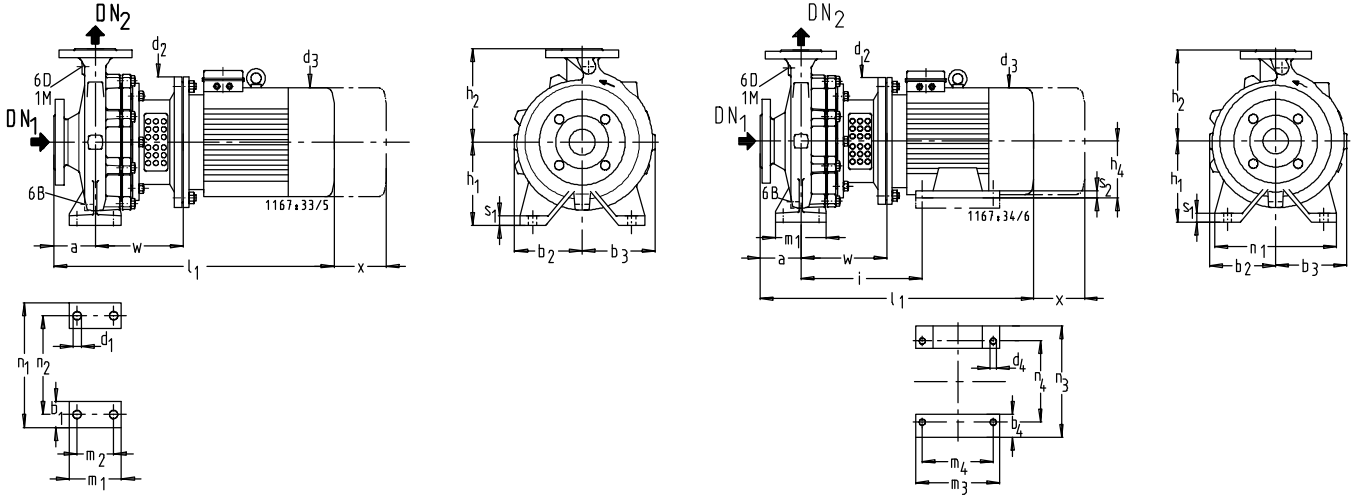

		Etabloc G, M Etabloc GN, MN, BN		Etabloc SN, CN	
		DN ₂ 32 - DN ₂ 80	DN ₂ 100	DN ₂ 32 - DN ₂ 80	DN ₂ 100 - DN ₂ 150
1 M	Druckmessgerät-Anschluss / Pressure gauge connection / Indicateur de pression / Manomètre / Manometro / Manometer	Rc 3/8 1)	Rc 1/2 1)	G 3/8 1)	G 1/2 1)
6 B	Förderflüssigkeit-Entleerung / Casing drain / Vidange du liquide pompé / Scarico del liquido convogliato / Vloeistof- aftap	Rc 3/8 1)	Rc 1/2 1)	G 3/8 1)	G 1/2 1)
6 D	Förderflüssigkeit-Auffüllen und Entlüften / Filling and venting of medium handled / Remplissage et purge d'air du liquide pompé / Riempimento del liquido convogliato spurgo dell'aria / Vloeistof vullen en ontluften	Rc 3/8 1)	Rc 1/2 1)	G 3/8 1)	G 1/2 1)

Etabloc BN, SN, CN	M	n = 1450	n = 1750	Toleranz der Anschlussmaße nach EN 735																											
				DN ₁ 2)	DN ₂ 2)	a	b ₁	b ₂	b ₃	b ₄	d ₁	d ₂	d ₃	d ₄	h ₁	h ₂	h ₄	i	l ₁	m ₁	m ₂	m ₃	m ₄	n ₁	n ₂	n ₃	n ₄	s ₁	s ₂	w	x
32-250/114	90S	x		50	32	100	65	170	176	14	200	190	180	225				538	125	95			320	250				18		156	100
32-250/154	90L	x		50	32	100	65	170	176	14	200	190	180	225				564	125	95			320	250				18		156	100
32-250/224	100L	x	x	50	32	100	65	170	176	14	250	213	180	225				617	125	95			320	250				18		170	100
32-250/304	100L		x	50	32	100	65	170	176	14	250	213	180	225				652	125	95			320	250				18		170	100
32-250/404	112M		x	50	32	100	65	170	176	14	250	234	180	225				641	125	95			320	250				18		170	100
32-250/554 3)4)	132S		x	50	32	100	65	170	176	55	14	300	266	12	180	225	132	282	706	125	95	220	140	320	250	270	216	18	15	193	100
40-125/024	71	x		65 5)	40	80	50	113	113	14	160	145	112	140				453	100	70			210	160				15		136	100
40-125/034	71	x		65 5)	40	80	50	113	113	14	160	145	112	140				453	100	70			210	160				15		136	100
40-125/054	80	x	x	65 5)	40	80	50	113	113	14	200	162	112	140				491	100	70			210	160				15		156	100
40-125/074	80		x	65 5)	40	80	50	113	113	14	200	162	112	140				491	100	70			210	160				15		156	100
40-125/114	90S		x	65 5)	40	80	50	113	113	14	200	190	112	140				518	100	70			210	160				15		156	100
40-160/054	80	x		65 5)	40	80	50	115	131	14	200	162	132	160				491	100	70			240	190				15		156	100
40-160/074	80	x	x	65 5)	40	80	50	115	131	14	200	162	132	160				491	100	70			240	190				15		156	100
40-160/114	90S	x	x	65 5)	40	80	50	115	131	14	200	190	132	160				518	100	70			240	190				15		156	100
40-160/154	90L		x	65 5)	40	80	50	115	131	14	200	190	132	160				544	100	70			240	190				15		156	100
40-160/224	100L		x	65 5)	40	80	50	115	131	14	250	213	132	160				597	100	70			240	190				15		170	100
40-200/074	80	x		65 5)	40	100	50	140	152	14	200	162	132	180				511	100	70			265	212				18		156	100
40-200/114	90S	x		65 5)	40	100	50	140	152	14	200	190	160	180				538	100	70			265	212				18		156	100
40-200/154	90L	x	x	65 5)	40	100	50	140	152	14	200	190	160	180				564	100	70			265	212				18		156	100
40-200/224	100L		x	65 5)	40	100	50	140	152	14	250	213	160	180				617	100	70			265	212				18		170	100
40-200/304	100L		x	65 5)	40	100	50	140	152	14	250	213	160	180				652	100	70			265	212				18		170	100
40-250/114	90S	x		65 5)	40	100	65	165	178	14	200	190	180	225				538	125	95			320	250				18		156	100
40-250/154	90L	x		65 5)	40	100	65	165	178	14	200	190	180	225				564	125	95			320	250				18		156	100
40-250/224	100L	x	x	65 5)	40	100	65	165	178	14	250	213	180	225				617	125	95			320	250				18		170	100
40-250/304	100L	x	x	65 5)	40	100	65	165	178	14	250	213	180	225				652	125	95			320	250				18		170	100
40-250/404	112M		x	65 5)	40	100	65	165	178	14	250	234	180	225				641	125	95			320	250				18		170	100
40-250/554 3)4)	132S		x	65 5)	40	100	65	165	178	55	14	300	266	12	180	225	132	282	706	125	95	220	140	320	250	270	216	18	15	193	100

- 1) Rc = ISO 7/1; G = ISO 228/1
 2) Etabloc BN: DN=ISO 7005-3/DN.../PN10/21; Etabloc SN: DN=EN 1092-2/DN.../PN16/21/JS1025/B; Etabloc CN: DN=EN 1092-1/DN.../PN16/21/B / DN200=EN 1092-1/DN200/PN10/21/B
 3) bei diesen Baugrößen sind die Motorfüße 20 mm zu unterbauen
 3) the motor feet of these sizes are to be underpinned by 20 mm thick shims
 3) Il faut appuyer les pieds de moteur de ces tailles de construction avec des feuillards de 20 mm
 3) Con queste grandezze sotto i piedi del motore si devono sistemare degli spessori da 20 mm5)
 3) Bij deze grootten dienen de motorvoeten 20 mm opgevoeld te worden
 4) $h_1 \geq h_4$
 5) Flansche DN₁ 65 / DN₂ 65 4 Loch
 5) Flanges DN₁ 65 / DN₂ 65 4-hole
 5) Brides DN₁ 65 / DN₂ 65 4 trous
 5) Bridas DN₁ 65 / DN₂ 65 4 taladro
 5) Flens DN₁ 65 / DN₂ 65 vier gaten

Etabloc BN, SN, CN 40-315/... bis 50-250/..., n = 1450 1/min, n = 1750 1/min

ohne Motorfuß (bis Motorbaugröße 112 = 4 kW)
 mit Motorfuß (ab Motorbaugröße 132 = 5,5 kW)
 without motor foot (up to motor size 112 = 4 kW)
 with motor foot (motor size 132 = 5,5 kW and above)
 sans pied de moteur (jusqu'à taille de moteur 112 = 4 kW)

avec pied de moteur (à partir de la taille de moteur 132 = 5,5 kW)
 senza piede di fusione (fino alla grandezza del motore 112 = 4 kW)
 con piede di fusione (a partire della grandezza del motore 132 = 5,5 kW)
 zonder motorvoet (tot motorgrootte 112 = 4 kW)
 met motorvoet (vanaf motorgrootte 132 = 5,5 kW)

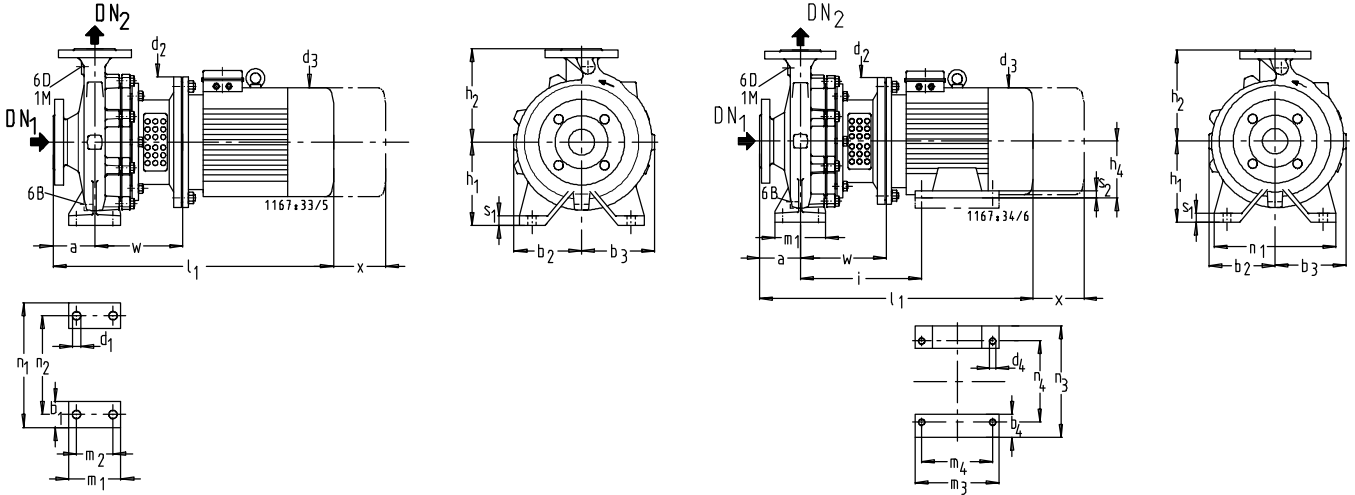

		Etabloc G, M		Etabloc SN, CN	
		Etabloc GN, MN, BN	DN ₂ 32 - DN ₂ 80	DN ₂ 100	DN ₂ 32 - DN ₂ 80
1 M	Druckmessgerät-Anschluss / Pressure gauge connection / Indicateur de pression / Manomètre / Manometro / Manometer	Rc 3/8 ¹⁾	Rc 1/2 ¹⁾	G 3/8 ¹⁾	G 1/2 ¹⁾
6 B	Förderflüssigkeit-Entleerung / Casing drain / Vidange du liquide pompé / Scarico del liquido convogliato / Vloeistof- aftap	Rc 3/8 ¹⁾	Rc 1/2 ¹⁾	G 3/8 ¹⁾	G 1/2 ¹⁾
6 D	Förderflüssigkeit-Auffüllen und Entlüften / Filling and venting of medium handled / Remplissage et purge d'air du liquide pompé / Riempimento del liquido convogliato spurgo dell'aria / Vloeistof vullen en ontluchten	Rc 3/8 ¹⁾	Rc 1/2 ¹⁾	G 3/8 ¹⁾	G 1/2 ¹⁾

Etabloc BN, SN, CN	M	n = 1450	n = 1750	Toleranz der Anschlussmaße nach EN 735																											
				DN ₁	DN ₂	a	b ₁	b ₂	b ₃	b ₄	d ₁	d ₂	d ₃	d ₄	h ₁	h ₂	h ₄	i	l ₁	m ₁	m ₂	m ₃	m ₄	n ₁	n ₂	n ₃	n ₄	s ₁	s ₂	w	x
40-315/224	100L	x		65 ⁵⁾	40	125	65	194	203		14	250	213		225	250			662	125	95			345	280			18		190	100
40-315/304	100L	x		65 ⁵⁾	40	125	65	194	203		14	250	213		225	250			697	125	95			345	280			18		190	100
40-315/404	112M	x	x	65 ⁵⁾	40	125	65	194	203		14	250	234		225	250			686	125	95			345	280			18		190	100
40-315/554 ³⁾⁴⁾	132S	x	x	65 ⁵⁾	40	125	65	194	203	55	14	300	266	12	225	250	132	302	751	125	95	220	140	345	280	270	216	18	15	213	100
40-315/754 ³⁾⁴⁾	132M		x	65 ⁵⁾	40	125	65	194	203	59	14	300	298	12	225	250	132	302	779	125	95	240	178	345	280	270	216	18	15	213	100
40-315/1104 ³⁾⁴⁾	160M		x	65 ⁵⁾	40	125	65	194	203	70	14	350	325	15	225	250	160	354	917	125	95	300	210	345	280	320	254	18	21	246	100
50-125/054	80	x		65 ⁵⁾	50	100	50	113	128		14	200	162		132	160			511	100	70			240	190			18		156	100
50-125/074	80	x	x	65 ⁵⁾	50	100	50	113	128		14	200	162		132	160			511	100	70			240	190			18		156	100
50-125/114	90S	x	x	65 ⁵⁾	50	100	50	113	128		14	200	190		132	160			538	100	70			240	190			18		156	100
50-125/154	90L		x	65 ⁵⁾	50	100	50	113	128		14	200	190		132	160			564	100	70			240	190			18		156	100
50-160/074	80	x		65 ⁵⁾	50	100	50	126	147		14	200	162		160	180			511	100	70			265	212			18		156	100
50-160/114	90S	x	x	65 ⁵⁾	50	100	50	126	147		14	200	190		160	180			538	100	70			265	212			18		156	100
50-160/154	90L	x	x	65 ⁵⁾	50	100	50	126	147		14	200	190		160	180			564	100	70			265	212			18		156	100
50-160/224	100L		x	65 ⁵⁾	50	100	50	126	147		14	250	213		160	180			617	100	70			265	212			18		170	100
50-160/304	100L		x	65 ⁵⁾	50	100	50	126	147		14	250	213		160	180			652	100	70			265	212			18		170	100
50-200/154	90L	x		65 ⁵⁾	50	100	50	145	165		14	200	190		160	200			564	100	70			265	212			18		156	100
50-200/224	100L	x	x	65 ⁵⁾	50	100	50	145	165		14	250	213		160	200			617	100	70			265	212			18		170	100
50-200/304	100L	x	x	65 ⁵⁾	50	100	50	145	165		14	250	213		160	200			652	100	70			265	212			18		170	100
50-200/404	112M		x	65 ⁵⁾	50	100	50	145	165		14	250	234		160	200			641	100	70			265	212			18		170	100
50-200/554 ³⁾⁴⁾	132S		x	65 ⁵⁾	50	100	50	145	165	55	14	300	266	12	160	200	132	282	706	100	70	220	140	265	212	270	216	18	15	193	100
50-250/224	100L	x	x	65 ⁵⁾	50	100	65	168	184		14	250	213		180	225			617	125	95			320	250			18		170	100
50-250/304	100L	x		65 ⁵⁾	50	100	65	168	184		14	250	213		180	225			652	125	95			320	250			18		170	100
50-250/404	112M	x	x	65 ⁵⁾	50	100	65	168	184		14	250	234		180	225			641	125	95			320	250			18		170	100
50-250/554 ³⁾⁴⁾	132S		x	65 ⁵⁾	50	100	65	168	184	55	14	300	266	12	180	225	132	282	706	125	95	220	140	320	250	270	216	18	15	193	100
50-250/754 ³⁾⁴⁾	132M		x	65 ⁵⁾	50	100	65	168	184	59	14	300	298	12	180	225	132	282	734	125	95	240	178	320	250	270	216	18	15	193	100
50-250/1104 ³⁾⁴⁾	160M		x	65 ⁵⁾	50	100	65	168	184	70	14	350	325	15	180	225	160	334	872	125	95	300	210	320	250	320	254	18	21	226	100

1) Rc = ISO 7/1; G = ISO 228/1
 2) Etabloc BN: DN=ISO 7005-3/DN.../PN10/21; Etabloc SN: DN=EN 1092-2/DN.../PN16/21/JS1025/B; Etabloc CN: DN=EN 1092-1/DN.../PN16/21/B / DN200=EN 1092-1/DN200/PN10/21/B
 3) bei diesen Baugrößen sind die Motorfüße 20 mm zu unterbauen
 3) the motor feet of these sizes are to be underpinned by 20 mm thick shims
 3) Il faut appuyer les pieds de moteur de ces tailles de construction avec des feuillets de 20 mm
 3) Con queste grandezze sotto i piedi del motore si devono sistemare degli spessori da 20 mm
 3) Bij deze grootten dienen de motorvoeten 20 mm opgevuld te worden
 4) Δ h₁ ≥ h₄
 5) Flansche DN₁ 65 / DN₂ 65 4 Loch
 5) Flanges DN₁ 65 / DN₂ 65 4 hole
 5) Brides DN₁ 65 / DN₂ 65 4 trous
 5) Bidas DN₁ 65 / DN₂ 65 4 taladro
 5) Flens DN₁ 65 / DN₂ 65 vier gaten

Etabloc BN, SN, CN 50-315/... bis 65-250/..., n = 1450 1/min, n = 1750 1/min

ohne Motorfuß (bis Motorbaugröße 112 = 4 kW)
 mit Motorfuß (ab Motorbaugröße 132 = 5,5 kW)
 without motor foot (up to motor size 112 = 4 kW)
 with motor foot (motor size 132 = 5,5 kW and above)
 sans pied de moteur (jusqu'à taille de moteur 112 = 4 kW)

avec pied de moteur (à partir de la taille de moteur 132 = 5,5 kW)
 senza piede di fusione (fino alla grandezza del motore 112 = 4 kW)
 con piede di fusione (a partire della grandezza del motore 132 = 5,5 kW)
 zonder motorvoet (tot motorgrootte 112 = 4 kW)
 met motorvoet (vanaf motorgrootte 132 = 5,5 kW)

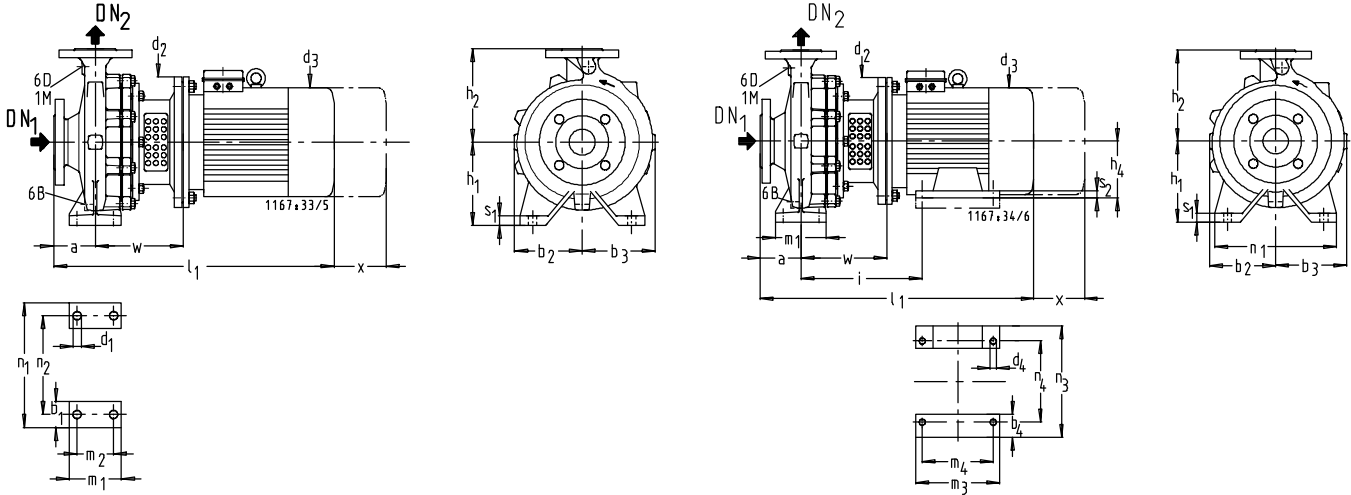

		Etabloc G, M Etabloc GN, MN, BN		Etabloc SN, CN	
		DN ₂ 32 - DN ₂ 80	DN ₂ 100	DN ₂ 32 - DN ₂ 80	DN ₂ 100 - DN ₂ 150
1 M	Druckmessgerät-Anschluss / Pressure gauge connection / Indicateur de pression / Manomètre / Manometro / Manometer	Rc 3/8 1)	Rc 1/2 1)	G 3/8 1)	G 1/2 1)
6 B	Förderflüssigkeit-Entleerung / Casing drain / Vidange du liquide pompé / Scarico del liquido convogliato / Vloeistof- aftap	Rc 3/8 1)	Rc 1/2 1)	G 3/8 1)	G 1/2 1)
6 D	Förderflüssigkeit-Auffüllen und Entlüften / Filling and venting of medium handled / Remplissage et purge d'air du liquide pompé / Riempimento del liquido convogliato spurgo dell'aria / Vloeistof vullen en ontluften	Rc 3/8 1)	Rc 1/2 1)	G 3/8 1)	G 1/2 1)

Etabloc BN, SN, CN	M	n = 1450	n = 1750	Toleranz der Anschlussmaße nach EN 735																											
				DN ₁ 2)	DN ₂ 2)	a	b ₁	b ₂	b ₃	b ₄	d ₁	d ₂	d ₃	d ₄	h ₁	h ₂	h ₄	i	l ₁	m ₁	m ₂	m ₃	m ₄	n ₁	n ₂	n ₃	n ₄	s ₁	s ₂	w	x
50-315/304	100L	x		65 ⁵⁾	50	125	65	200	216		14	250	213		225	280			697	125	95			345	280			18		190	100
50-315/404	112M	x		65 ⁵⁾	50	125	65	200	216		14	250	234		225	280			686	125	95			345	280			18		190	100
50-315/554 ^{3/4)}	132S	x	x	65 ⁵⁾	50	125	65	200	216	55	14	300	266	12	225	280	132	302	751	125	95	220	140	345	280	270	216	18	15	213	100
50-315/754 ^{3/4)}	132M	x	x	65 ⁵⁾	50	125	65	200	216	59	14	300	298	12	225	280	132	302	779	125	95	240	178	345	280	270	216	18	15	213	100
50-315/1104 ^{3/4)}	160M	x		65 ⁵⁾	50	125	65	200	216	70	14	350	325	15	225	280	160	354	917	125	95	300	210	345	280	320	254	18	21	246	100
50-315/1504 ^{3/4)}	160L	x	x	65 ⁵⁾	50	125	65	200	216	70	14	350	325	15	225	280	160	354	923	125	95	314	254	345	280	320	254	18	21	246	100
65-125/054	80	x		80	65 ⁵⁾	100	65	120	148		14	200	162		160	180			511	125	95			280	212			18		156	100
65-125/074	80	x	x	80	65 ⁵⁾	100	65	120	148		14	200	162		160	180			511	125	95			280	212			18		156	100
65-125/114	90S	x	x	80	65 ⁵⁾	100	65	120	148		14	200	190		160	180			538	125	95			280	212			18		156	100
65-125/154	90L	x	x	80	65 ⁵⁾	100	65	120	148		14	200	190		160	180			564	125	95			280	212			18		156	100
65-125/224	100L	x	x	80	65 ⁵⁾	100	65	120	148		14	250	213		160	180			617	125	95			280	212			18		170	100
65-160/114	90S	x		80	65 ⁵⁾	100	65	130	158		14	200	190		160	200			538	125	95			280	212			18		156	100
65-160/154	90L	x	x	80	65 ⁵⁾	100	65	130	158		14	200	190		160	200			564	125	95			280	212			18		156	100
65-160/224	100L	x	x	80	65 ⁵⁾	100	65	130	158		14	250	213		160	200			617	125	95			280	212			18		170	100
65-160/304	100L	x	x	80	65 ⁵⁾	100	65	130	158		14	250	213		160	200			652	125	95			280	212			18		170	100
65-160/404	112M	x	x	80	65 ⁵⁾	100	65	130	158		14	250	234		160	200			641	125	95			280	212			18		170	100
65-200/224	100L	x		80	65 ⁵⁾	100	65	154	177		14	250	213		180	225			617	125	95			320	250			18		170	140
65-200/304	100L	x		80	65 ⁵⁾	100	65	154	177		14	250	213		180	225			652	125	95			320	250			18		170	140
65-200/404	112M	x	x	80	65 ⁵⁾	100	65	154	177		14	250	234		180	225			641	125	95			320	250			18		170	140
65-200/554 ^{3/4)}	132S	x	x	80	65 ⁵⁾	100	65	154	177	55	14	300	266	12	180	225	132	282	706	125	95	220	140	320	250	270	216	18	15	193	140
65-200/754 ^{3/4)}	132M	x	x	80	65 ⁵⁾	100	65	154	177	59	14	300	298	12	180	225	132	282	734	125	95	240	178	320	250	270	216	18	15	193	140
65-250/304	100L	x		80	65 ⁵⁾	100	80	180	200		18	250	213		200	250			672	160	120			360	280			20		190	140
65-250/404	112M	x		80	65 ⁵⁾	100	80	180	200		18	250	234		200	250			661	160	120			360	280			20		190	140
65-250/554 ^{3/4)}	132S	x	x	80	65 ⁵⁾	100	80	180	200	55	18	300	266	12	200	250	132	302	726	160	120	220	140	360	280	270	216	20	15	213	140
65-250/754 ^{3/4)}	132M	x	x	80	65 ⁵⁾	100	80	180	200	59	18	300	298	12	200	250	132	302	754	160	120	240	178	360	280	270	216	20	15	213	140
65-250/1104 ^{3/4)}	160M	x		80	65 ⁵⁾	100	80	180	200	70	18	350	325	15	200	250	160	354	892	160	120	300	210	360	280	320	254	20	21	246	140

- 1) Rc = ISO 7/1; G = ISO 228/1
- 2) Etabloc BN: DN=ISO 7005-3/DN.../PN10/21; Etabloc SN: DN=EN 1092-2/DN.../PN16/21/JS1025/B; Etabloc CN: DN=EN 1092-1/DN.../PN16/21/B / DN200=EN 1092-1/DN200/PN10/21/B
- 3) bei diesen Baugrößen sind die Motorfüße 20 mm zu unterbauen
 3) the motor feet of these sizes are to be underpinned by 20 mm thick shims
 3) il faut appuyer les pieds de moteur de ces tailles de construction avec des feuillets de 20 mm
 3) Con queste grandezze sotto i piedi del motore si devono sistemare degli spessori di 20 mm/5)
 3) Bij deze grootten dienen de motorvoeten 20 mm opgevuld te worden
- 4) $\Delta h_1 \geq h_4$
- 5) Flansche DN₁ 65 / DN₂ 65 4 Loch
 5) Flanges DN₁ 65 / DN₂ 65 4-hole
 5) Brides DN₁ 65 / DN₂ 65 4 trous
 5) Bidas DN₁ 65 / DN₂ 65 4 taladro
 5) Flens DN₁ 65 / DN₂ 65 vier gaten

Etabloc BN, SN, CN 65-315/... bis 80-125/..., n = 1450 1/min, n = 1750 1/min

ohne Motorfuß (bis Motorbaugröße 112 = 4 kW)
 mit Motorfuß (ab Motorbaugröße 132 = 5,5 kW)
 without motor foot (up to motor size 112 = 4 kW)
 with motor foot (motor size 132 = 5,5 kW and above)
 sans pied de moteur (jusqu'à taille de moteur 112 = 4 kW)

avec pied de moteur (à partir de la taille de moteur 132 = 5,5 kW)
 senza piede di fusione (fino alla grandezza del motore 112 = 4 kW)
 con piede di fusione (a partire della grandezza del motore 132 = 5,5 kW)
 zonder motorvoet (tot motorgroote 112 = 4 kW)
 met motorvoet (vanaf motorgroote 132 = 5,5 kW)

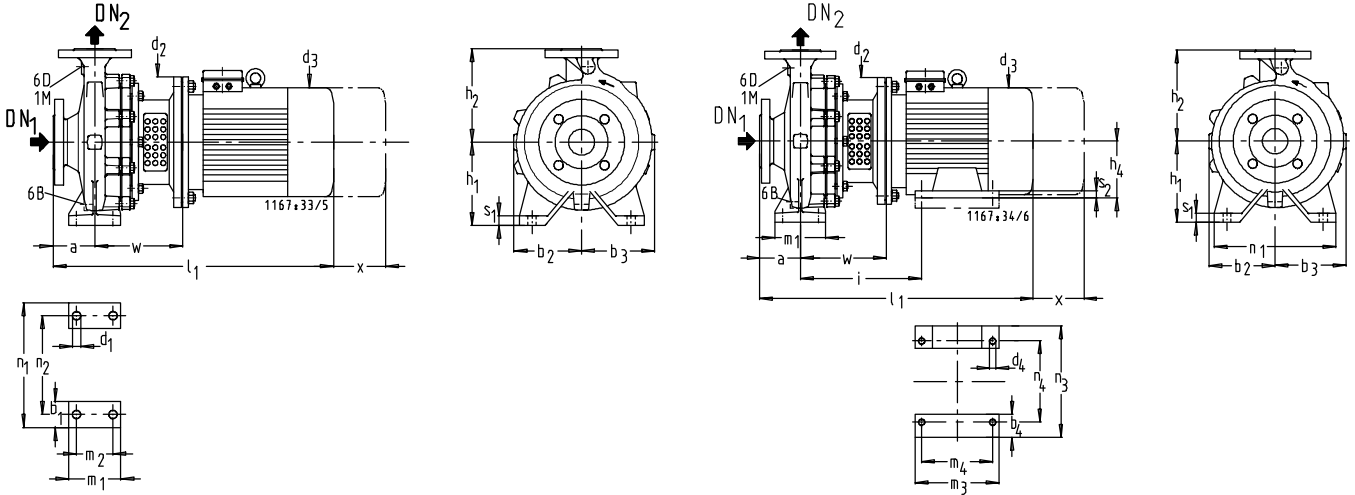

		Etabloc G, M Etabloc GN, MN, BN		Etabloc SN, CN			
		DN ₂ 32 - DN ₂ 80	DN ₂ 100	DN ₂ 32 - DN ₂ 80	DN ₂ 100 - DN ₂ 150		
1 M	Druckmessgerät-Anschluss / Pressure gauge connection / Indicateur de pression / Manomètre / Manometro / Manometer	Rc 3/8 ¹⁾	Rc 1/2 ¹⁾	G 3/8 ¹⁾	G 1/2 ¹⁾		
6 B	Förderflüssigkeit-Entleerung / Casing drain / Vidange du liquide pompé / Scarico del liquido convogliato / Vloeistof- aftap	Rc 3/8 ¹⁾	Rc 1/2 ¹⁾	G 3/8 ¹⁾	G 1/2 ¹⁾		
6 D	Förderflüssigkeit-Auffüllen und Entlüften / Filling and venting of medium handled / Remplissage et purge d'air du liquide pompé / Riempimento del liquido convogliato spurgo dell'aria / Vloeistof vullen en ontluchten	Rc 3/8 ¹⁾	Rc 1/2 ¹⁾	G 3/8 ¹⁾	G 1/2 ¹⁾		

Etabloc BN, SN, CN	M	n = 1450	n = 1750	Toleranz der Anschlussmaße nach EN 735																											
				DN ₁ 2)	DN ₂ 2)	a	b ₁ ≈	b ₂ ≈	b ₃ ≈	b ₄ ≈	d ₁	d ₂	d ₃	d ₄	h ₁	h ₂	h ₄	i	l ₁ ≈	m ₁	m ₂	m ₃	m ₄	n ₁	n ₂	n ₃	n ₄	s ₁	s ₂	w	x
65-315/554 ³⁾⁴⁾	132S	x		80	65 ⁵⁾	125	80	208	229	55	18	300	266	12	225	280	132	302	751	160	120	220	140	400	315	270	216	20	15	213	140
65-315/754 ³⁾⁴⁾	132M	x		80	65 ⁵⁾	125	80	208	229	59	18	300	298	12	225	280	132	302	779	160	120	240	178	400	315	270	216	20	15	213	140
65-315/1104 ³⁾⁴⁾	160M	x	x	80	65 ⁵⁾	125	80	208	229	70	18	350	325	15	225	280	160	354	917	160	120	300	210	400	315	320	254	20	21	246	140
65-315/1504 ³⁾⁴⁾	160L	x	x	80	65 ⁵⁾	125	80	208	229	70	18	350	325	15	225	280	160	354	923	160	120	314	254	400	315	320	254	20	21	246	140
65-315/1854 ⁴⁾	180M		x	80	65 ⁵⁾	125	80	208	229	80	18	350	370	15	225	280	180	367	981	160	120	320	241	400	315	360	279	20	23	246	140
65-315/2204 ⁴⁾	180L	x	x	80	65 ⁵⁾	125	80	208	229	80	18	350	370	15	225	280	180	367	981	160	120	358	279	400	315	360	279	20	23	246	140
80-160/154	90L	x		100	80	125	65	153	192		14	200	190		180	225			589	125	95			320	250			18		156	140
80-160/224	100L	x		100	80	125	65	153	192		14	250	213		180	225			642	125	95			320	250			18		170	140
80-160/304	100L	x		100	80	125	65	153	192		14	250	213		180	225			677	125	95			320	250			18		170	140
80-160/404	112M	x	x	100	80	125	65	153	192		14	250	234		180	225			666	125	95			320	250			18		170	140
80-160/554 ³⁾⁴⁾	132S		x	100	80	125	65	153	192	55	14	300	266	12	180	225	132	282	731	125	95	220	140	320	250	270	216	18	15	193	140
80-200/224	100L	x		100	80	125	65	161	189		14	250	213		180	250			662	125	95			345	280			18		190	140
80-200/304	100L	x		100	80	125	65	161	189		14	250	213		180	250			697	125	95			345	280			18		190	140
80-200/404	112M	x		100	80	125	65	161	189		14	250	234		180	250			686	125	95			345	280			18		190	140
80-200/554 ³⁾⁴⁾	132S	x	x	100	80	125	65	161	189	55	14	300	266	12	180	250	132	302	751	125	95	220	140	345	280	270	216	18	15	213	140
80-200/754 ³⁾⁴⁾	132M		x	100	80	125	65	161	189	59	14	300	298	12	180	250	132	302	779	125	95	240	178	345	280	270	216	18	15	213	140
80-200/1104 ³⁾⁴⁾	160M		x	100	80	125	65	161	189	70	14	350	325	15	180	250	160	354	917	125	95	300	210	345	280	320	254	18	21	246	140
80-250/404	112M	x		100	80	125	80	184	210		18	250	234		200	280			686	160	120			400	315			18		190	140
80-250/554 ³⁾⁴⁾	132S	x		100	80	125	80	184	210	55	18	300	266	12	200	280	132	302	751	160	120	220	140	400	315	270	216	18	15	213	140
80-250/754 ³⁾⁴⁾	132M	x	x	100	80	125	80	184	210	59	18	300	298	12	200	280	132	302	779	160	120	240	178	400	315	270	216	18	15	213	140
80-250/1104 ³⁾⁴⁾	160M	x	x	100	80	125	80	184	210	70	18	350	325	15	200	280	160	354	917	160	120	300	210	400	315	320	254	18	21	246	140
80-250/1504 ³⁾⁴⁾	160L		x	100	80	125	80	184	210	70	18	350	325	15	200	280	160	354	923	160	120	314	254	400	315	320	254	18	21	246	140
80-250/1854 ⁴⁾	180M		x	100	80	125	80	184	210	80	18	350	370	15	200	280	180	367	981	160	120	320	241	400	315	360	279	18	23	246	140
80-315/754 ³⁾⁴⁾	132M	x		100	80	125	80	220	244	59	18	300	298	12	250	315	132	302	779	160	120	240	178	400	315	320	216	20	15	213	140
80-315/1104 ³⁾⁴⁾	160M	x		100	80	125	80	220	244	70	18	350	325	15	250	315	160	354	917	160	120	300	210	400	315	320	254	20	21	246	140
80-315/1504 ³⁾⁴⁾	160L	x	x	100	80	125	80	220	244	70	18	350	325	15	250	315	160	354	923	160	120	314	254	400	315	320	254	20	21	246	140
80-315/1854 ⁴⁾	180M	x	x	100	80	125	80	220	244	80	18	350	370	15	250	315	180	367	981	160	120	320	241	400	315	360	279	20	23	246	140
80-315/2204 ⁴⁾	180L	x	x	100	80	125	80	220	244	80	18	350	370	15	250	315	180	367	981	160	120	358	279	400	315	360	279	20	23	246	140

- 1) Rc = ISO 7/1; G = ISO 228/1
- 2) Etabloc BN: DN=ISO 7005-3/DN.../PN10/21; Etabloc SN: DN=EN 1092-2/DN.../PN16/21/JS1025/B; Etabloc CN: DN=EN 1092-1/DN.../PN16/21/B / DN200=EN 1092-1/DN200/PN10/21/B
- 3) bei diesen Baugrößen sind die Motorfüße 20 mm zu unterbauen
 3) the motor feet of these sizes are to be underpinned by 20 mm thick shims
 3) Il faut appuyer les pieds de moteur de ces tailles de construction avec des feuillets de 20 mm
 3) Con queste grandezze sotto i piedi del motore si devono sistemare degli spessori da 20 mm
 3) Bij deze grootten dienen de motorvoeten 20 mm opgevuld te worden
- 4) h₁ ≥ h₄
- 5) Flansche DN₁ 65 / DN₂ 65 4 Loch
 5) Flanges DN₁ 65 / DN₂ 65 4-hole
 5) Brides DN₁ 65 / DN₂ 65 4 trous
 5) Bidas DN₁ 65 / DN₂ 65 4 taladro
 5) Flens DN₁ 65 / DN₂ 65 vier gaten

Etabloc BN, SN, CN 100-160/... bis 150-250/..., n = 1450 1/min, n = 1750 1/min

ohne Motorfuß (bis Motorbaugröße 112 = 4 kW)
 mit Motorfuß (ab Motorbaugröße 132 = 5,5 kW)
 without motor foot (up to motor size 112 = 4 kW)
 with motor foot (motor size 132 = 5,5 kW and above)
 sans pied de moteur (jusqu'à taille de moteur 112 = 4 kW)

avec pied de moteur (à partir de la taille de moteur 132 = 5,5 kW)
 senza piede di fusione (fino alla grandezza del motore 112 = 4 kW)
 con piede di fusione (a partire della grandezza del motore 132 = 5,5 kW)
 zonder motorvoet (tot motorgrootte 112 = 4 kW)
 met motorvoet (vanaf motorgrootte 132 = 5,5 kW)

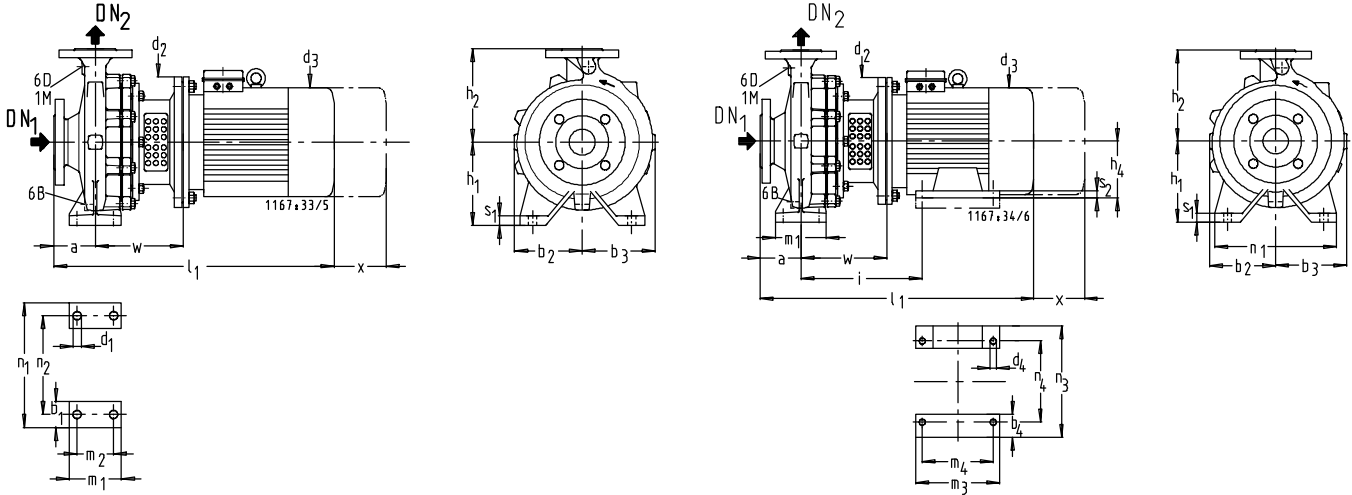

		Etabloc G, M		Etabloc SN, CN	
		Etabloc GN, MN, BN	DN ₂ 32 - DN ₂ 80	DN ₂ 100	DN ₂ 32 - DN ₂ 80
1 M	Druckmessgerät-Anschluss / Pressure gauge connection / Indicateur de pression / Manomètre / Manometro / Manometer	Rc 3/8 ¹⁾	Rc 1/2 ¹⁾	G 3/8 ¹⁾	G 1/2 ¹⁾
6 B	Förderflüssigkeit-Entleerung / Casing drain / Vidange du liquide pompé / Scarico del liquido convogliato / Vloeistof- aftap	Rc 3/8 ¹⁾	Rc 1/2 ¹⁾	G 3/8 ¹⁾	G 1/2 ¹⁾
6 D	Förderflüssigkeit-Auffüllen und Entlüften / Filling and venting of medium handled / Remplissage et purge d'air du liquide pompé / Riempimento del liquido convogliato spurgo dell'aria / Vloeistof vullen en ontluchten	Rc 3/8 ¹⁾	Rc 1/2 ¹⁾	G 3/8 ¹⁾	G 1/2 ¹⁾

Etabloc BN, SN, CN	M	n = 1450	n = 1750	Toleranz der Anschlussmaße nach EN 735																											
				DN ₁ 2)	DN ₂ 2)	a	b ₁	b ₂	b ₃	b ₄	d ₁	d ₂	d ₃	d ₄	h ₁	h ₂	h ₄	i	l ₁	m ₁	m ₂	m ₃	m ₄	n ₁	n ₂	n ₃	n ₄	s ₁	s ₂	w	x
100-160/304	100L	x		125	100	125	80	178	225		18	250	213		200	280			697	160	120			360	280			18		190	140
100-160/404	112M	x		125	100	125	80	178	225		18	300	298		200	280			686	160	120			360	280			18		190	140
100-160/554 ^{3/4)}	132S	x	x	125	100	125	80	178	225	55	18	300	266	12	200	280	132	302	751	160	120	220	140	360	280	270	216	18	15	213	140
100-160/754 ^{3/4)}	132M	x		125	100	125	80	178	225	59	18	300	298	12	200	280	132	302	779	160	120	240	178	360	280	270	216	18	15	213	140
100-200/404	112M	x		125	100	125	80	173	213		18	250	234		200	280			686	160	120			360	280			18		190	140
100-200/554 ^{3/4)}	132S	x		125	100	125	80	173	213	55	18	300	266	12	200	280	132	302	751	160	120	220	140	360	280	270	216	18	15	213	140
100-200/754 ^{3/4)}	132M	x	x	125	100	125	80	173	213	59	18	300	298	12	200	280	132	302	779	160	120	240	178	360	280	270	216	18	15	213	140
100-200/1104 ^{3/4)}	160M	x		125	100	125	80	173	213	70	18	350	325	15	200	280	160	354	917	160	120	300	210	360	280	320	254	18	21	246	140
100-200/1504 ^{3/4)}	160L	x		125	100	125	80	173	213	70	18	350	325	15	200	280	160	354	923	160	120	314	254	360	280	320	254	18	21	246	140
100-250/754 ^{3/4)}	132M	x		125	100	140	80	190	220	59	18	300	298	12	225	280	132	302	779	160	120	240	178	400	315	270	216	18	15	213	140
100-250/1104 ^{3/4)}	160M	x	x	125	100	140	80	190	220	70	18	350	325	15	225	280	160	354	917	160	120	300	210	400	315	320	254	18	21	246	140
100-250/1504 ^{3/4)}	160L	x	x	125	100	140	80	190	220	70	18	350	325	15	225	280	160	354	923	160	120	314	254	400	315	320	254	18	21	246	140
100-250/1854 ⁴⁾	180M	x		125	100	140	80	190	220	80	18	350	370	15	225	280	180	367	996	160	120	320	241	400	315	360	279	18	23	246	140
100-250/2204 ⁴⁾	180L	x		125	100	140	80	190	220	80	18	350	370	15	225	280	180	367	932	160	120	358	279	400	315	360	279	18	23	246	140
100-315/1504 ^{3/4)}	160L	x		125	100	140	80	225	255	70	18	350	325	15	250	315	160	354	938	160	120	314	254	400	315	320	254	18	21	246	140
100-315/1854 ⁴⁾	180M	x	x	125	100	140	80	225	255	80	18	350	370	15	250	315	180	367	996	160	120	320	241	400	315	360	279	18	23	246	140
100-315/2204 ⁴⁾	180L	x	x	125	100	140	80	225	255	80	18	350	370	15	250	315	180	367	996	160	120	358	279	400	315	360	279	18	23	246	140
125-200/754 ^{3/4)}	132M	x		150	125	140	80	195	244	59	18	300	298	12	250	315	132	302	794	160	120	240	178	400	315	270	216	20	15	213	140
125-200/1104 ^{3/4)}	160M	x	x	150	125	140	80	195	244	70	18	350	325	15	250	315	160	354	932	160	120	300	210	400	315	320	254	20	21	246	140
125-200/1504 ^{3/4)}	160L	x	x	150	125	140	80	195	244	70	18	350	325	15	250	315	160	354	938	160	120	314	254	400	315	320	254	20	21	246	140
125-200/1854 ⁴⁾	180M	x		150	125	140	80	195	244	80	18	350	370	15	250	315	180	367	996	160	120	320	241	400	315	360	279	20	23	246	140
125-200/2204 ⁴⁾	180L	x		150	125	140	80	195	244	80	18	350	370	15	250	315	180	367	996	160	120	358	279	400	315	360	279	20	23	246	140
125-250/1104 ^{3/4)}	160M	x		150	125	140	80	226	275	70	18	350	325	15	250	315	160	354	932	160	120	300	210	400	315	320	254	20	21	246	140
125-250/1504 ^{3/4)}	160L	x	x	150	125	140	80	226	275	70	18	350	325	15	250	315	160	354	938	160	120	314	254	400	315	320	254	20	21	246	140
125-250/1854 ⁴⁾	180M	x	x	150	125	140	80	226	275	80	18	350	370	15	250	315	180	367	996	160	120	320	241	400	315	360	279	20	23	246	140
125-250/2204 ⁴⁾	180L	x	x	150	125	140	80	226	275	80	18	350	370	15	250	315	180	367	996	160	120	358	279	400	315	360	279	20	23	246	140
150-200/754 ^{3/4)}	132M	x		200	150	160	100	238	315	59	23	300	298	12	280	400	132	302	814	200	150	240	178	550	450	270	216	20	15	213	140
150-200/1104 ^{3/4)}	160M	x		200	150	160	100	238	315	70	23	350	325	15	280	400	160	354	952	200	150	300	210	550	450	320	254	20	21	246	140
150-200/1504 ^{3/4)}	160L	x	x	200	150	160	100	238	315	70	23	350	325	15	280	400	160	354	958	200	150	314	254	550	450	320	254	20	21	246	140
150-200/1854 ⁴⁾	180M	x		200	150	160	100	238	315	80	23	350	370	15	280	400	180	367	1016	200	150	320	241	550	450	360	279	20	23	246	140
150-200/2204 ⁴⁾	180L	x		200	150	160	100	238	315	80	23	350	370	15	280	400	180	367	1016	200	150	358	279	550	450	360	279	20	23	246	140
150-250/1504 ^{3/4)}	160L	x		200	150	160	100	228	298	70	23	350	325	15	280	400	160	354	958	200	150	314	254	500	400	320	254	20	21	246	140
150-250/1854 ⁴⁾	180M	x		200	150	160	100	228	298	80	23	350	370	15	280	400	180	367	1016	200	150	320	241	500	400	360	279	20	23	246	140
150-250/2204 ⁴⁾	180L	x	x	200	150	160	100	228	298	80	23	350	370	15	280	400	180	367	1016	200	150	358	279	500	400	360	279	20	23	246	140

- 1) Rc = ISO 7/1; G = ISO 228/1
- 2) Etabloc BN: DN=ISO 7005-3/DN.../PN10/21; Etabloc SN: DN=EN 1092-2/DN.../PN16/21/SJ1025/B; Etabloc CN: DN=EN 1092-1/DN.../PN16/21/B / DN200=EN 1092-1/DN200/PN10/21/B
- 3) bei diesen Baugrößen sind die Motorfüße 20 mm zu unterbauen
- 3) the motor feet of these sizes are to be underpinned by 20 mm thick shims
- 3) Il faut appuyer les pieds de moteur de ces tailles de construction avec des feuillets de 20 mm
- 3) Con queste grandezze sotto i piedi del motore si devono sistemare degli spessori da 20 mm5)
- 3) Bij deze grootten dienen de motorvoeten 20 mm opgevuuld te worden
- 4) h₁ ≥ h₄
- 5) Flansche DN₁ 65 / DN₂ 65 4 Loch
- 5) Flanges DN₁ 65 / DN₂ 4-hole
- 5) Brides DN₁ 65 / DN₂ 65 4 trous
- 5) Bridas DN₁ 65 / DN₂ 65 4 taladro
- 5) Flens DN₁ 65 / DN₂ 65 vier gaten

Etabloc GN, MN ≥ 30 kW, n = 2900 1/min, n = 3500 1/min

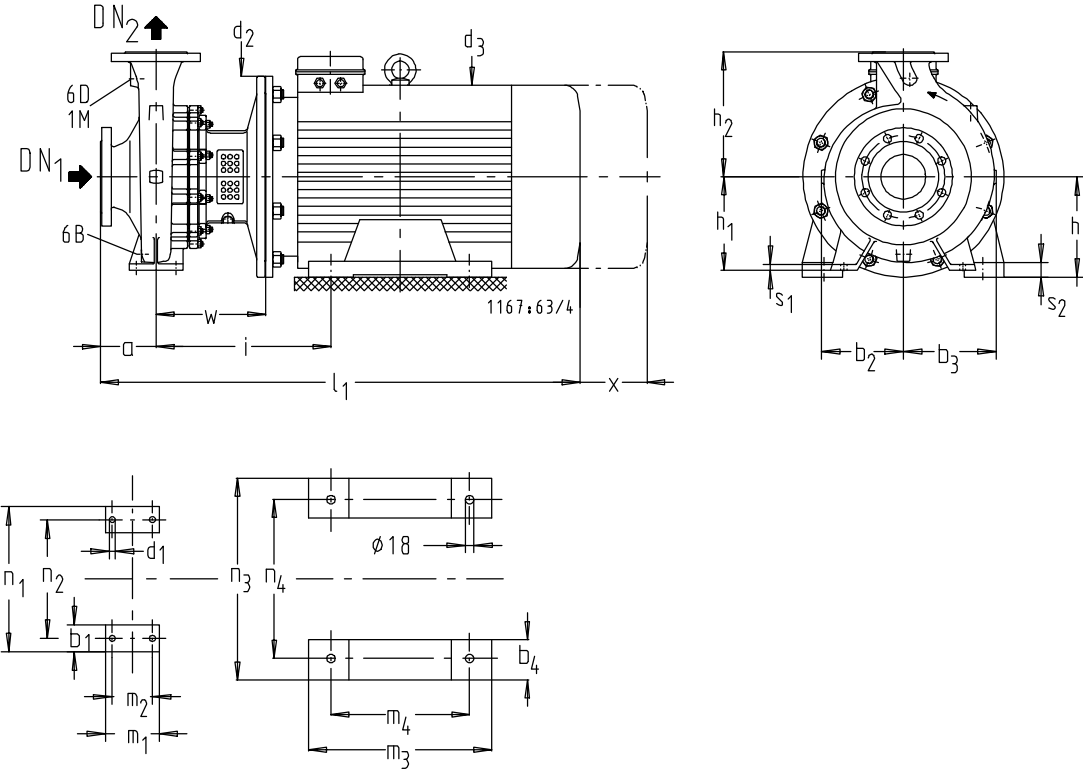

		Etabloc G, M Etabloc GN, MN, BN		Etabloc SN, CN			
		DN ₂ 32 - DN ₂ 80	DN ₂ 100	DN ₂ 32 - DN ₂ 80	DN ₂ 100 - DN ₂ 150		
1 M	Druckmessgerät-Anschluss / Pressure gauge connection / Indicateur de pression / Manomètre / Manometro / Manometer	Rc 3/8 ¹⁾	Rc 1/2 ¹⁾	G 3/8 ¹⁾	G 1/2 ¹⁾		
6 B	Förderflüssigkeit-Entleerung / Casing drain / Vidange du liquide pompé / Scarico del liquido convogliato / Vloeistof- aftap	Rc 3/8 ¹⁾	Rc 1/2 ¹⁾	G 3/8 ¹⁾	G 1/2 ¹⁾		
6 D	Förderflüssigkeit-Auffüllen und Entlüften / Filling and venting of medium handled / Remplissage et purge d'air du liquide pompé / Riempimento del liquido convogliato spurgo dell'aria / Vloeistof vullen en ontluften	Rc 3/8 ¹⁾	Rc 1/2 ¹⁾	G 3/8 ¹⁾	G 1/2 ¹⁾		

mm

Etabloc GN, MN	M	n = 2900	n = 3500	Toleranz der Anschlussmaße nach EN 735																											
				DN ₁	DN ₂	a	b ₁	b ₂	b ₃	b ₄	d ₁	d ₂	d ₃	d ₄	h ₁	h ₂	h ₄	i	l ₁	m ₁	m ₂	m ₃	m ₄	n ₁	n ₂	n ₃	n ₄	s ₁	s ₂	w	x
50-200/3002	200L		x	65	50	100	50	145	165	85	14	400	422	19	160	200	200	359	995	100	70	388	305	265	212	400	318	18	30	226	100
50-200/3702	200L		x	65	50	100	50	145	165	85	14	400	422	19	180	225	200	359	995	100	70	388	305	265	212	400	318	18	30	226	100
50-250/3002	200L	x		65	50	100	65	168	184	85	14	400	422	19	180	225	200	359	995	125	95	388	305	320	250	400	318	18	30	226	100
50-250/3702	200L	x		65	50	100	65	168	184	85	14	400	422	19	180	225	200	359	995	125	95	388	305	320	250	400	318	18	30	226	100
65-160/3002	200L		x	80	65	100	65	130	158	85	14	400	422	19	160	200	200	359	995	125	95	388	305	280	212	400	318	18	30	226	100
65-200/3002	200L		x	80	65	100	65	154	177	85	14	400	422	19	180	225	200	359	995	125	95	388	305	320	250	400	318	18	30	226	140
65-200/3702	200L		x	80	65	100	65	154	177	85	14	400	422	19	180	225	200	359	995	125	95	388	305	320	250	400	318	18	30	226	140
65-250/3002 ³⁾	200L	x		80	65	100	80	180	200	85	18	400	422	19	200	250	200	379	1015	160	120	388	305	360	280	400	318	20	30	246	140
65-250/3702 ³⁾	200L	x		80	65	100	80	180	200	85	18	400	422	19	200	250	200	379	1015	160	120	388	305	360	280	400	318	20	30	246	140
65-250/4502	225M	x		80	65	100	80	180	200	100	18	450	468	19	200	250	225	419	1125	160	120	410	311	360	280	450	356	20	35	270	140
80-160/3002	200L	x	x	100	80	125	65	153	192	85	14	400	422	19	180	225	200	359	1020	125	95	388	305	320	250	400	318	18	30	226	140
80-160/3702	200L		x	100	80	125	65	153	192	85	14	400	422	19	180	225	200	359	1020	125	95	388	305	320	250	400	318	18	30	226	140
80-200/3002	200L	x		100	80	125	65	161	189	85	14	400	422	19	180	250	200	379	1040	125	95	388	305	345	280	400	318	18	30	246	140
80-200/3702	200L	x		100	80	125	65	161	189	85	14	400	422	19	180	250	200	379	1040	125	95	388	305	345	280	400	318	18	30	246	140
80-200/4502	225M	x	x	100	80	125	65	161	189	100	14	450	468	19	180	250	225	419	1150	125	95	410	311	345	280	450	356	18	35	270	140
80-250/3002 ³⁾	200L	x		100	80	125	80	184	210	85	18	400	422	19	200	280	200	379	1040	160	120	388	305	400	315	400	318	18	30	246	140
80-250/3702 ³⁾	200L	x		100	80	125	80	184	210	85	18	400	422	19	200	280	200	379	1040	160	120	388	305	400	315	400	318	18	30	246	140
80-250/4502	225M	x		100	80	125	80	184	210	100	18	450	468	19	200	280	225	419	1150	160	120	410	311	400	315	450	356	18	35	270	140
100-160/3002 ³⁾	200L	x		125	100	125	80	178	225	85	18	400	422	19	200	280	200	379	1040	160	120	388	305	360	280	400	318	18	30	246	140
100-160/3702 ³⁾	200L	x	x	125	100	125	80	178	225	85	18	400	422	19	200	280	200	379	1040	160	120	388	305	360	280	400	318	18	30	246	140
100-160/4502	225M		x	125	100	125	80	178	225	100	18	450	468	19	200	280	225	419	1150	160	120	410	311	360	280	450	356	18	35	270	140
100-200/3002 ³⁾	200L	x		125	100	125	80	173	213	85	18	400	422	19	200	280	200	379	1040	160	120	388	305	360	280	400	318	18	30	246	140
100-200/3702 ³⁾	200L	x		125	100	125	80	173	213	85	18	400	422	19	200	280	200	379	1040	160	120	388	305	360	280	400	318	18	30	246	140
100-200/4502	225M	x		125	100	125	80	173	213	100	18	450	468	19	200	280	225	419	1150	160	120	410	311	360	280	450	356	18	35	270	140

1) Rc = ISO 7/1; G = ISO 228/1

2) DN = EN 1092-2/DN.../PN16/21/JL1040/B

3)  h₁ ≥ h₄

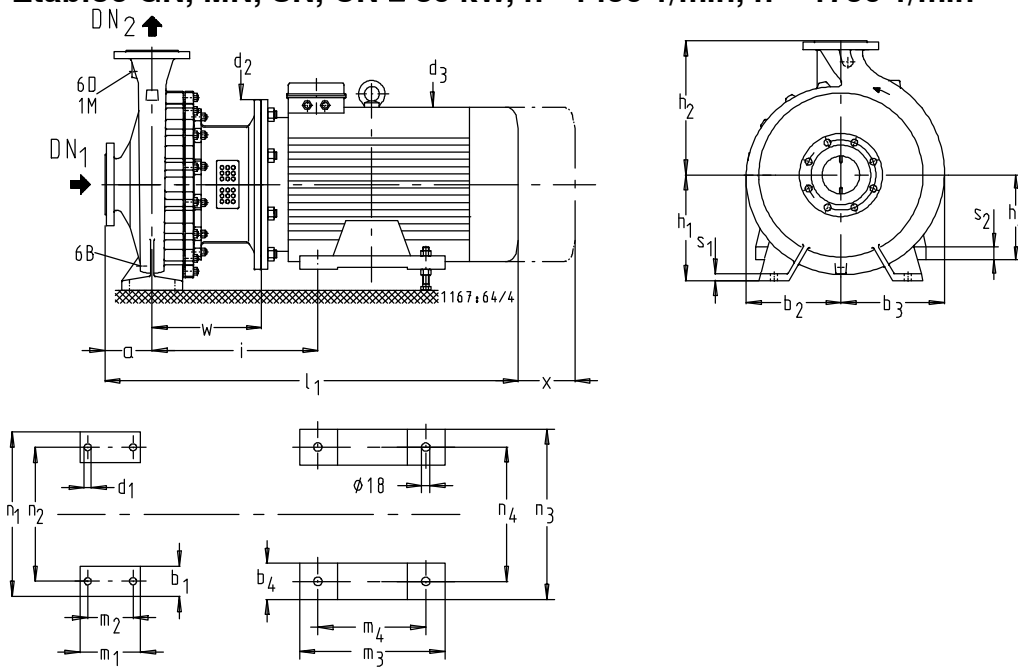
Etabloc GN, MN, SN, CN ≥ 30 kW, n = 1450 1/min, n = 1750 1/min

		Etabloc G, M Etabloc GN, MN, BN		Etabloc SN, CN	
		DN ₂ 32 - DN ₂ 80	DN ₂ 100	DN ₂ 32 - DN ₂ 80	DN ₂ 100 - DN ₂ 150
1 M	Druckmessgerät-Anschluss / Pressure gauge connection / Indicateur de pression / Manomètre / Manometro	Rc 3/8 ¹⁾	Rc 1/2 ¹⁾	G 3/8 ¹⁾	G 1/2 ¹⁾
6 B	Förderflüssigkeit-Entleerung / Casing drain / Vidange du liquide pompé / Scarico del liquido convogliato / Vloeistof- aftap	Rc 3/8 ¹⁾	Rc 1/2 ¹⁾	G 3/8 ¹⁾	G 1/2 ¹⁾
6 D	Förderflüssigkeit-Auffüllen und Entlüften / Filling and venting of medium handled / Remplissage et purge d'air du liquide pompé / Riempimento del liquido convogliato spurgo dell'aria / Vloeistof vullen en ontluiken	Rc 3/8 ¹⁾	Rc 1/2 ¹⁾	G 3/8 ¹⁾	G 1/2 ¹⁾

Etabloc GN, MN, SN, CN	Ⓜ	n = 1450	n = 1750	Toleranz der Anschlussmaße nach EN 735																											
				DN ₁ 2)	DN ₂ 2)	a	b ₁ ≈	b ₂ ≈	b ₃ ≈	b ₄ ≈	d ₁	d ₂	d ₃ =	d ₄	h ₁	h ₂	h ₄	i	l ₁ =	m ₁ ≈	m ₂	m ₃ ≈	m ₄	n ₁	n ₂	n ₃ ≈	n ₄	s ₁	s ₂	w	x
80-315/3004 ³⁾	200L	x	x	100	80	125	80	220	244	85	18	400	422	19	250	315	200	379	1040	160	120	388	305	400	315	400	318	20	30	246	140
80-315/3704 ³⁾	225S	x	x	100	80	125	80	220	244	100	18	450	460	19	250	315	225	419	1090	160	120	385	286	400	315	450	356	20	35	270	140
80-400/3004 ³⁾	200L	x	x	100	80	125	80	253	276	85	18	400	422	19	280	355	200	391	1052	160	120	388	305	435	355	400	318	20	30	258	140
80-400/3704 ³⁾	225S	x	x	100	80	125	80	253	276	100	18	450	460	19	280	355	225	437	1108	160	120	385	286	435	355	450	356	20	35	288	140
80-400/4504 ³⁾	225M	x	x	100	80	125	80	253	276	100	18	450	468	19	280	355	225	437	1138	160	120	410	311	435	355	450	356	20	35	288	140
100-315/3004 ³⁾	200L	x	x	125	100	140	80	225	255	85	18	400	422	19	250	315	200	379	1055	160	120	388	305	400	315	400	318	18	30	246	140
100-315/3704 ³⁾	225S	x	x	125	100	140	80	225	255	100	18	450	460	19	250	315	225	419	1105	160	120	385	286	400	315	450	356	18	35	270	140
100-315/4504 ³⁾	225M	x	x	125	100	140	80	225	255	100	18	450	468	19	250	315	225	419	1135	160	120	410	311	400	315	450	356	18	35	270	140
100-400/3004 ³⁾	200L	x	x	125	100	140	100	253	280	85	23	400	422	19	280	355	200	391	1067	200	150	388	305	500	400	400	318	20	30	258	140
100-400/3704 ³⁾	225S	x	x	125	100	140	100	253	280	100	23	450	460	19	280	355	225	437	1123	200	150	385	286	500	400	450	356	20	35	288	140
100-400/4504 ³⁾	225M	x	x	125	100	140	100	253	280	100	23	450	468	19	280	355	225	437	1153	200	150	410	311	500	400	450	356	20	35	288	140
125-250/3004 ³⁾	200L	x	x	150	125	140	80	226	275	85	18	400	422	19	250	315	200	379	1055	160	120	388	305	400	315	400	318	20	30	246	140
125-250/3704 ³⁾	225S	x	x	150	125	140	80	226	275	100	18	450	460	19	250	315	225	419	1105	160	120	385	286	400	315	450	356	20	35	270	140
125-315/3004 ³⁾	200L	x	x	150	125	140	100	238	278	85	23	400	422	19	280	355	200	391	1067	200	150	388	305	500	400	400	318	20	30	258	140
125-315/3704 ³⁾	225S	x	x	150	125	140	100	238	278	100	23	450	460	19	280	355	225	437	1123	200	150	385	286	500	400	450	356	20	35	288	140
125-315/4504 ³⁾	225M	x	x	150	125	140	100	238	278	100	23	450	468	19	280	355	225	437	1153	200	150	410	311	500	400	450	356	20	35	288	140
125-400/3004 ³⁾	200L	x	x	150	125	140	100	275	306	85	23	400	422	19	315	400	200	391	1067	200	150	388	305	500	400	400	318	20	30	258	140
125-400/3704 ³⁾	225S	x	x	150	125	140	100	275	306	100	23	450	460	19	315	400	225	437	1123	200	150	385	286	500	400	450	356	20	35	288	140
125-400/4504 ³⁾	225M	x	x	150	125	140	100	275	306	100	23	450	468	19	315	400	225	437	1153	200	150	410	311	500	400	450	356	20	35	288	140
150-250/3004 ³⁾	200L	x	x	200	150	160	100	228	298	85	23	400	422	19	280	400	200	379	1075	200	150	388	305	500	400	400	318	20	30	246	140
150-250/3704 ³⁾	225S	x	x	200	150	160	100	228	298	100	23	450	460	19	280	400	225	419	1125	200	150	385	286	500	400	450	356	20	35	270	140
150-250/4504 ³⁾	225M	x	x	200	150	160	100	228	298	100	23	450	468	19	280	400	225	419	1155	200	150	410	311	500	400	450	356	20	35	270	140
150-315/3004 ³⁾	200L	x	x	200	150	160	100	255	303	85	23	400	422	19	280	400	200	391	1087	200	150	388	305	550	450	400	318	20	30	258	140
150-315/3704 ³⁾	225S	x	x	200	150	160	100	255	303	100	23	450	460	19	280	400	225	437	1143	200	150	385	286	550	450	450	356	20	35	288	140
150-315/4504 ³⁾	225M	x	x	200	150	160	100	255	303	100	23	450	468	19	280	400	225	437	1173	200	150	410	311	550	450	450	356	20	35	288	140

1) Rc = ISO 7/1; G = ISO 228/1

2)

	DN 80, 100 DN 125, 150	DN 200
Etabloc GN, MN	EN 1092-2/DN.../PN 16/21/JL1040/B	EN 1092-2/DN.../PN 10/21/JL1040/B
Etabloc SN	EN 1092-2/DN.../PN 16/21/JS1025/B	
Etabloc CN	N 1092-1/DN.../PN 16/21/B	EN 1092-1/DN.../PN 10/21/B

 3) h₁ ≥ h₄

Voorraad reservedelen
Uitwisselbaarheid van pompdelen tussen Etabloc en Etanorm en pompdelen onderling

Etabloc	Lagerstoelgrootte	Onderdeelbenaming													Waaier	Mechanische asafdichting	Slijtring zuigzijde	Slijtring perszijde	Asbus
		Pomphuis	Drukdeksel	As 1)															
		Onderdeelnr.																	
102	103	71	80	90	100 112	132	160	180	200	225	225	230	433	502.1	502.2	523			
25-20/...	25	○	○										○	○	x	x	x		
32-23/...		○	x										○	○	x	x	x		
32-125.1/...		○	1	1	2	3	4	5	□	□	□	▲	▲	○	1	1	x	1	
32-160.1/...		○	1	1	2	3	4	5	□	□	□	▲	▲	1	1	1	3	1	
32-200.1/...		○	2	□	2	3	4	5	6	□	□	▲	▲	2	1	1	3	1	
32-250.1/...		○	3	□	2	3	4	5	6	□	□	▲	▲	3	1	1	4	1	
32-125/...		○	1	1	2	3	4	5	□	□	□	▲	▲	○	1	1	x	1	
32-160/...		○	1	□	2	3	4	5	□	□	□	▲	▲	1	1	1	3	1	
32-200/...		○	2	□	2	3	4	5	6	□	□	▲	▲	2	1	1	3	1	
32-250/...		○	3	□	□	3	4	5	6	□	□	▲	▲	3	1	1	4	1	
40-125/...		○	1	1	2	3	4	5	6	□	□	▲	▲	○	1	2	x	1	
40-160/...		○	1	□	2	3	4	5	6	□	□	▲	▲	○	1	2	3	1	
40-200/...		○	2	□	2	3	4	5	6	7	□	▲	▲	○	1	○	3	1	
40-250/...		○	3	□	□	3	4	5	6	7	□	▲	▲	○	1	2	4	1	
40-315/...		35	○	○	▲	▲	▲	8	9	10	□	□	▲	□	○	2	2	12	2
50-125/...	25	○	1	□	2	3	4	5	6	□	□	▲	▲	○	1	3	3	1	
50-160/...		○	1	□	2	3	4	5	6	7	□	▲	▲	○	1	3	3	1	
50-200/...		○	2	□	□	3	4	5	6	7	12	▲	▲	○	1	3	3	2	
50-250/...		○	3	□	□	□	4	5	6	7	12	▲	▲	○	1	3	4	1	
50-315/...	35	○	4	▲	▲	▲	8	9	10	□	▲	▲	□	○	2	5	10	2	
65-125/...	25	○	1	□	2	3	4	5	6	□	□	▲	▲	○	1	5	3	1	
65-160/...		○	5	□	□	3	4	5	6	7	12	▲	▲	○	1	5	9	1	
65-200/...		○	○	□	□	□	4	5	6	7	12	▲	▲	○	1	5	9	1	
65-250/...	35	○	○	▲	▲	▲	8	9	10	11	13	15	14	○	2	9	12	2	
65-315/...		○	4	▲	▲	▲	□	9	10	11	□	□	□	○	2	9	10	2	
80-160/...		25	○	5	□	□	3	4	□	6	7	12	▲	▲	○	1	6	9	1
80-200/...	35	○	6	▲	▲	▲	8	9	□	□	13	15	□	○	2	6	10	2	
80-250/...		○	7	▲	▲	▲	8	9	10	11	13	15	□	○	2	6	10	2	
80-315/...		○	4	▲	▲	▲	□	9	10	11	13	□	14	○	2	6	10	2	
80-400/...	55	○	10	▲	▲	▲	▲	▲	▲	▲	16	▲	17	○	3	○	○	3	
100-160/...	35	○	6	▲	▲	▲	8	9	10	11	13	15	▲	○	2	7	10	2	
100-200/...		○	6	▲	▲	▲	8	9	10	11	13	15	▲	○	2	7	10	2	
100-250/...		○	7	▲	▲	▲	□	9	10	11	□	▲	□	○	2	7	10	2	
100-315/...		○	4	▲	▲	▲	□	□	10	11	13	▲	14	○	2	7	10	2	
100-400/...	55	○	10	▲	▲	▲	▲	▲	▲	▲	16	▲	17	○	3	7	8	3	
125-200/...	35	○	8	▲	▲	▲	□	9	10	11	□	▲	□	○	2	8	11	2	
125-250/...		○	9	▲	▲	▲	□	□	10	11	13	▲	□	○	2	8	11	2	
125-315/...	55	○	11	▲	▲	▲	▲	▲	▲	▲	16	▲	17	○	3	8	8	3	
125-400/...		○	10	▲	▲	▲	▲	▲	▲	▲	▲	16	▲	17	○	3	8	8	3
150-200/...	35	○	8	▲	▲	▲	□	9	10	11	□	▲	□	○	2	○	11	2	
150-250/...		○	9	▲	▲	▲	□	□	10	11	13	▲	14	○	2	14	13	2	
150-315/...		55	○	11	▲	▲	▲	▲	▲	▲	▲	16	▲	17	○	3	14	8	3

M	Aandrijflantaarn 341		
	Lagerstoelgrootte		
	25	35	55
71	○	—	—
80	1	—	—
90	1	—	—
100	2	4	—
112	2	4	—
132	○	○	—
160	3	6	—
180	3	6	—
200	7	8	10
225	—	9	11

M	Vermogen		
71	.../024, .../034		
80	.../054, .../074, .../072, .../112		
90	.../114, .../154, .../152, .../222		
100	.../224, .../304, .../302		
112	.../404, .../402		
132	.../554, .../754, .../552, .../752		
160	.../1104, .../1504, .../1102, .../1502, .../1852		
180	.../1854, .../2204, .../2202		
200	.../3004, .../3002, .../3702		
225	.../3704, .../4504, .../4502,		

1) alleen Etabloc met norm-motor

<input type="checkbox"/> 1	verticaal gelijk getal = gelijk onderdeel	<input type="checkbox"/> X	onderdeel komt niet voor	<input type="checkbox"/> ▲	deze pomp-/motorcombinatie niet mogelijk
<input type="checkbox"/> ○	verschillende onderdelen	<input type="checkbox"/> □	deze pomp-/motorcombinatie op aanvraag	<input type="checkbox"/> ■	onderdelen met Etanorm uitwisselbaar

Aanbevolen voorraad reservedelen voor tweejarig bedrijf volgens DIN 24 296

Onder-deelnr.	Onderdeelbenaming	Aantal pompen (inclusief reservepompen)						
		2	3	4	5	6 und 7	8 en 9	10 en meer
		Aantal reservedelen						
210	As ¹⁾	1	1	1	2	2	2	20 %
230	waaier (inclusief slijtring 502.2) ²⁾	1	1	1	2	2	2	20 %
230.1/.2	Waaier ³ (set)	1	1	1	2	2	2	20 %
400.1/.2	Vlakke pakking ⁴⁾ (set)	4	6	8	8	9	12	150 %
412.3	O-ring ³⁾	2	3	4	4	4	5	10 %
433	Mechanische asafdichting	1	1	2	2	2	3	25 %
502.1/.2	Slijtring ²⁾	2	2	2	3	3	4	50 %
523	Asbus	2	2	2	3	3	4	50 %
---	Vlakke pakking	4	6	8	8	9	12	150 %

1) vervalt bij Etabloc G, M

2) vervalt bij Etabloc 25-20.1/... en 32-23.1/...

3) alleen bij Etabloc 32-23.1/...

4) vervalt bij Etabloc 32-23.1/...